



ST-587 Series PTSA + Turbidity Sensors

Inline Sensors for Industrial Cooling & Process Water



Pyxis Lab® Inc.

21242 Spell Circle
Tomball, TX 77375
www.pyxis-lab.com

USER MANUAL

Table of Contents

1. Introducing the Pyxis ST-587 Series Sensor	3
1.1 Specifications	4
1.2 Unpacking the ST-587	5
1.3 Standard Accessories	5
1.4 Optional Accessories	5
2. Installation	6
2.1 ST-587 Installation.....	6
2.2 ST-587SS Installation	7
3. Wiring & Quick 4-20mA Startup	8
4. Calibration and Diagnosis with the uPyxis 2.0 Mobile App	9
4.1 Calibration and Diagnosis by uPyxis Mobile App	9
4.1.1 PTSA Calibration.....	11
4.1.2 Turbidity Calibration.....	12
4.1.3 Adjusting the 4-20mA Span	13
4.1.4 Diagnosis & Cleanliness check.....	14
4.2 Calibration and Diagnosis with the uPyxis Desktop App	15
4.2.1 PTSA Calibration.....	18
4.2.2 Turbidity Calibration.....	19
4.2.3 4-20mA Span	20
4.2.4 Diagnosis & Cleanliness check.....	21
5. Modbus RTU	21
6. Sensor Cleaning and Maintenance.....	22
7. Other Common Troubleshooting Issues	23
8. Contact Us.....	23

Warranty Information

Confidentiality

The information contained in this manual may be confidential and proprietary and is the property of Pyxis Lab, Inc. Information disclosed herein shall not be used to manufacture, construct, or otherwise reproduce the goods described. Information disclosed herein shall not be disclosed to others or made public in any manner without the express written consent of Pyxis Lab, Inc.

Standard Limited Warranty

Pyxis Lab warrants its products for defects in materials and workmanship. Pyxis Lab will, at its option, repair or replace instrument components that prove to be defective with new or remanufactured components (i.e., equivalent to new). The warranty set forth is exclusive and no other warranty, whether written or oral, is expressed or implied.

Warranty Term

The Pyxis warranty term for the ST-587 Series sensor is thirteen (13) months from original shipment from Pyxis. In no event shall the standard limited warranty coverage extend beyond thirteen (13) months from original shipment date.

Warranty Service

Damaged or dysfunctional instruments may be returned to Pyxis for repair or replacement. In some instances, replacement instruments may be available for short duration loan or lease.

Pyxis warrants that any labor services provided shall conform to the reasonable standards of technical competency and performance effective at the time of delivery. All service interventions are to be reviewed and authorized as correct and complete at the completion of the service by a customer representative, or designate. Pyxis warrants these services for 30 days after the authorization and will correct any qualifying deficiency in labor provided that the labor service deficiency is exactly related to the originating event. No other remedy, other than the provision of labor services, may be applicable.

Repair components (parts and materials), but not consumables, provided during a repair, or purchased individually, are warranted for 90 days ex-works for materials and workmanship. In no event will the incorporation of a warranted repair component into an instrument extend the whole instrument's warranty beyond its original term.

Warranty Shipping

A Repair Material Authorization (RMA) Number must be obtained from Pyxis Technical Support before any product can be returned to the factory. Pyxis will pay freight charges to ship replacement or repaired products to the customer. The customer shall pay freight charges for returning products to Pyxis. Any product returned to the factory without an RA number will be returned to the customer. To receive an RMA you can generate a request on our website at [Request Return or Repair - Pyxis Lab, Inc. \(pyxis-lab.com\)](https://www.pyxis-lab.com/Request-Return-or-Repair)

Pyxis Technical Support

Contact Pyxis Technical Support at +1 (866) 203-8397 ext 2, service@pyxis-lab.com

1. Introducing the Pyxis ST-587 Series Sensor

The Pyxis ST-587 Series inline fluorometer & turbidimeter sensor simultaneously measures the concentration of PTSA (Pyrenetetrasulfonic Acid, CAS# 59572-10-0) and Turbidity in water, utilizing both LED UV and Warm White light sources. PTSA is commonly used as a fluorescent tracer in cooling and process water treatment applications where turbidity measurement may be a key performance indicator and critical parameter to application efficacy. This unique Pyxis sensor platform is offered in both UPVC and 304-stainless steel material depending on application pressures. The SS (stainless steel) version of the sensor platform is ideally suited for high pressure water systems (>100psi / 20 Bar) while the UPVC version of the sensor platform are better suited for application pressures below (100psi / 6.9 Bar).

The ST-587 Series sensors can be connected to any device that accepts an isolated or non-isolated 4–20mA input or RS-485 Modbus input. The ST-587 Series sensor is a smart device. In addition to measuring PTSA, the ST-587 sensor has extra photo-electric components that measure the color and turbidity of the sample water. This extra feature allows automatic color and turbidity compensation to eliminate interference commonly experienced in real-world applications (as high as 150NTU) as well as in-situ sensor cleanliness diagnostic data. The ST-587 Series sensors have a short fluidic channel, are very easy to clean and are uniquely designed to overcome shortcomings associated with other fluorometers that have a distal (flat) sensor surface or a long, narrow fluidic cell. Traditional inline fluorometers are susceptible to color and turbidity interference and fouling and are difficult to properly clean and offer no cleanliness verification.

The Pyxis ST-587 Series sensors use a narrow wavelength band gallium phosphide photodiode and high temperature-tolerant and humidity-resistant optical filters. This combination greatly enhances the robustness of the probe. It can be operated under a wide range of ambient conditions without the need of humidity and temperature regulation. The performance of the ST-587 Series sensors can be stable and consistent for a long period of time. In addition, the ST-587 series sensors can be easily diagnosed, cleaned and calibrated using the MA-CR Bluetooth/USB adapter and the uPyxis® mobile or desktop application.



Figure 1 - ST-587 Sensor with ST-001 Inline Tee Assembly & ST-587SS Sensor

1.1 Specifications

Item	ST-587	ST-587SS
Part Number (P/N)	50906	58925
PTSA Range	0–500 ppb	
PTSA Resolution	0.01 ppb	
PTSA Accuracy	±1% of reading	
Turbidity Range	0–200 NTU	
Turbidity Resolution	0.1 NTU	
Turbidity Accuracy	±2% of reading	
PTSA Calibration	Single-Point or Two-Point calibration against PTSA standard solutions	
Turbidity Calibration	Single-Point or Two-Point calibration against Turbidity standard solutions	
Excitation of PTSA	365 nm	
Emission of PTSA	410 nm	
Turbidity Light Source (LED)	Warm White (EPA 180.1)	
Outputs	2x 4–20mA Analog Outputs / RS-485 Digital Output – 8Pin	
Installation	ST-001 Inline Tee (provided) ¾" FNPT Socket & Thread	¾" FNPT Threading
Cable Length	1.5 meter 8-pin Bulkhead w Adapter/ 1.5 meter 8-pin Flying Lead w Adapter	
Power Supply	22–26 VDC, ≈ 2W maximum at 20mA	
Dimension (L × Dia) ‡	6.8 × 1.44 inch (172.7 × 36.6 mm)	8.1 × 1.66 inch (206.1 × 41.5 mm)
Weight	0.37 lbs. (170 g)	2.5 lbs. (1148 g)
Material	UPVC	304 Stainless Steel
Operational Temperature	40 – 120 °F (4 °C – 49 °C)	
Storage Temperature	20 – 140 °F (-7°C – 60 °C)	
Pressure	Up to 100 psi (6.9 Bar)	Up to 290 psi (20 Bar)
Enclosure Rating	IP67	
Regulation	CE / RoHS / UKCA	

NOTE Specifications are subject to change without notice.

1.2 Unpacking the ST-587

Remove the instrument and accessories from the shipping container and inspect each item for any damage that may have occurred during shipping. Verify that all items listed on the packing slip are included. If any items are missing or damaged, please contact Pyxis Customer Service at service@pyxis-lab.com

1.3 Standard Accessories

- One **ST-587** (P/N: 50906) or **ST-587SS** (P/N: 58925) sensor with attached 1.5m bulkhead cable (8pin Adapter)
- One Tee Assembly ¾-inch FNPT Thread & Socket with O-Ring & Sensor Nut P/N: ST-001
**NOTE* ST-001 is not included with ST-587SS as the sensor is ¾-inch FNPT Stainless Steel*
- One Flying Lead Cable (1.5m / 8Pin Cable w/Adapter) P/N: MA-1.5CR
- The full instrument manual is available for download at [Support Documents - Pyxis Lab, Inc. \(pyxis-lab.com\)](http://Support Documents - Pyxis Lab, Inc. (pyxis-lab.com))
- Alternative Inline Tee's and Adapters are also available – for info contact order@pyxis-lab.com

1.4 Optional Accessories

The following optional accessories can be purchased via order@pyxis-lab.com or your preferred Pyxis Lab distributor.

Accessory Name	P/N
Pyxis Probe Cleaning Kit <i>(Includes Sensor Cleaner 500mL + Accessories)</i>	SER-01
MA-CR Bluetooth/USB Adapter <i>(Pyxis Bluetooth/USB Adapter for 8Pin Pyxis Sensors)</i>	MA-CR
PowerPACK-1 <i>(Single Chanel Auxiliary Power Supply w/Bluetooth For Pyxis Sensors)</i>	MA-BLE-1
PowerPACK-4 <i>(Four Chanel Auxiliary Power Supply w/Bluetooth For Pyxis Sensors)</i>	MA-BLE-4
MA-10CR <i>(10' Extension Cable for 8Pin Pyxis Sensors)</i>	50741
MA-50CR <i>(50' Extension Cable for 8Pin Pyxis Sensors)</i>	50743
PTSA STANDARD - 100 ppb <i>(500 mL)</i>	21001
PTSA STANDARD - 200 ppb <i>(500 mL)</i>	21000
PTSA STANDARD - 300 ppb <i>(500 mL)</i>	21003
Formazine Turbidity Calibration Standard – 100 NTU <i>(500 mL)</i>	57010

2. Installation

2.1 ST-587 Installation

The provided ST-001 Tee Assembly can be connected to a pipe system through the ¾-inch female ports, both socket and FNPT threaded adapters are provided. The tee may be installed in both horizontal or vertical water flow arrangement with sample inlet pressure less than 100psi. Isolation valves before and after the ST-001 tee assembly are suggested to allow for user adjusted flow rate as well as sensor removal for cleaning and maintenance. The ST-001 and ST-587 can be operated up to 100psi and will allow up to 8GPM of flow.

To properly install the ST-587 sensor into the ST-001 Tee Assembly, follow the steps below:

1. Insert the provided O-ring into the O-ring groove on the tee.
2. Insert the ST-587 sensor into the tee.
3. Tighten the tee nut onto the tee to form a water-tight, compression seal.

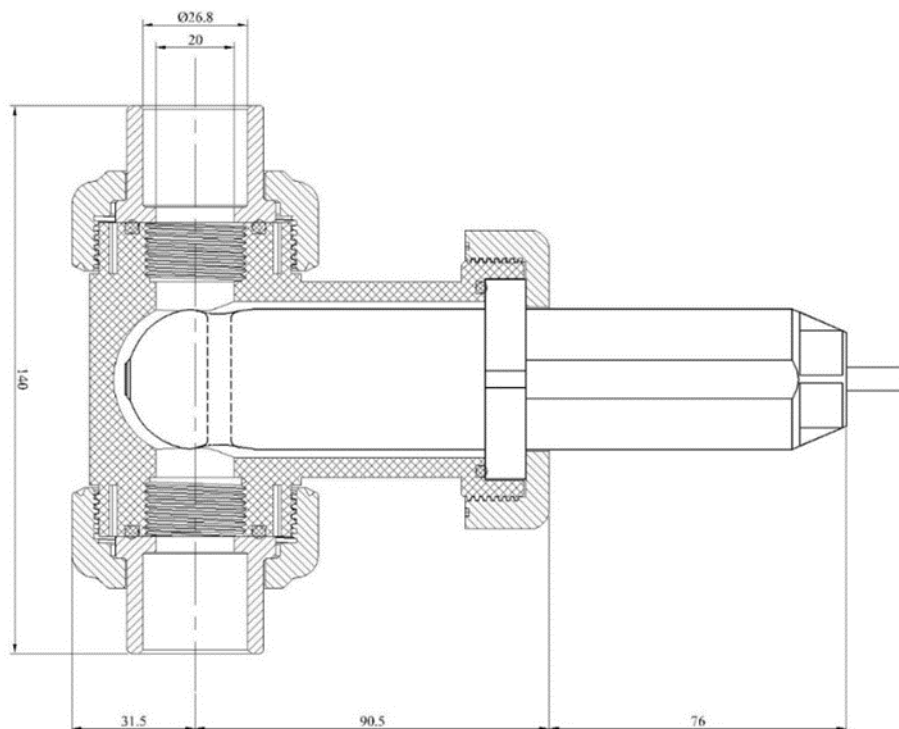

Figure 2 - Dimension of the ST-587 and the ST-001 Tee Assembly (mm)

2.2 ST-587SS Installation

The ST-587SS sensor is uniquely designed for high-pressure cooling and process water applications. The sensor has 3/4-inch female NPT threaded ports and therefore does not require a custom tee assembly. The sensor may be installed in both horizontal or vertical water flow arrangement with sample inlet pressure less than 290psi. ***NOTE*** Unions and Isolation valves before and after the ST-001 tee assembly are suggested to allow for user adjusted flow rate as well as sensor removal for cleaning and maintenance.

The sensor can be held by a 1.75-inch pipe clamp or mounted to a panel with four 1/4-inch / 28 bolts.

See Figure 3 for ST-587SS dimensions.

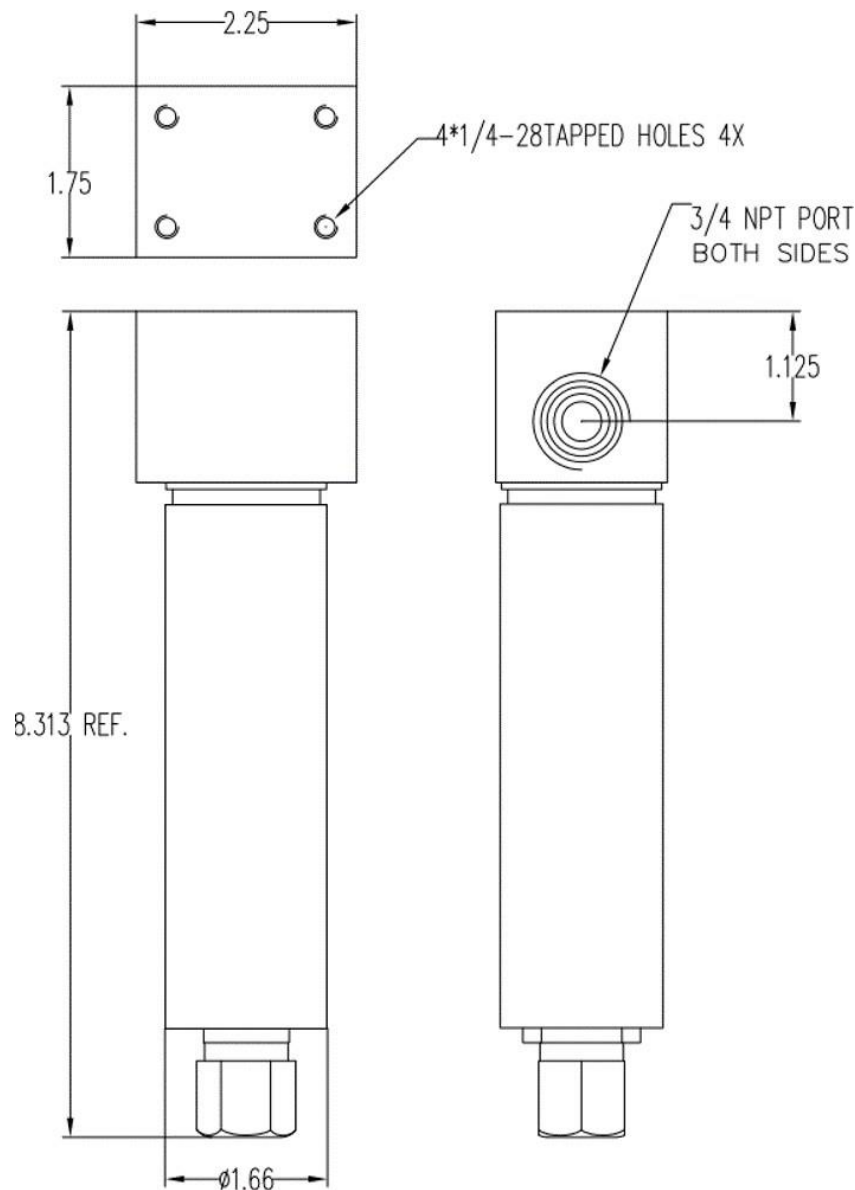

Figure 3 – Dimension of the ST-587SS (inch)

3. Wiring & Quick 4-20mA Startup

The ST-587 Series provides passive 4-20mA outputs. They should not be connected to a loop powered input. If the power ground terminal and the negative 4–20mA terminal in the controller are internally connected (non-isolated 4–20mA input), it is unnecessary to connect the 4–20mA negative wire (gray) to the 4–20mA negative terminal in the controller. If a separate DC power supply other than that from the controller is used, make sure that the output from the power supply is rated for 22–26 VDC @ 85 mA.

Follow the wiring table below to connect the ST-587 Series sensor to a controller:

Wire Color	Designation
Red	24 V +
Brown	24V Power ground
White	4-20mA+ for PTSA
Pink	4-20mA+ for Turbidity
Gray*	4–20mA -
Blue	RS-485 A
Yellow	RS-485 B
Green	RS-485 C, earth ground

* 4-20mA- and Power Ground are internally connected

ST-587 Sensor 4-20mA Scaling		
Unit of Measure	4mA Value	20mA Value
PTSA	0 ppb	500 ppb
Turbidity	0 NTU	200 NTU

***NOTE*:** *The 24V power ground and the 4-20 mA- return are internally connected. If insufficient wattage is available from the connected controller (i.e., up to combined 2W maximum at 20mA reading for both PTSA and Turbidity), Pyxis recommends the **PowerPACK Series** Auxiliary Power & Bluetooth Communication Adapters highlighted in the Optional Accessories section of this manual.*

4. Calibration and Diagnosis with the uPyxis 2.0 Mobile App

The ST-587 Series sensors are rigorously calibrated before leaving the factory. If calibration is required, users can perform a single-point calibration after confirming the sensor cleanliness with uPyxis APP while the sensor remains inline (operational) based on a handheld test result of the sample being measured. Or users may perform a two-point calibration (Zero & Slope) for PTSA and Turbidity after confirming the sensor cleanliness with the uPyxis APP in a light covered beaker using DI water and proper PTSA and Turbidity Calibration Standard Solutions. See Section 4.1.4 for Cleanliness Diagnosis Check instructions.

4.1 Calibration and Diagnosis by uPyxis Mobile App

Install the MA-CR Pyxis Bluetooth adapter (P/N: MA-CR) between the ST-587 bulkhead cable and flying lead cable connected to the display or controller, using the 8-pin adapters as shown in the following connection diagram. The power should be sourced from a 24 VDC power terminal of the display or controller. If not available, please purchase a 24VDC power supply or use the Pyxis PowerPACK Series Bluetooth adapters (See Section 1.4 Optional Accessories).



MA-CR Bluetooth Adapter

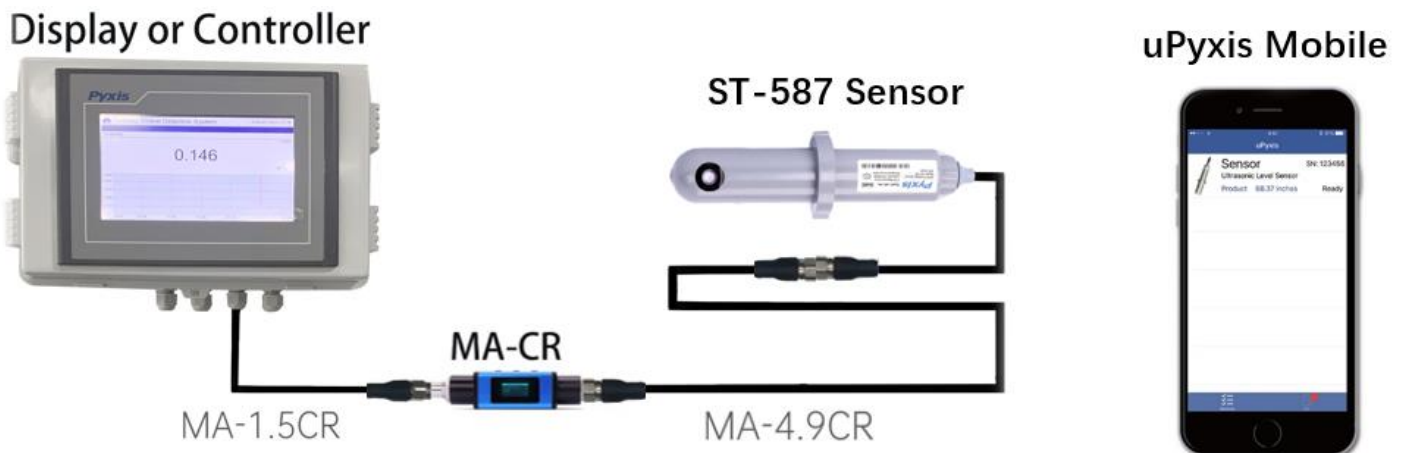

Figure 4–

Power the ST-587 Series via Display or Controller with the MA-CR Bluetooth Adapter inserted between Bulkhead & Flying Lead Cables



Download and install the **uPyxis2.0** app from **Apple Store** or **Google Play**. Turn ON the Bluetooth in the smart device being used. Please do not pair your devices Bluetooth to uPyxis, the app will do the pairing. Open the uPyxis app on the device. Click the **Scan Bluetooth** button to scan the available Pyxis Bluetooth devices. The discovered devices will be listed as shown in *Figure 5*. This may take up to one minute.

Tap the discovered ST-587 sensor to connect to the sensor. The uPyxis app will identify the sensor type if multiple Pyxis sensors are discovered in the scan.

As shown in *Figure 6*, uPyxis will default to the **Trend Chart** page after connected to the sensor via the MA-CR Bluetooth adapter. The measurement value will be displayed as a line graph to show the real-time trend.

Tap **Configuration** in the top of the app page to launch the configuration page. Five functional tabs of each are available on this page: Information, Configuration, Calibration, 4-20mA Span and Diagnosis.

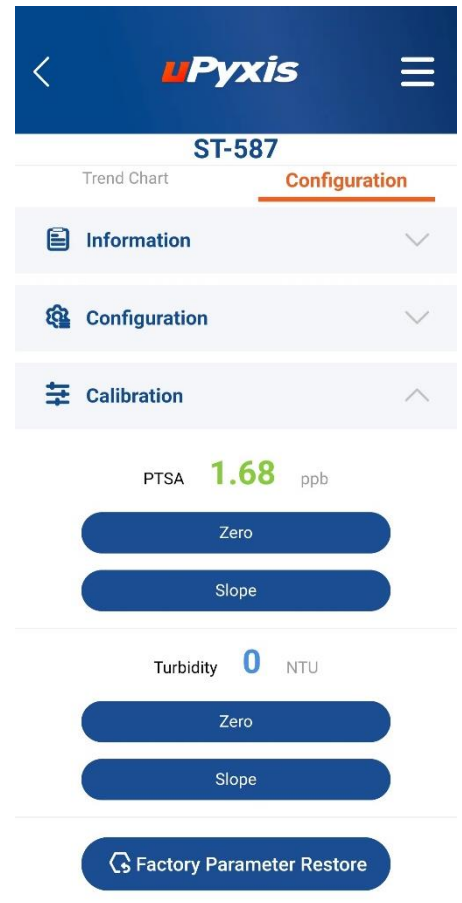

Figure 5 - ST-587 Discovered via Bluetooth

Figure 6 – Trend Chart Page

Figure 7 – Configuration Page

4.1.1 PTSA Calibration

Single Point (In-Situ) PTSA Calibration

If you have confirmed the ST-587 sensor is clean by using the Cleanliness Check Function of the Diagnostic tab within uPyxis 2.0 (see section 4.1.4), users may conduct an in-situ slope calibration of PTSA while the sensor is in operation. Users can tap **Slope CALIBRATION** and enter the handheld measured PTSA value, then hit confirm. ***NOTE*** *If the sensor is dirty, it must be removed for proper optical channel cleaning with the Pyxis Probe Cleaning Solution (P/N SER-01) prior to conducting sensor calibration. Confirmation of sensor cleanliness with the uPyxis 2.0 APP Cleanliness Check Function is required before proceeding to sensor calibration.*

See instructional video here <https://www.youtube.com/watch?v=hFmk2znyvjs&pp=ygUicHI4aXMgbWE%3D>

Two-Point (Beaker) PTSA Calibration

Two-point PTSA calibration for the ST-587 requires deionized (DI) water and 100-ppb, 200-ppb or 300-ppb PTSA standard solutions. (see the Optional Accessories Section 1.4). ***NOTE***: *For best results, the ST-587 Series sensor should be calibrated in a completely light-proof environment by covering the beaker with a towel.*

After confirming sensor cleanliness as outlined above, place the sensor into a beaker containing deionized (DI) water, then tap **ZERO CALIBRATION** in the uPyxis app. Please allow sufficient time (a few minutes) for the sensor to stabilize before performing the calibration.

After completing the zero calibration, place the sensor into Pyxis PTSA-100 calibration standard solution and tap **Slope CALIBRATION** in the uPyxis app. Enter the PTSA concentration 100 in the dialog window as in *Figure 9*.

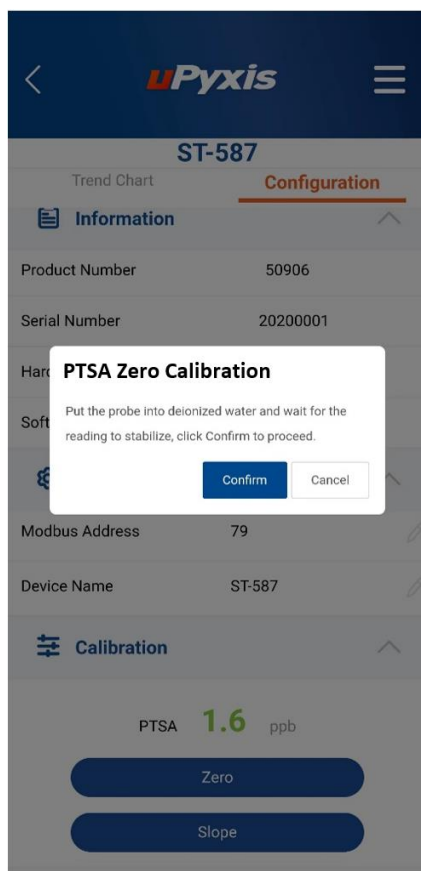

Figure 8 – PTSA Zero Calibration

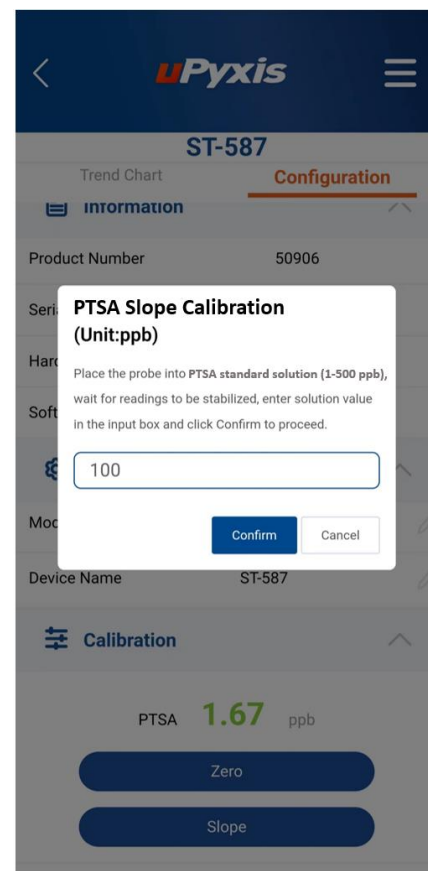

Figure 9 – PTSA Slope Calibration

4.1.2 Turbidity Calibration

Single Point (In-Situ) Turbidity Calibration

If you have confirmed the ST-587 sensor is clean by using the Cleanliness Check Function of the Diagnostic tab within uPyxis 2.0 (see section 4.1.4), users may conduct an in-situ slope calibration of Turbidity while the sensor is in operation. Users can tap **Slope CALIBRATION** and enter the handheld measured Turbidity value, then hit confirm. ***NOTE*** *If the sensor is dirty, it must be removed for proper optical channel cleaning with the Pyxis Probe Cleaning Solution (P/N SER-01) prior to conducting sensor calibration. Confirmation of sensor cleanliness with the uPyxis 2.0 APP Cleanliness Check Function is required before proceeding to sensor calibration.*

Two-Point (Beaker) Turbidity Calibration

Two-point Turbidity calibration for the ST-587 requires deionized (DI) water and a Formazine standard solution. Turbidity calibration uses 100 NTU Formazine standard solution (see the Optional Accessories Section 1.4). ***NOTE***: *The ST-587 Series sensor should be calibrated in a completely light-proof environment by covering the beaker with a towel.*

After confirming sensor cleanliness as outlined above, place the sensor into a beaker containing deionized (DI) water, then tap **ZERO CALIBRATION** in the uPyxis app. Please allow sufficient time (a few minutes) for the sensor to stabilize before performing the calibration.

After completing the zero calibration, place the sensor into Pyxis Formazine Turbidity 100NTU calibration standard solution and tap **Slope CALIBRATION** in the uPyxis app. Enter the NTU concentration 100 in the dialog window as in *Figure 11*.

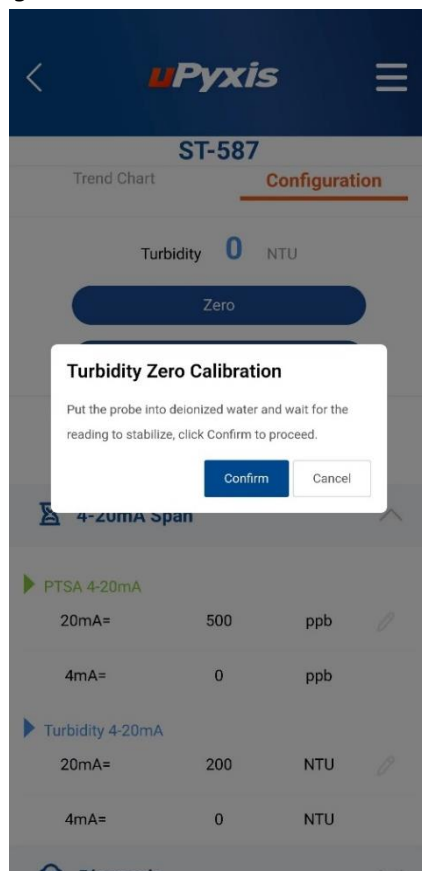

Figure 10 – Turbidity Zero Calibration

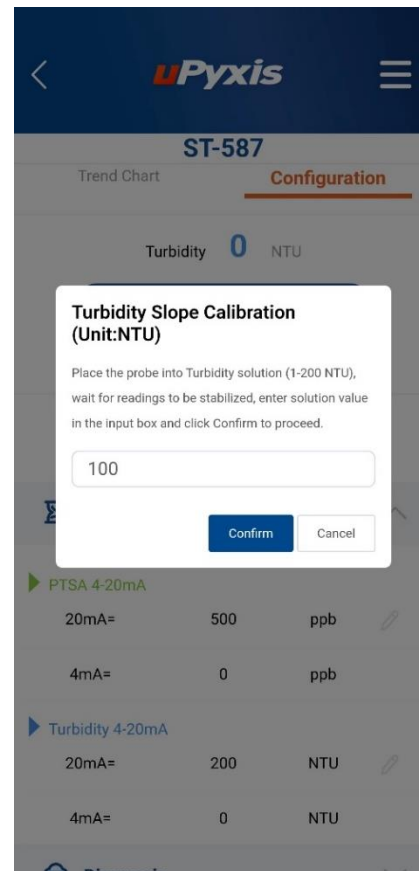

Figure 11 – Turbidity Slope Calibration

4.1.3 Adjusting the 4-20mA Span

From the Pyxis factory, the 4–20mA output of the ST-587 and ST-587SS sensor is scaled as follows:

ST-587 Sensor 4-20mA Scaling		
Unit of Measure	4mA Value	20mA Value
PTSA	0 ppb	500 ppb
Turbidity	0 NTU	200 NTU

Users may alter the output scale using **4-20mA Span** to change the PTSA and Turbidity value corresponding to the 20mA output (Figure 12 & Figure 13).

NOTE The 20mA value span adjustment may only be equal to or lower than the upper range detection limit of the sensor.

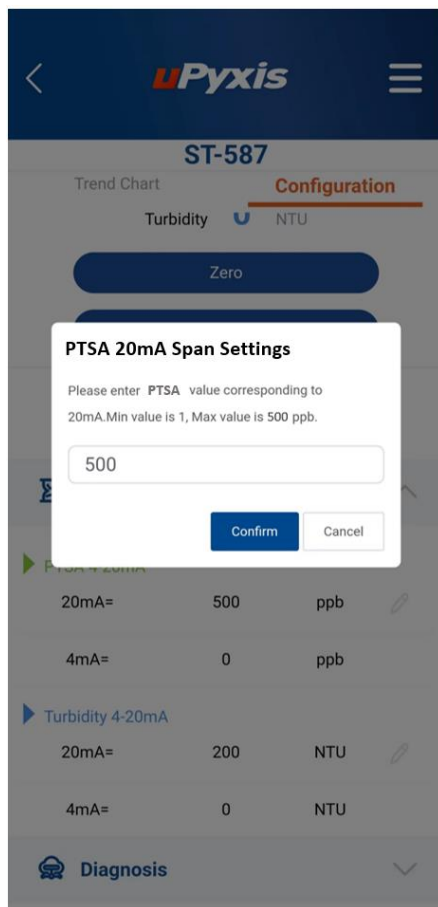

Figure 12 – Adjust 20mA Setting for PTSA

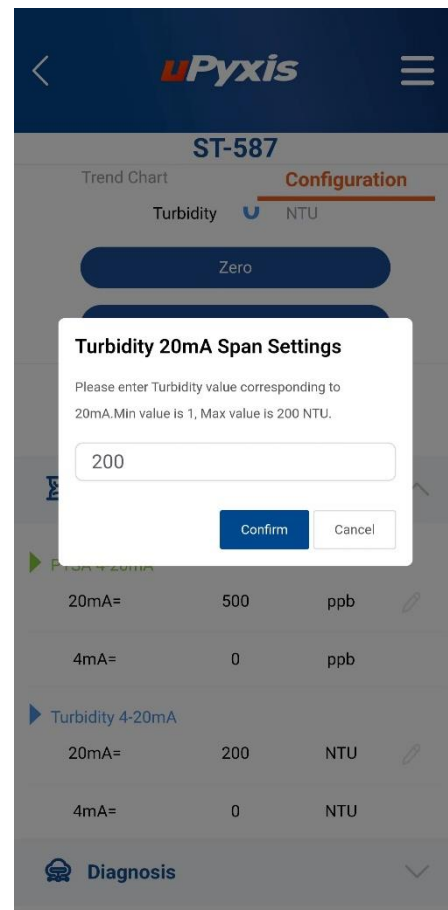

Figure 13 – Adjust 20mA Setting for turbidity

4.1.4 Diagnosis & Cleanliness check

Tap **Diagnosis** in the bottom of the **Configuration** page *Figure 14*.

When in the Diagnosis screen you can view the Diagnosis Condition of the device. This feature may be used for technical support when communicating with service@pyxis-lab.com.

To perform a sensor Cleanliness Check, first select the Diagnosis Condition which defines the fluid type that the ST-587 sensor is currently measuring, then click **Cleanliness Check**. If the sensor is clean, a **Clean** message will be shown. If the sensor is fouled, a **Becoming Dirty** or **Dirty** message will be shown. In this case, follow the procedure in the Methods to Cleaning the ST-587 section of this manual.



Figure 14 - Diagnostic Section

4.2 Calibration and Diagnosis with the uPyxis Desktop App

1) Download and install uPyxis Desktop APP from

<https://upyxis.pyxis-lab.com.cn/release/pc/uPyxis.Setup-latest.zip>

2) Connect a USB Type-C cable to the port at the bottom of the MA-CR and to the USB port of the laptop or computer. This will provide power the MA-CR from the laptop/computer. Connect the MA-CR to the ST-587 sensor. The MA-CR Bluetooth adapter will boost the 5V of the regular USB to 24V to power the sensor for use with uPyxis Desktop.



MA-WB Bluetooth Adapter – Bottom USB-C

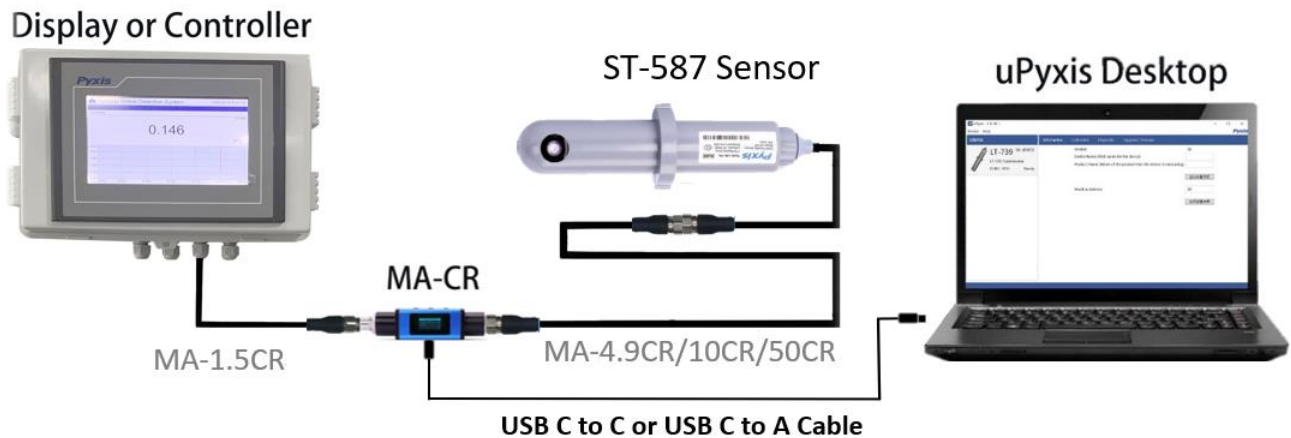

Figure 15 – ST-587 Probe / MA-CR / USB-C Cable connected to uPyxis Desktop

3) Set the MA-CR to operate in USB Mode by following the steps below.

- a. Once the MA-CR screen is powered Press ◀ or ▶ until you arrive at (USB to RS485) screen.
- b. Press the **OK** Button.
- c. Follow Prompts below to Enable USB feature. Once enabled, you may connect to uPyxis.



- 4) Open the desktop uPyxis APP.
- 5) Click Device to launch the connection option menu.
- 6) Select Connect via USB-RS485 (*Figure 16*).
- 7) Select the Comm Port to make a connection. Normally only one Comm port is identified by uPyxis (*Figure 17*). If more than one Comm port listed in the selection dropdown, you may try to select each one to see if a connection can be made. Alternatively, you may use the Windows Device Manager to identify the Comm Port that the Pyxis USB adapter is using.

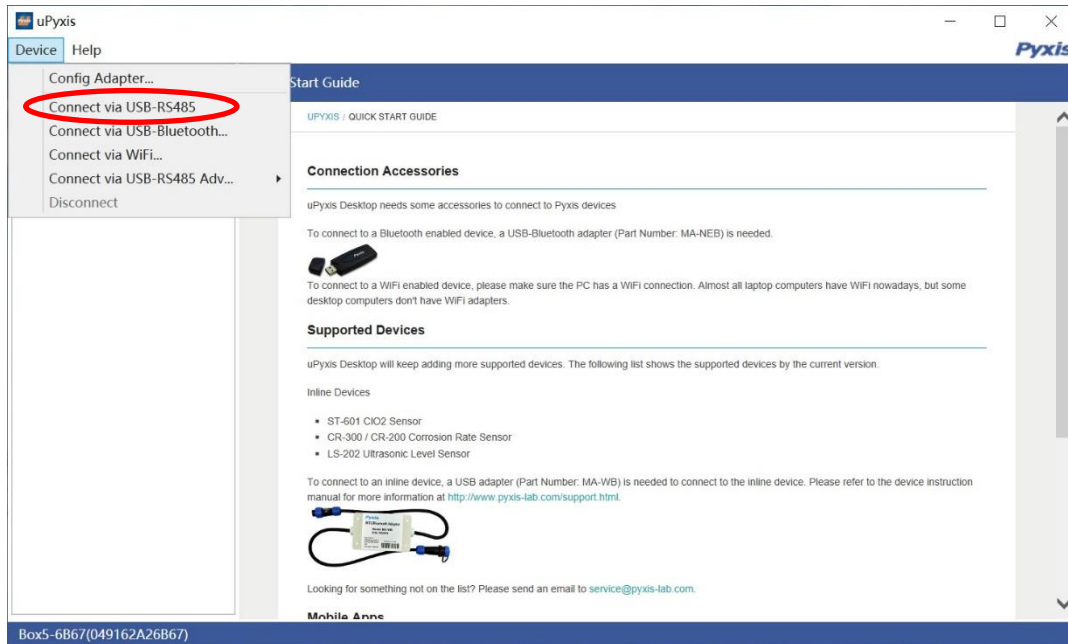

Figure 16 - Connection Options

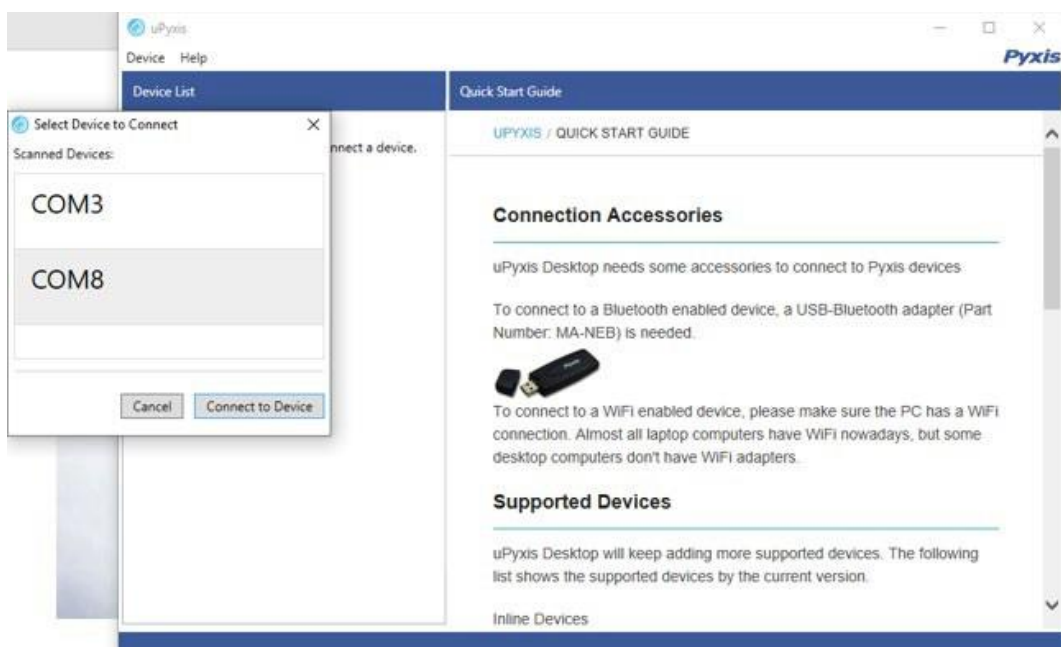

Figure 17 - Select a Comm port

After the connection is established, the ST-587 probe series number and current PTSA/Turbidity readings are displayed on the left of the information page (Figure 18). In this page, a device nickname and product name can be assigned to the probe. The sensor Modbus address can also be changed if desired.

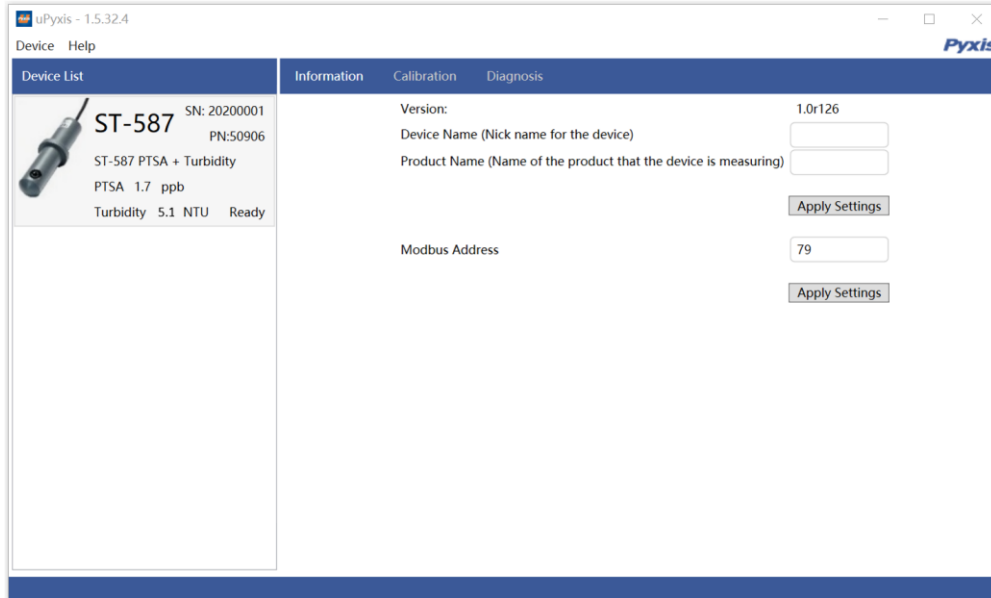

Figure 18 - Connected to a ST-587 probe and information page

To calibrate the device, click on **Calibration**. On the **Calibration** screen there are six calibration options:

- Turbidity: **Zero Calibration**, **Slope Calibration**, and **4-20mA Span**
- PTSA: **Zero Calibration**, **Slope Calibration**, and **4-20mA Span**

The screen also displays the reading of the device. The reading refresh rate is every 4 seconds.

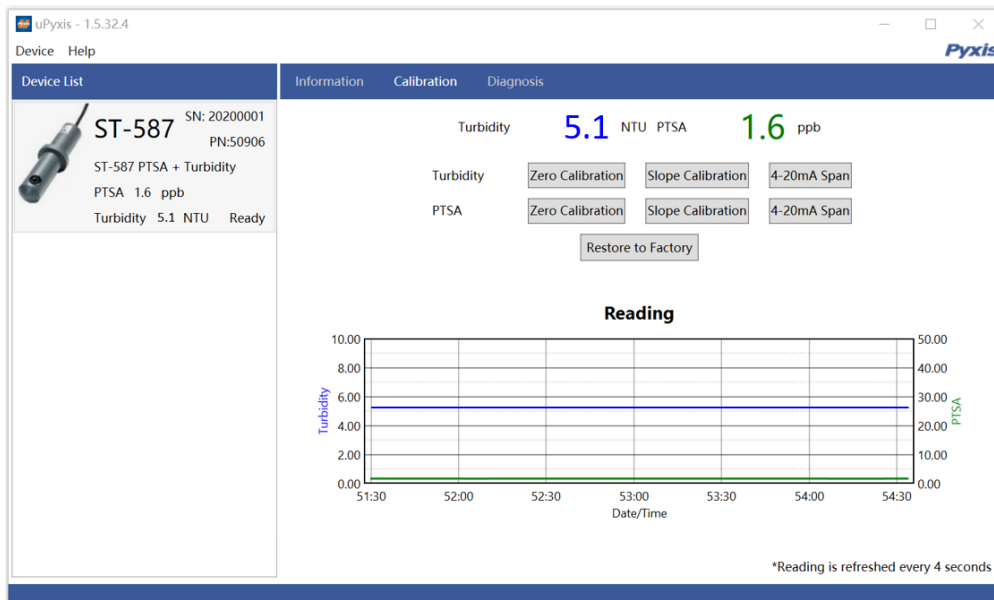

Figure 19 - Calibration Page

4.2.1 PTSA Calibration

Two-Point (Beaker) PTSA Calibration

Two-point PTSA calibration for the ST-587 requires deionized (DI) water and 100ppb, 200ppb or 300ppb PTSA standard solution. (see the **Optional Accessories** section). ***NOTE***: The ST-587 Series sensor should be calibrated in a completely light-proof environment by covering the beaker with a towel.

After confirming sensor cleanliness as outlined in Section 4.2.4, place the sensor into a beaker containing deionized (DI) water, then tap **ZERO CALIBRATION** in the uPyxis app. Please allow sufficient time (a few minutes) for the sensor to stabilize before performing the calibration.

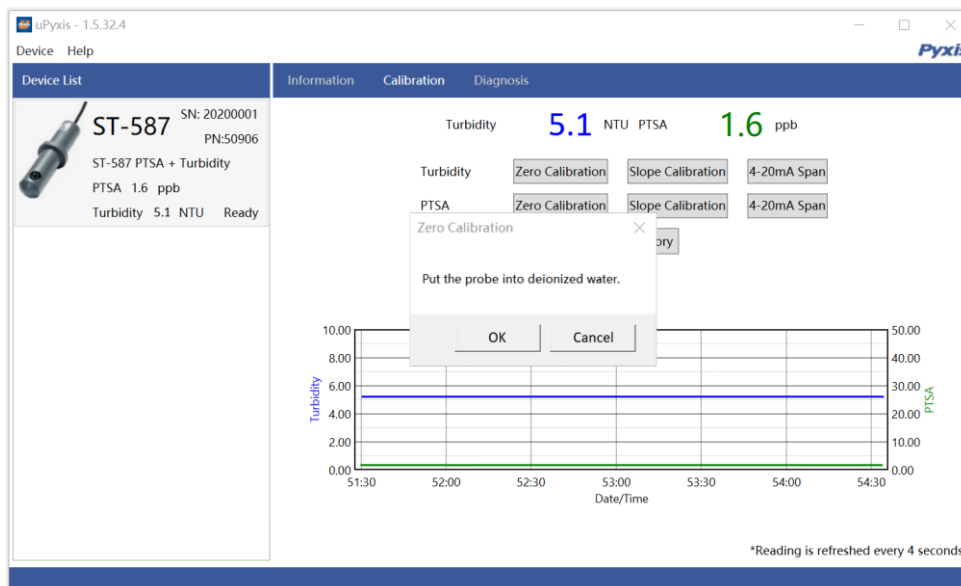

Figure 20 - Zero Calibration

After completing the zero calibration, place the sensor into Pyxis PTSA-100 calibration standard solution and tap **Slope CALIBRATION** in the uPyxis app. Enter the PTSA concentration 100 in the dialog window as in Figure 21.

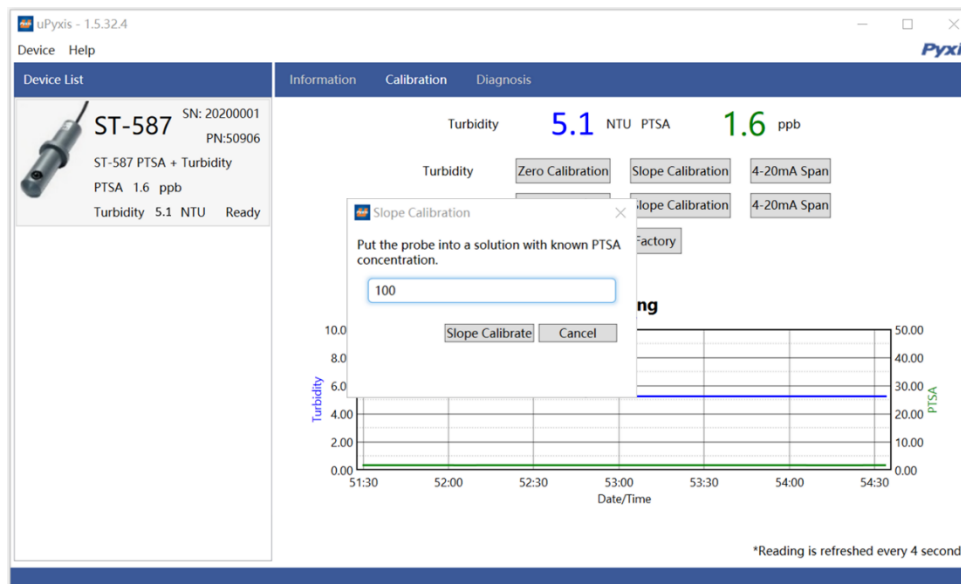

Figure 21 - Slope Calibration

4.2.2 Turbidity Calibration

Two-Point (Beaker) Turbidity Calibration

Two-point Turbidity calibration for the ST-587 requires deionized (DI) water and 100 NTU Formazine standard solution. (see the **Optional Accessories** section). ***NOTE***: The ST-587 Series sensor should be calibrated in a completely light-proof environment by covering the beaker with a towel.

After confirming sensor cleanliness as outlined in Section 4.2.4, place the sensor into a beaker containing deionized (DI) water, then tap **ZERO CALIBRATION** in the uPyxis app. Please allow sufficient time (a few minutes) for the sensor to stabilize before performing the calibration.

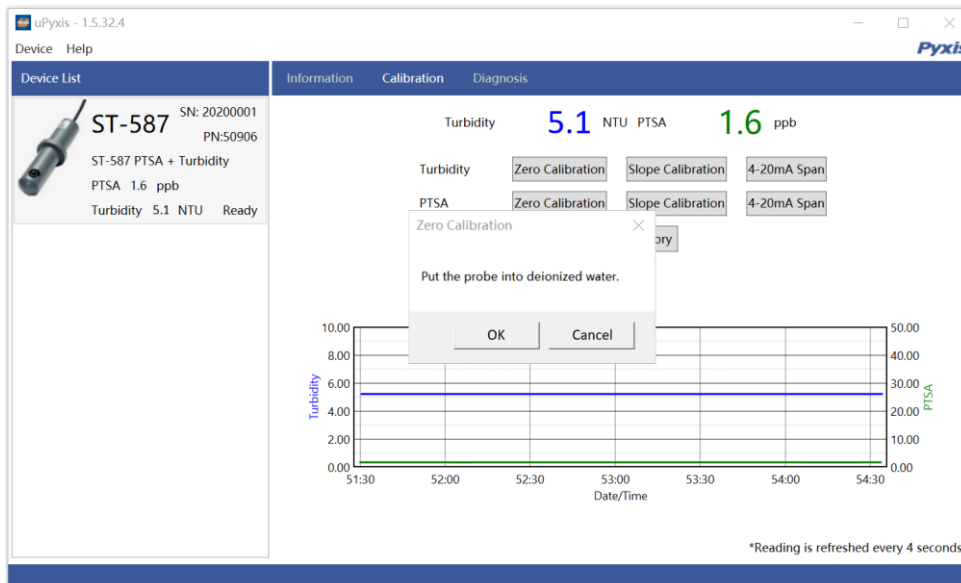

Figure 22 -Turbidity Zero Calibration

After completing the zero calibration, place the sensor into Pyxis Formazine Turbidity 100 NTU calibration standard solution and tap **Slope CALIBRATION** in the uPyxis app. Enter the Turbidity concentration 100 in the dialog window as in Figure 23.

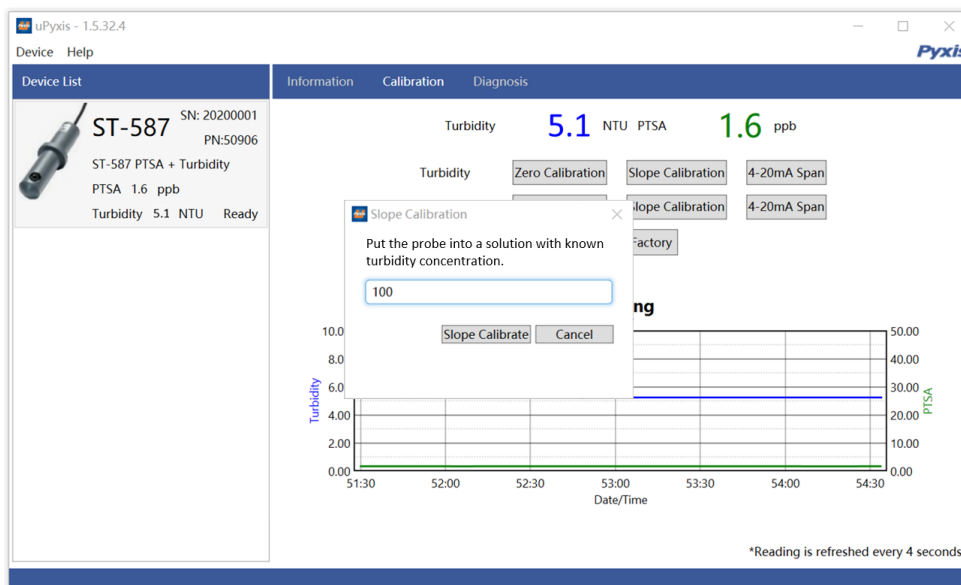

Figure 23 – Turbidity Slope Calibration

4.2.3 4-20mA Span

From the Pyxis factory, the 4–20mA output of the ST-587 and ST-587SS sensor is scaled as follows:

ST-587 Sensor 4-20mA Scaling		
Unit of Measure	4mA Value	20mA Value
PTSA	0 ppb	500 ppb
Turbidity	0 NTU	200 NTU

Users may alter the output scale using **4-20mA Span** to change the PTSA or Turbidity value corresponding to the 20mA output (*Figure 24 & Figure 25*). ***NOTE*** The 20mA value span adjustment may only be equal to or lower than the upper range detection limit of the sensor.

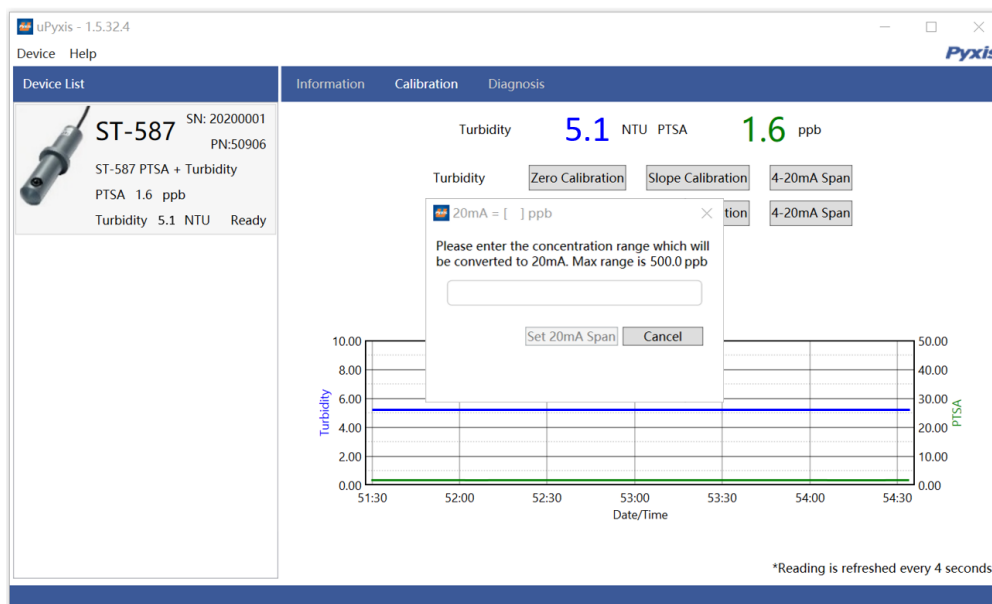

Figure 24 Set 4-20mA Span for PTSA

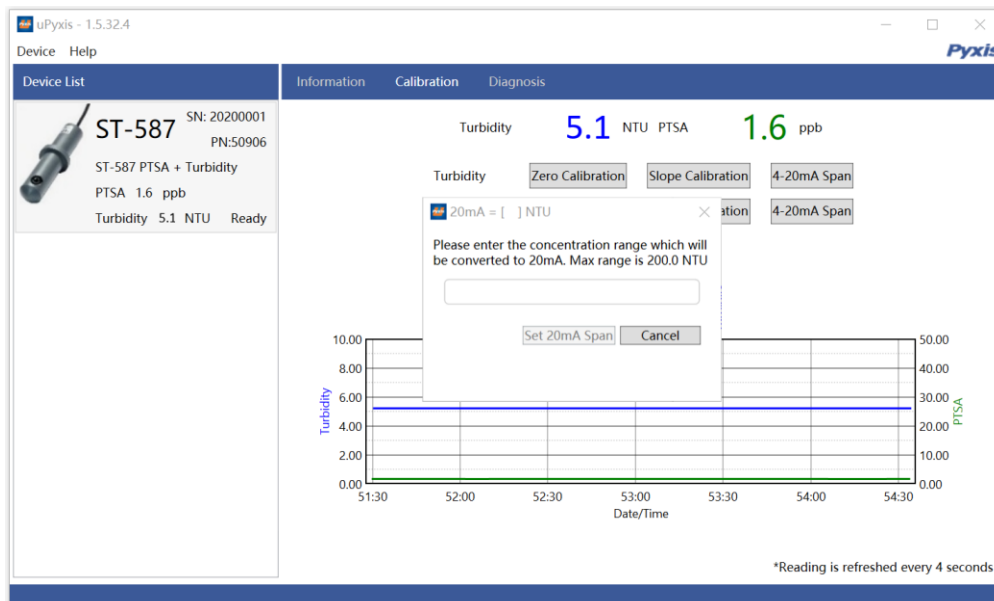

Figure 25 Set 4-20mA Span for turbidity

4.2.4 Diagnosis & Cleanliness check

To check the diagnostic data of the ST-587 Series, click on **Diagnosis**. When in the Diagnosis screen you can view the Diagnosis Condition of the device. The meta-data values listed (14 total) may be used for technical support when communicating with service@pyxis-lab.com

To perform a sensor Cleanliness Check, first select the Diagnosis Condition which defines the fluid type that the ST-587 sensor is currently measuring, then click **Cleanliness Check**. If the sensor is clean, a **Clean** message will be shown. If the sensor is fouled, a **Becoming Dirty** or **Dirty** message will be shown. In this case, follow the procedure in the Sensor Cleaning & Maintenance Section 6 of this manual.

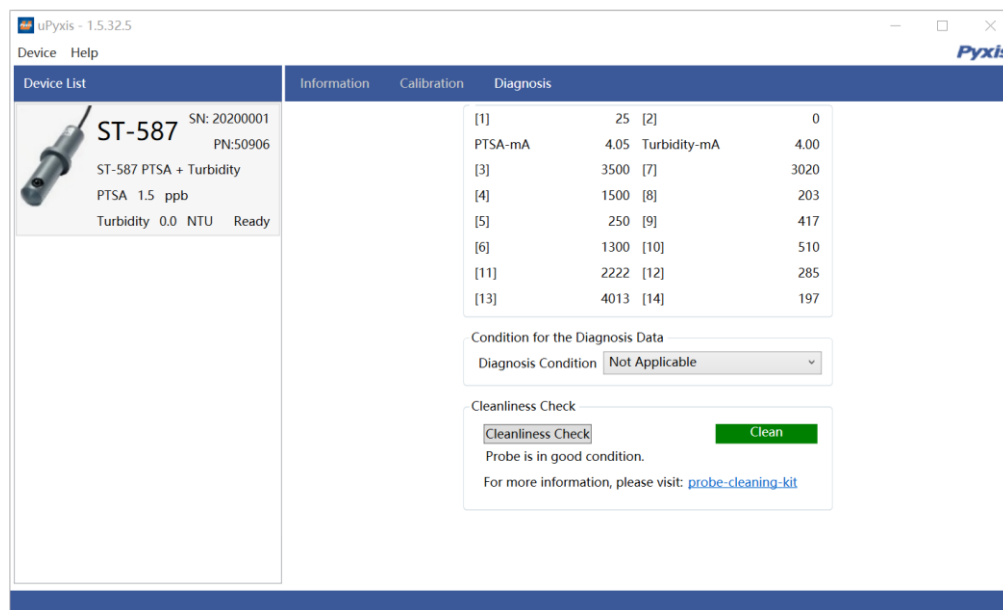

Figure 26 - Diagnostic Interface

5. Modbus RTU

The ST-587 Series sensors are configured as a Modbus slave device. In addition to the turbidity NTU and PTSA ppb value, many operational parameters, including cleanliness condition, warning and error messages, are available via a Modbus RTU connection. Contact Pyxis Lab Customer Service (service@pyxis-lab.com) for more information.

6. Sensor Cleaning and Maintenance

The ST-587 Series sensors are designed to provide reliable and continuous PTSA and Turbidity readings even when installed in moderately contaminated samples as high as 150NTU, while offering the user an in-situ cleanliness diagnostic check to predict need for cleaning PRIOR to and upset issue. Although the optics are compensated for the effects of moderate fouling, heavy fouling will prevent the light from reaching the sensor, resulting in false readings and the potential for product overfeed if the ST-587 sensor is used as part of an automated control system. When used to control product dosing, it is suggested that the automation system be configured to provide backup to limit potential product overfeed, for example by limiting pump size or duration, or by alarming if the pumping rate exceeds a desired maximum limit.

The Pyxis Probe Cleaning Solution Kit (P/N: SER-01) is a uniquely designed cleaning solution designed to effectively remove the most common inorganic foulants and contaminants from the quartz optical channel of the ST-587 series sensor. The kit is provided with 500mL bottle of cleaning solution (sufficient for up to 5-10 cleanings) as well as glass jar, soft bristle brush and Q-Tips. The **Inline Probe Cleaning Solution Kit** (P/N: SER-01) can be purchased at our online E- Store [Inline Sensor Cleaning Kit | Pyxis Lab® \(pyxis-lab.com\)](https://www.pyxis-lab.com/inline-sensor-cleaning-kit)

Please refer to this link for a detailed instructional video on how to use uPyxis for diagnosis, cleaning and calibration of Pyxis ST-Series sensors.

<https://www.youtube.com/watch?v=hFmk2znyvjs&pp=ygUlChI4aXMgbWE%3D>



Figure 19. Pyxis Probe Cleaning Solution Kit (P/N: SER-01)

Probe Cleaning Procedure

To clean the ST-587 Series sensor, soak the lower half of the sensor in approximately 50-100 mL inline probe cleaning solution for 5-15 minutes depending on the severity of foulant. Use the small, soft bristle brush and Q-Tips cotton swabs as necessary to remove any contaminants in the sensor quartz tube optical channel. Rinse the sensor optical channel with distilled water and then check for the flashing blue light inside the sensor quartz tube. Insert the sensor into DI water in a beaker and use [uPyxis cleanliness check function](#) to confirm you have effectively cleaned the sensor optical channel before proceeding to sensor calibration.

7. Other Common Troubleshooting Issues

If the ST-587 Series sensor output signal is not stable and fluctuates significantly, make an additional ground connection — connect the Green (shield, earth ground) wire to a conductor that contacts the sample water electrically such as a metal pipe adjacent to the ST-587 Series tee. Likewise, you may consider grounding the controller itself to a conductor wire that contacts the sample water electrically.

8. Contact Us

Pyxis Lab, Inc
21242 Spell Circle
Tomball, TX 77375
Phone: +1 (866) 203-8397
Service: service@pyxis-lab.com
Orders: order@pyxis-lab.com
Web: www.pyxis-lab.com