

ST-540 Series

Inline NDSA Sensors





The information contained in this manual may be confidential and proprietary and is the property of Pyxis Lab, Inc. Information disclosed herein shall not be used to manufacture, construct, or otherwise reproduce the goods described. Information disclosed herein shall not be disclosed to others or made public in any manner without the express written consent of Pyxis Lab, Inc.

Limited Warranty

Pyxis Lab warrants its products for defects in materials and workmanship. Pyxis Lab will, at its option, repair or replace instrument components that prove to be defective with new or remanufactured components (i.e., equivalent to new). The warranty set forth is exclusive and no other warranty, whether written or oral, is expressed or implied.

Device Warranty Term

The Pyxis warranty term for the ST-540 sensor is thirteen (13) months from original shipment from Pyxis. In no event shall the standard limited warranty coverage extend beyond thirteen (13) months from original shipment date.

Warranty Service

Damaged or dysfunctional instruments may be returned to Pyxis for repair or replacement. In some instances, replacement instruments may be available for short duration loan or lease.

Pyxis warrants that any labor services provided shall conform to the reasonable standards of technical competency and performance effective at the time of delivery. All service interventions are to be reviewed and authorized as correct and complete at the completion of the service by a customer representative or designate. Pyxis warrants these services for 30 days after the authorization and will correct any qualifying deficiency in labor provided that the labor service deficiency is exactly related to the originating event. No other remedy, other than the provision of labor services, may be applicable.

Repair components (parts and materials), but not consumables, provided in the course of a repair, or purchased individually, are warranted for 90 days ex-works for materials and workmanship. In no event will the incorporation of a warranted repair component into an instrument extend the whole instrument's warranty beyond its original term.

Warranty Shipping

A Repair Authorization Number (RA) must be obtained from Pyxis Technical Support before any product can be returned to the factory. Pyxis will pay freight charges to ship replacement or repaired products back to the customer. The customer shall pay freight charges for returning products to Pyxis. Any product returned to the factory without an RA number will be returned to the customer.

Pyxis Technical Support

Contact Pyxis Technical Support at service@pyxis-lab.com or 1-866-203-8397 (Mo-Fri 7:00AM-5PM MT)

Table of Contents

1	Introduction.....	4
1.1	Features of the Pyxis ST-540 Series.....	4
1.2	Specifications.....	5
1.3	Un-packing Instrument.....	5
1.4	Standard Accessories.....	6
1.5	Optional Accessories	6
2	Installation	7
3	Quick 4-20mA Start	9
4	Calibration and Diagnosis	9
4.1	Calibration and Diagnosis with uPyxis Mobile App.....	10
4.1.1	Calibration	11
4.1.2	4-20mA Span Settings.....	11
4.1.3	Diagnosis	12
4.2	Calibration and Diagnosis with uPyxis Desktop App.....	13
4.2.1	Calibration	16
4.2.2	4-20mA Span Settings.....	16
4.2.3	Diagnosis	16
4.3	Calibration through the Controller	18
5	Modbus RTU	18
6	Sensor Cleaning and Maintenance	19
6.1	Cleaning Procedure	19
6.2	Other Common Troubleshooting Issues.....	20

1 Introduction

The ST-540 Series are inline fluorometers designed for those desiring to conduct research and development of NDSA traced boiler or process water treatment programs. The ST-540 Series offer direct measurement of NDSA (Napthenic Disulfonic Acid CAS# 1655-29-4) utilizing LED light sources for use in boiler water and boiler feedwater measurement applications.

The ST-540 Series offers Pyxis proprietary algorithms to determine the concentrations of NDSA in a range of 0-2,500ppb while simultaneously measuring light loss through the optical channel to determine sensor cleanliness. The ST-540 Series offer a combination of 4-20mA as well as RS-485 Modbus output signals and is Bluetooth Enabled for wireless cleanliness diagnostics and calibration when used with MA-WB or PowerPACK Series Bluetooth Adapters and the uPyxis APP for Mobile or Desktop devices. The ST-540 Series is provided in both UPVC and 304 stainless steel for use in a cooling/process water or cooled/pressurized sample (<120°F) of boiler water or boiler feedwater. Each sensor is provided with a 1.5m bulk-head cable with 7-Pin quick adapter and 1.5m flying lead cable with 7-Pin quick adapter, enabling rapid wiring to any microprocessor controller, PLC or DCS system. The MA-WB Bluetooth adapter may be inserted between ST-540 sensor cable and flying lead cable to enable wireless access for use with the uPyxis Mobile or Desktop APPs for diagnosis and calibration.

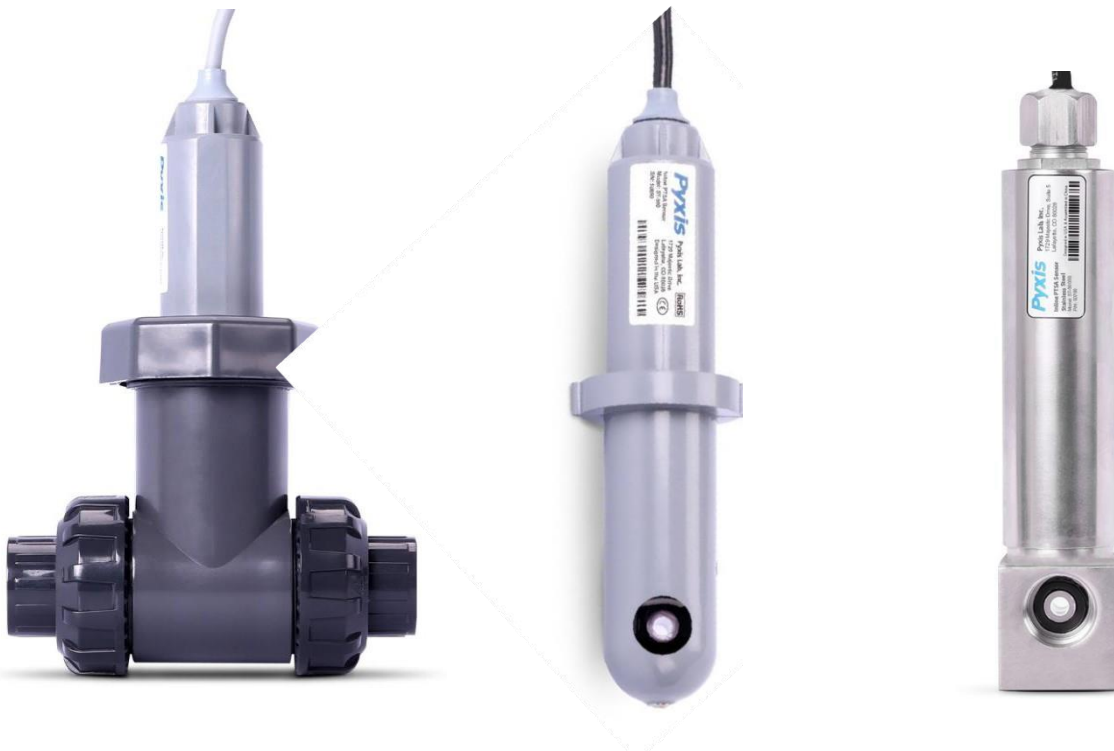

ST-540A (UPVC) and ST-540SS (304-SS) Inline NDSA Fluorometers

1.1 Features of the Pyxis ST-540 Series

The ST-540 series includes the following features:

- Easy calibration using uPyxis mobile or desktop app.
- Automatic compensation for turbidity up to 150 NTU and color created by up to 10 ppm iron or equivalent to 10 ppm humic acid.
- Diagnostic information (sensor fouling, color or turbidity over range, failure modes) are available in uPyxis app or via Modbus RTU.
- Offered in both UPVC and 304 stainless steel formats depending on pressure of the application

1.2 Specifications

Item	ST-540SS	ST-540SS-N	ST-540SS-HR	ST-540A
P/N	50667	50694	58982	50621
Fluorescein Output Scale <i>4-20mA Default</i>	0-500ppb	0-20ppb	0-2,500ppb	0-500ppb
4-20mA SPAN <i>Adjustable via uPyxis</i>	20mA SPAN Value May Be Adjusted to a lower value if desired via uPyxis APP			
NDSA Resolution	+/- 1.0 ppb	+/- 0.1 ppb	+/- 3.0 ppb	+/- 1.0 ppb
Calibration	Two Point Calibration Against DI Water + NDSA Standard Solution			
Power Supply	12-36VDC, Power Consumption – 1W			
Outputs	Isolated 4 – 20 mA Analog Outputs & Isolated RS-485 Digital Output -7Pin			
Installation	¾-inch FNPT Threaded Ports			ST-001 Inline Tee Assmbl. (¾-inch)
Weight	2.5lbs (1,148g)			0.37lbs (170g)
Operational Pressure	290 psi (20 Bar)			100 psi (6.9 Bar)
Operating Temperature	4 °C – 49 °C (40 – 120 °F)			
Storage Temperature	-20 °C – 60 °C (-4 – 140 °F)			
Material	304 Stainless Steel			UPVC
Rating	IP67, Fully Dustproof & Waterproof			
Regulation	CE / RoHS / UKCA			
Dimension (L x W x H)	Length 6.8 inch (172.7 mm), body diameter 1.44 Inch (36.6 mm)			
Cable Length	1.5meter terminated w/IP67 adapter + 1.5meter flying lead w/IP67 adapters			

Specifications are subject to change without notice

1.3 Un-packing Instrument

Remove the instrument and accessories from the shipping container and inspect each item for any damage that may have occurred during shipping. Verify that all accessory items are included. If any item is missing or damaged, please contact Pyxis Lab Customer Service at service@pyxis-lab.com.

1.4 Standard Accessories

- ST-540 Series sensor (two versions available)
 - ST-540A includes ST-001 Inline UPVC Tee Assembly (¾-inch)
 - ST-540SS / ST-540SS-N / ST-540SS-HR are stainless steel with ¾-inch FNPT input/output
- Attached 1.5meter bulkhead cable with 7-Pin adapter
- Loose 1.5meter flying lead cable with 7-Pin adapter
- The Operation Manual is available from service@pyxis-lab.com

1.5 Optional / Replacement Accessories

Optional Accessories Information

P/N

ST-001 Inline Tee Assembly Spare (<i>3/4" FNPT Inline Tee Assembly</i>)	50704
NDSA-10 (<i>NDSA Calibration Standard 10ppb / 500mL</i>)	NDSA-100
NDSA-100 (<i>NDSA Calibration Standard 100ppb / 500mL</i>)	NDSA-100
NDSA-1000 (<i>NDSA Calibration Standard 1000ppb / 500mL</i>)	NDSA-1000
Pyxis Probe Cleaning Kit (<i>Includes Sensor Cleaner 500mL + Accessories</i>)	SER-01
MA-WB Bluetooth Adapter (<i>Pyxis Bluetooth Adapter for 7Pin Pyxis Sensors</i>)	MA-WB
MA-NEB Bluetooth/USB Adapter (<i>Enables Bluetooth for Desktop and uPyxis APP</i>)	MA-NEB
PowerPACK-1 (<i>Single Chanel Auxiliary Power Supply w/Bluetooth For Pyxis Sensors</i>)	MA-BLE-1
PowerPACK-4 (<i>Four Chanel Auxiliary Power Supply w/Bluetooth For Pyxis Sensors</i>)	MA-BLE-4
SP-395N Handheld NDSA Analyzer (<i>NDSA 0-100ppb</i>)	50226
MA-C10 (<i>10' Extension Cable for 7Pin Pyxis Sensors</i>)	50738
MA-C50 (<i>50' Extension Cable for 7Pin Pyxis Sensors</i>)	50705

2 Installation

ST-540SS / ST-540SS-N / ST-540SS-HR - The ST-540SS stainless steel sensors are designed for higher pressure applications (<290psi) and offers two 3/4 inch FNPT ports (sample in and out). It is recommended that two 3/4 inch NPT to 1/4 inch tubing adaptor are used to connect the sensor to the sampling system. Sample water entering the sensor must be cooled down to below 120 °F (49 °C). The sensor can be held by a 1.75-inch pipe clamp or mounted to a panel with four screws. See Figure 1 for ST-540SS series dimensions.

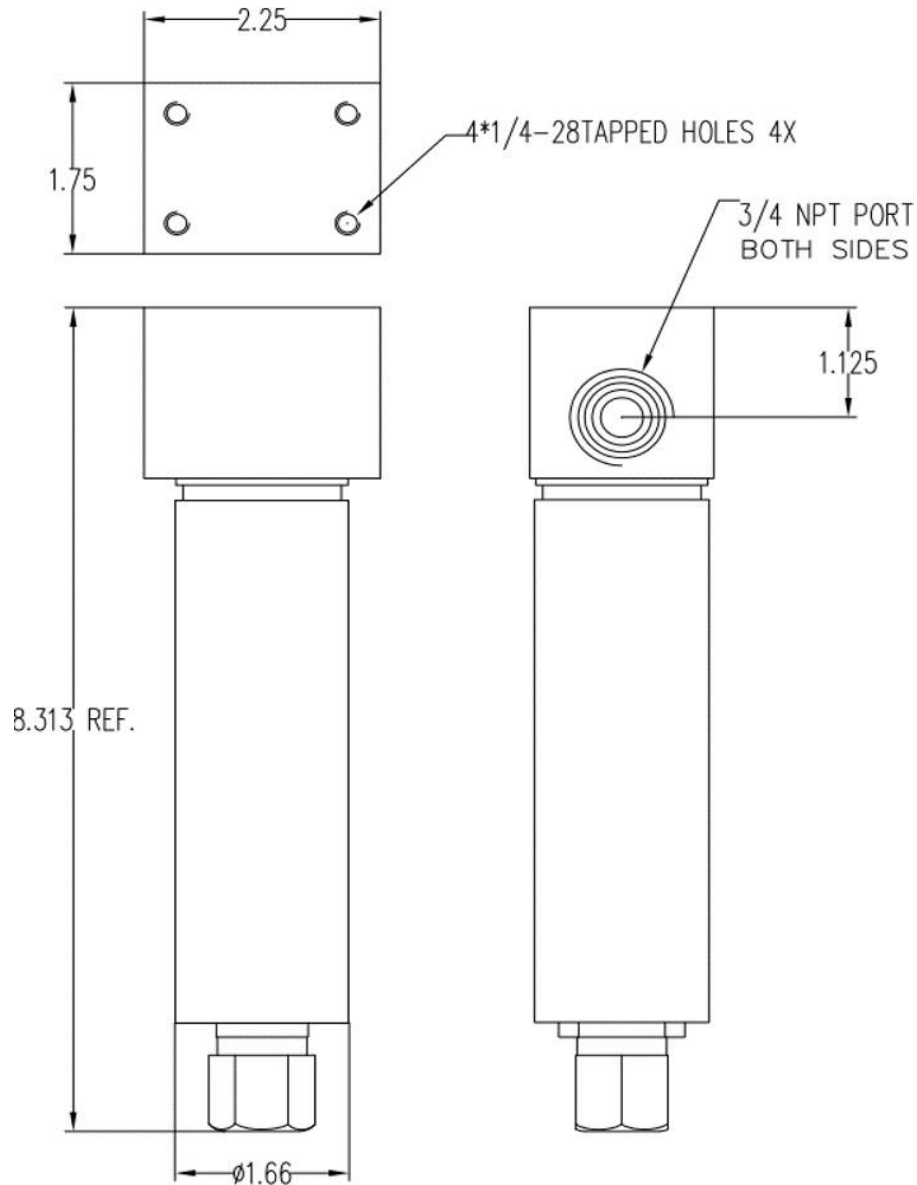

Figure 1. Dimension of the ST-540SS / ST-540SS-N

ST-540A - The ST-540A is a UPVC version of the sensor designed for lower pressure applications (<100psi). This sensor will come equipped with an ST-001 inline Tee assembly offered in 3/4-inch FNPT inlet and outlet with socket weld and threaded adapters and unions. This sensor should be installed in a standard 3/4-inch NPT PVC piping bypass network with isolation valves. It is recommended that this sensor be installed with flow in a vertical format entering the bottom of the tee and existing the top. See Figure 1A for ST-540A dimensions.

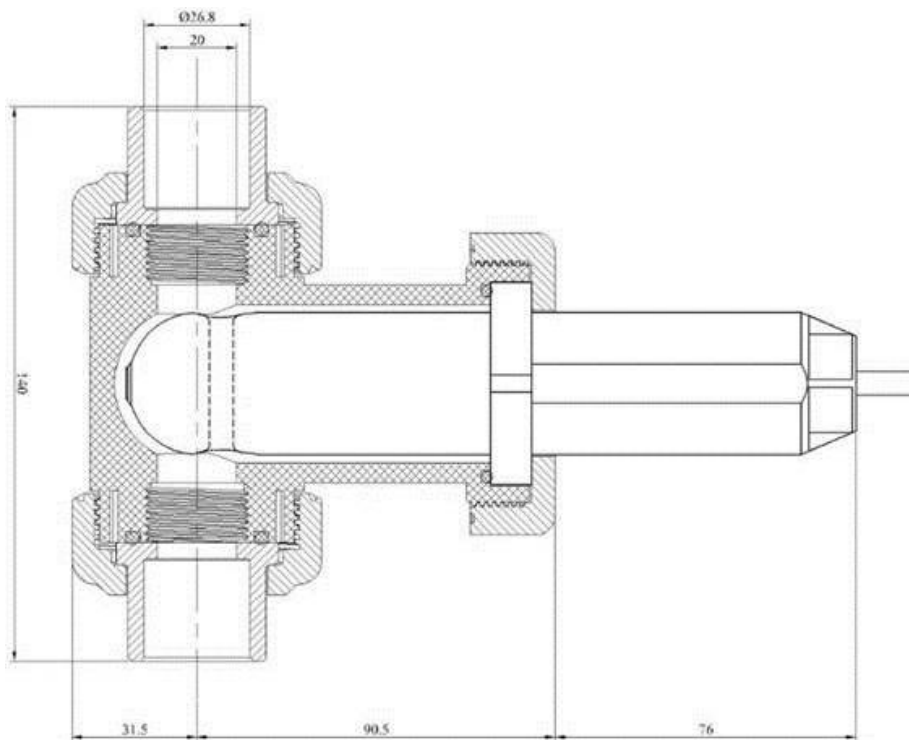

Figure 2A. Dimension of the ST-540A

3 Quick 4-20mA Start

Follow the wiring table below to connect the ST-540 series sensor to a controller.

Wire Color	Designation
Red	24 V +
Black	Power Ground and internally connected to 4-20mA-
White	4-20 mA +
Green	NO CONNECT NOT USED
Blue	RS-485 A
Yellow	RS-485 B
Clear	Shield, Solution ground

**Note*: The 24V power ground and the 4-20 mA- return are internally connected.*

The ST-540 series provides a passive 4-20mA output. It is NOT LOOP POWERED. The 24VDC power supply are wired separately. The black wire from the ST-540 series serves as both 24- (Power Ground) and 4-20mA-. If the 24V power ground and the 4-20 mA- return in the controller are internally connected (non-isolated 4-20mA input), it is unnecessary to connect any wire to the 4-20 mA negative terminal in the controller. If they are not internally connected in the controller, a jumper wire may be necessary in the controller from 24- (Power Ground) to the 4-20mA- terminal. If a separate DC power supplier other than that from the controller is used, make sure that the output from the power supply is rated for 22-26 VDC @ 65mA. Detailed wiring diagrams for common controllers are available from service@pyxis-lab.com

4 Calibration and Diagnosis

The ST-540 series sensor can be calibrated in a two-point (zero + slope) procedure using a deionized water sample and a standard containing 100 ppb NDSA. The sensor can also be calibrated by a single point method. The calibration solution could be the sample water itself. The concentration of NDSA in the sample water can be determined by using a Pyxis SP-395N (Part # 50226) or similar offline fluorometer or calculated from the concentration of any measurable species in the sample water such as polymer, phosphate, or molybdate.

Direct sunlight or indoor light on the ST-540 series sensor should be avoided although it is not necessary to completely shield the ST-540 series from the ambient light during both the zero point and slope calibrations.

4.1 Calibration and Diagnosis with uPyxis Mobile App

Connect and power the ST-540 series sensor using the Pyxis Bluetooth adapter (P/N: MA-WB) as shown in the following connection diagram. The power should be sourced from a 24 VDC power terminal of a controller. Alternatively, if a controller is not available, please purchase a Pyxis PowerPack-1 (MA-BLE-1) or PowerPack-4 (MA-BLE-4) auxiliary power supply with Bluetooth, or an alternative 24 V power supply that can directly connect to the ST-540 sensor with proper cable connectors from Pyxis.

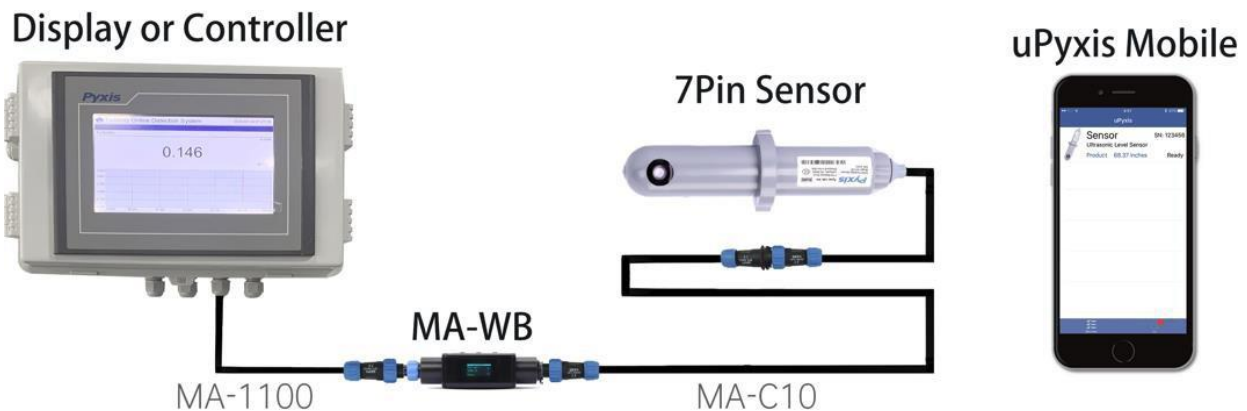

Figure 3. ST-540 series connected to controller/display and inserted Pyxis MA-WB Bluetooth adapter

Download and install uPyxis app from **App Store** or **Google Play**.

Turn on Bluetooth in the phone (please do not pair your Bluetooth to uPyxis. The uPyxis app will do the pairing). Open the uPyxis app in the phone. Swipe down to refresh the phone screen to scan the available Pyxis Bluetooth devices. The discovered devices will be listed (Figure 3).



Tap the discovered ST-540 series sensor to connect to the sensor. The uPyxis app can identify the sensor type if multiple Pyxis sensors are discovered in the scan. For legacy old generation sensors, a dialog message window will be displayed to ask the user to tell the app the sensor type. In this case, please select the ST-540 series sensor from the dropdown list provided in the app.

As shown in Figure 4, the calibration page after uPyxis is connected to the sensor via the Pyxis Bluetooth adapter displays the current NDSA value recorded by the sensor. Three functional tabs are available in this page: **Zero Calibration**, **Slope Calibration**, and **4-20mA Span**.

4.1.1 Calibration

Place the sensor in deionized water and tap **Zero Calibration** to carry out the zero-point calibration.

Place the sensor in a NDSA standard and tap **Slope Calibration** to carry out the slope calibration. Enter the NDSA concentration in the dialog window as in Figure 5. For the best result, the NDSA standard should be in the range of 100 ppb for the ST-540SS and ST-540A and 10ppb for the ST-540SS-N.

The calibration solution could be the sample water itself. The concentration of NDSA in the sample water can be determined with using a Pyxis SP-395N (or similar offline fluorometer) or calculated from the concentration of any measurable species in the sample water such as polymer, phosphate, or molybdate.

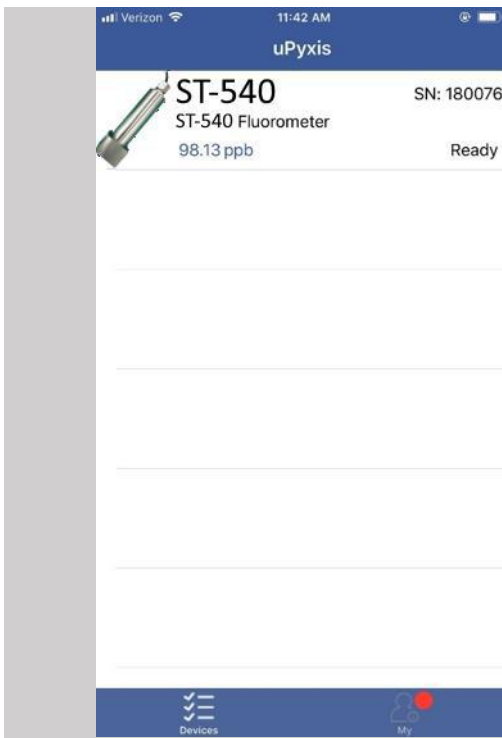

Figure 4. A ST-540 series discovered by Bluetooth scan

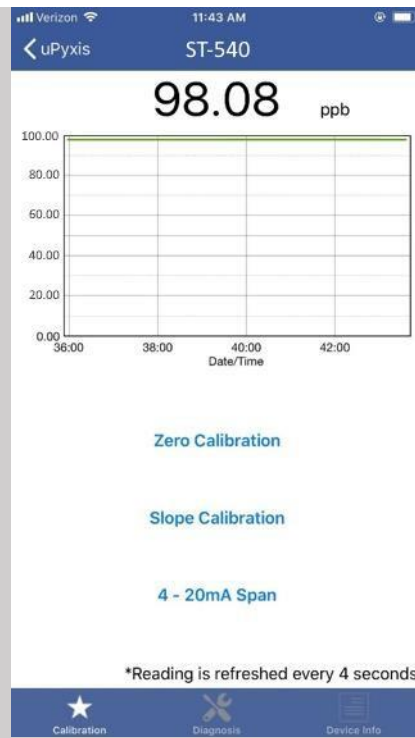

Figure 5. Calibration page

4.1.2 4-20mA Span Settings

The default 4-20mA span is 20 mA = 500 ppb NDSA and 4 mA = 0 ppb NDSA. Users may alter the output scale using **4-20mA Span** to change the NDSA value corresponding to the 20mA output (Figure 6). The maximum upper limitation of the 20mA output is 500 ppb when using this function.

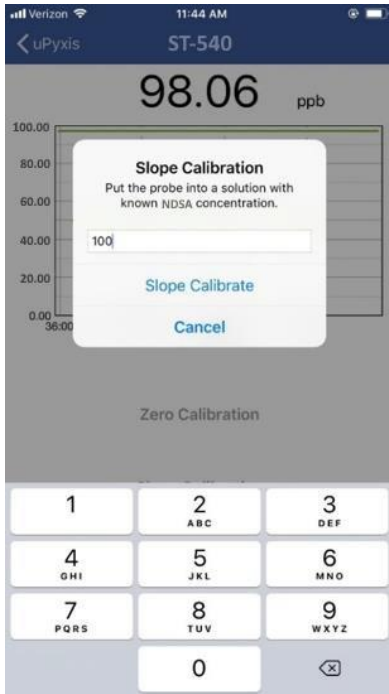

Figure 6. Enter NDSA concentration

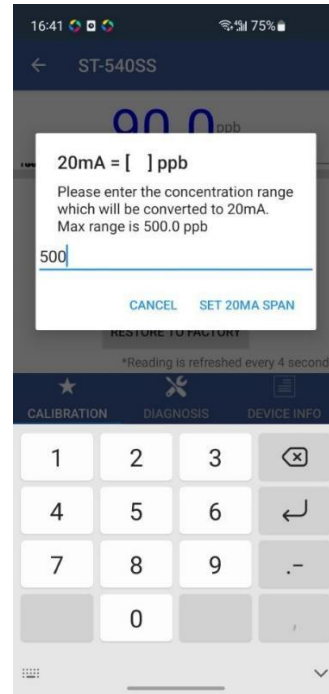

Figure 7. Enter NDSA concentration to set 20mA

4.1.3 Diagnosis

Tap **Diagnosis** in the bottom of the app page to launch the diagnosis page (Figures 7 and 8).

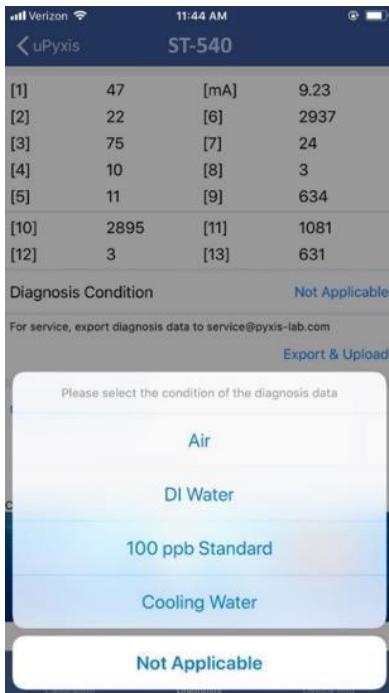

Figure 7. Select diagnosis condition

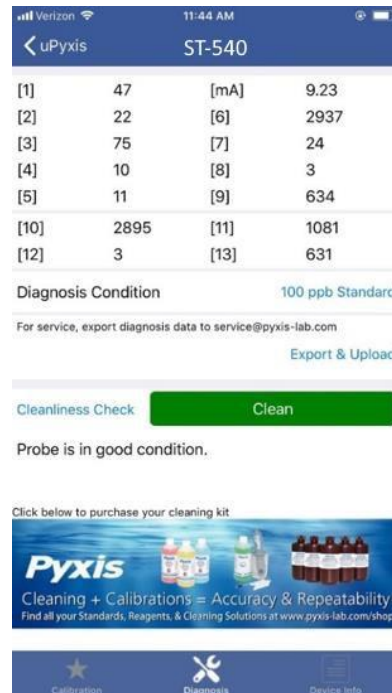

Figure 8. Cleanliness check result and raw data

In this page, the raw data measured by the sensor is displayed. To help troubleshooting possible issues with the sensor, please save images of these data when the sensor is respectively placed in a clean water (tap water or deionized water), in a NDSA standard, and in the sample that the sensor is intended for.

In the diagnosis page, the sensor cleanliness check can be performed. Please place the sensor in a NDSA standard or other water samples available and select the sample condition by tapping **Diagnosis Condition** (Figure 7). Tap **Cleanliness Check** to carry out the check. If the sensor is clean, a green **Clean** message tab will be shown (Figure 8). If the sensor is severely fouled, a red **Dirty** message tab will be shown. In this case, please clean the sensor according to the procedure in Section 6. If the sensor is partially fouled, a yellow **Becoming Dirty** message tab will be shown.

4.2 Calibration and Diagnosis with uPyxis Desktop App

Download and install uPyxis desktop app from

<https://upyxis.pyxis-lab.com.cn/release/pc/uPyxis.Setup-latest.zip>

To connect the ST-540 series sensor to a computer via Bluetooth, insert the Pyxis MA-NEB adapter for PC into your laptop or desktop computer. Insert the Pyxis MA-WB Bluetooth adapter between the ST-540 series sensor and the connected controller/display. Refer to the diagram below

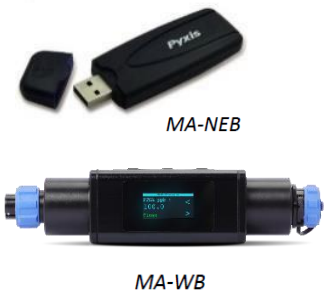

Display or Controller

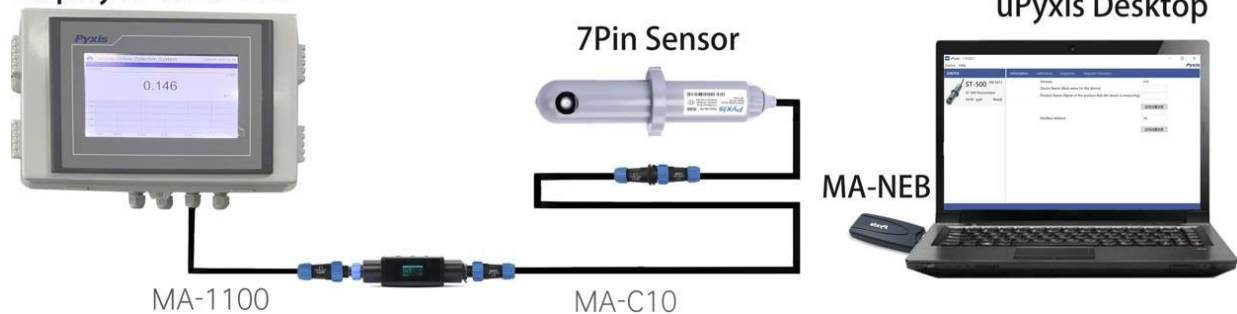

Figure 8. Connect the ST-540 series to a computer via MA-NEB and MA-WB Bluetooth adapters

Establish connection between uPyxis app and the ST-540 series sensor through the following steps:

1. Open the desktop uPyxis app.
2. Click **Device** tap to launch the connection option menu.
3. Select **Connect via USB-Bluetooth** (Figure 10).
4. Select the Comm Port to make a connection (Figure 11) (normally only one Comm port is identified by uPyxis. If more than one Comm port listed in the selection dropdown, you may try to select each one to see if a connection can be made. Alternatively, you may use the Windows Device Manager to identify the Comm Port that the Pyxis USB adapter is used.)

After the connection is established, the ST-540 sensor series number and current NDSA reading are displayed on the left of the information page (Figure 12). In this page, a nickname can be assigned to the sensor. The sensor Modbus address can be changed from its default 10.

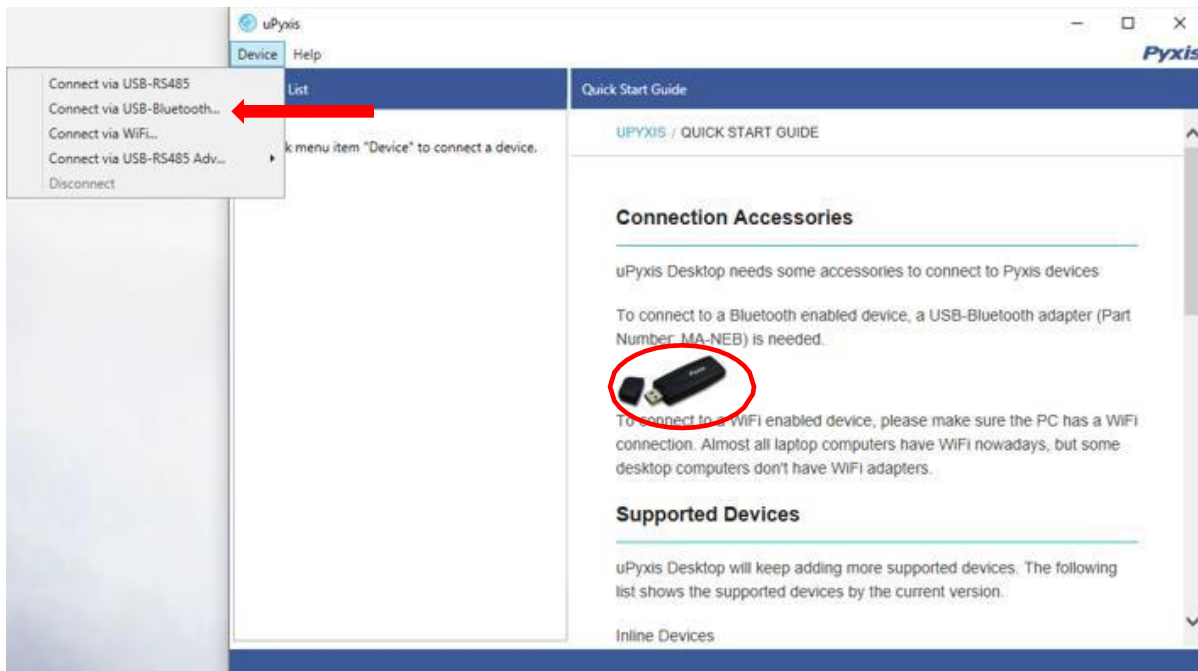

Figure 9. Connection Options

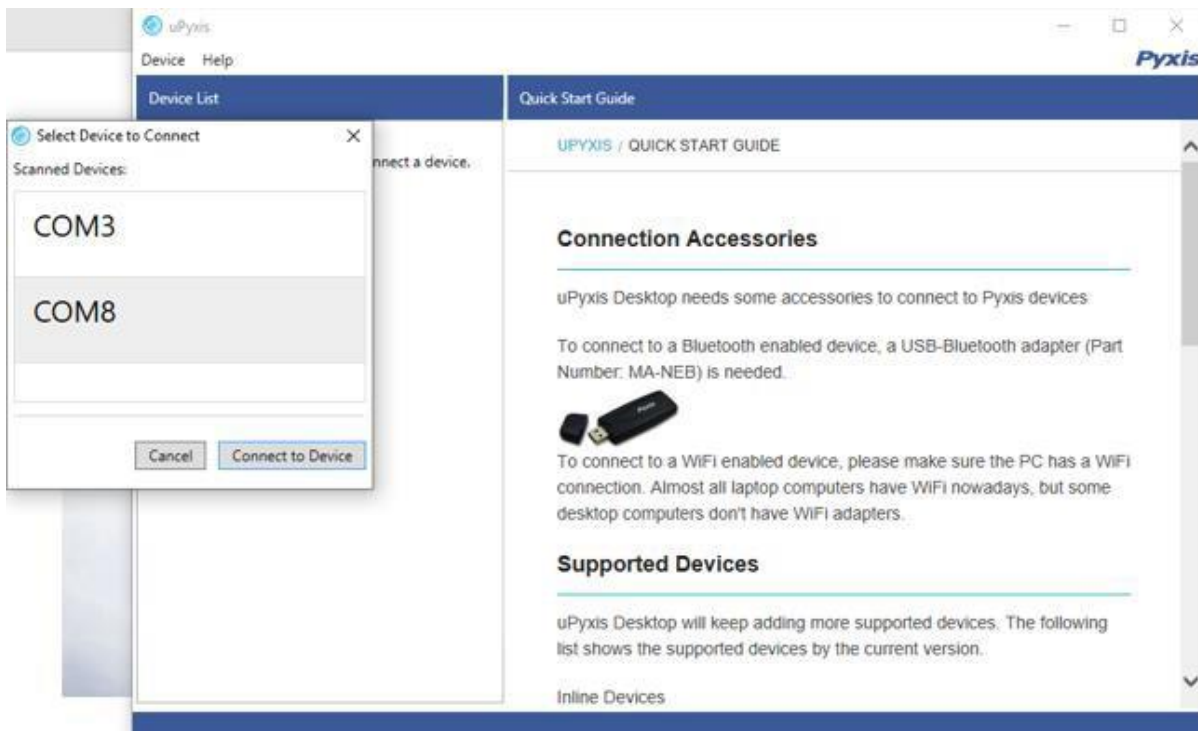

Figure 10. Select a Comm port

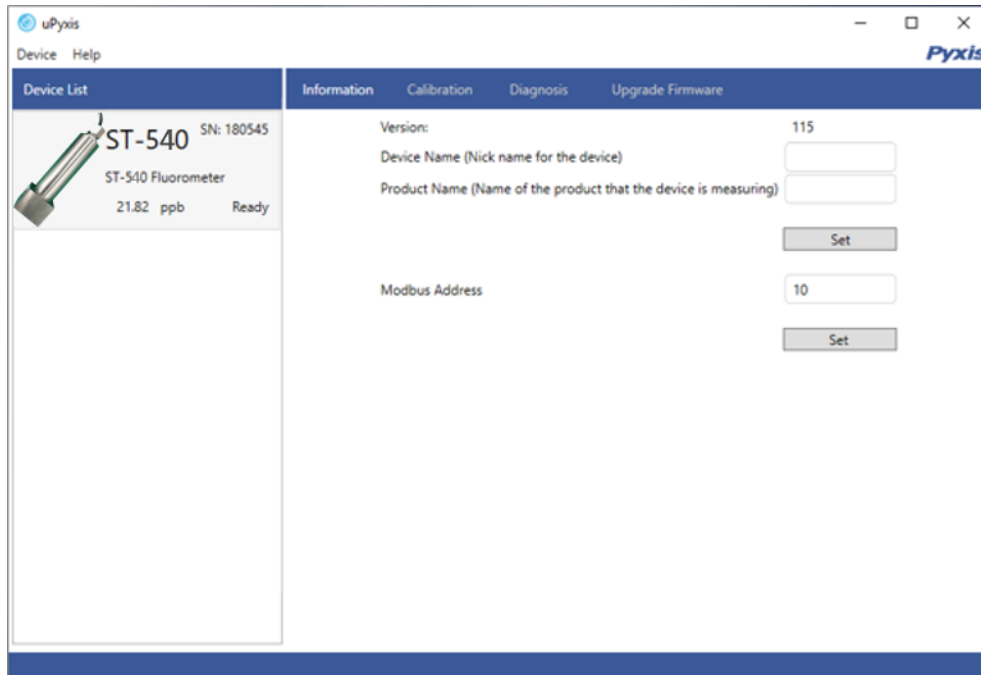

Figure 11. Connected to a ST-540 sensor and information page



Figure 12. Calibration page

4.2.1 Calibration

Click **Calibration** to launch the calibration page (Figure 13). Place the sensor in deionized water and click **Zero Calibration** to carry out the zero-point calibration.

Place the sensor in a NDSA standard and click **Slope Calibration** to carry out the slope calibration. Enter the NDSA concentration in the dialog window as in Figure 14. For the best result, the NDSA standard should be in the range of 100 ppb for the ST-540SS and ST-540A, and 10ppb for the ST-540SS-N.

4.2.2 4-20mA Span Settings

The default 4-20mA span is 20 mA = 500 ppb and 4 mA = 0 ppb NDSA. Click **4-20mA Span** to change the NDSA value corresponding to the 20mA output (Figure 15).

4.2.3 Diagnosis

Click **Diagnosis** to the diagnosis page (Figures 16 and 17). In the diagnosis page, the raw data measured by the sensor is displayed. To help troubleshoot possible issues with the sensor, please save an image of this data when the sensor is placed in a clean water (tap water or deionized water), in a standard, and in the sample that the sensor is intended.

In the diagnosis page, the sensor cleanliness check can be performed. Please place the sensor in a NDSA standard or other water samples available and select the sample condition by click **Diagnosis Condition**. Click **Cleanliness Check** to carry out the check. If the sensor is clean, a green **Clean** message will be shown. If the sensor is severely fouled, a red **Dirty** message will be shown. In this case, please clean the sensor according to the procedure in Section 6 of this manual. If the sensor is partially fouled, a yellow **Becoming Dirty** message tab will be shown.

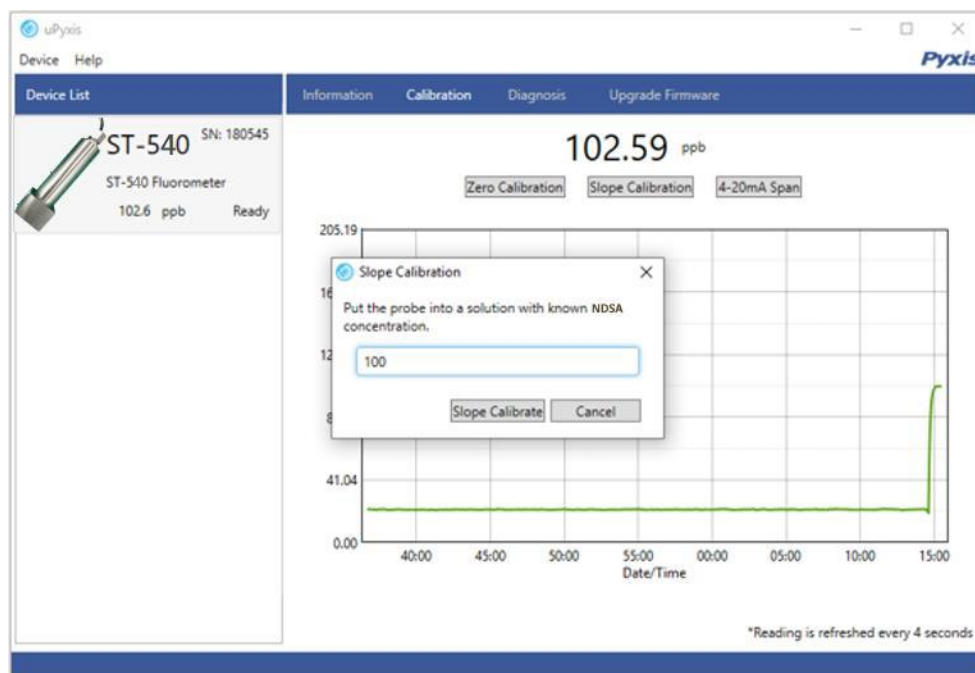

Figure 13. Enter NDSA concentration for slope calibration

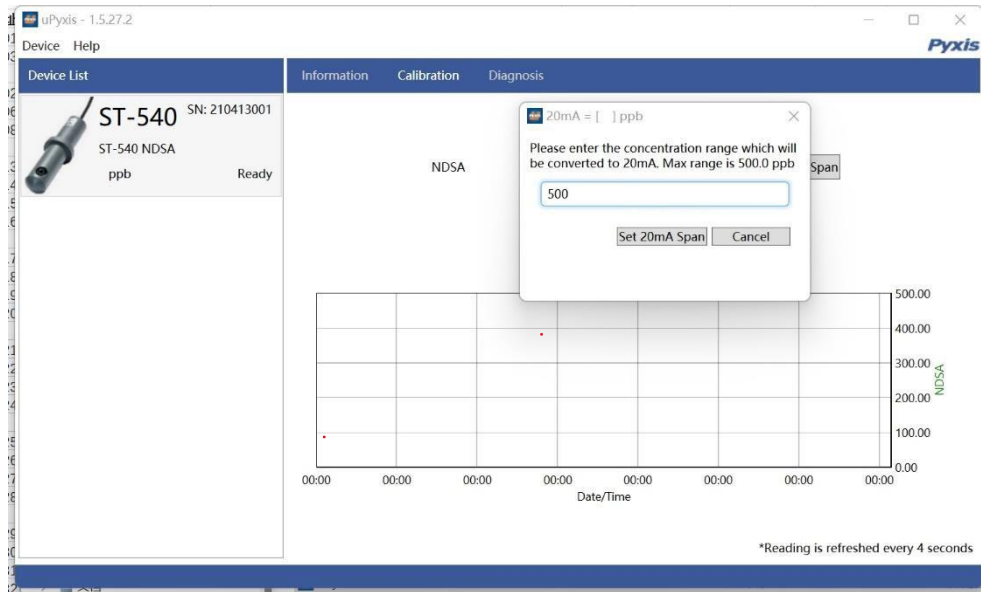

Figure 14. Set 4-20mA span

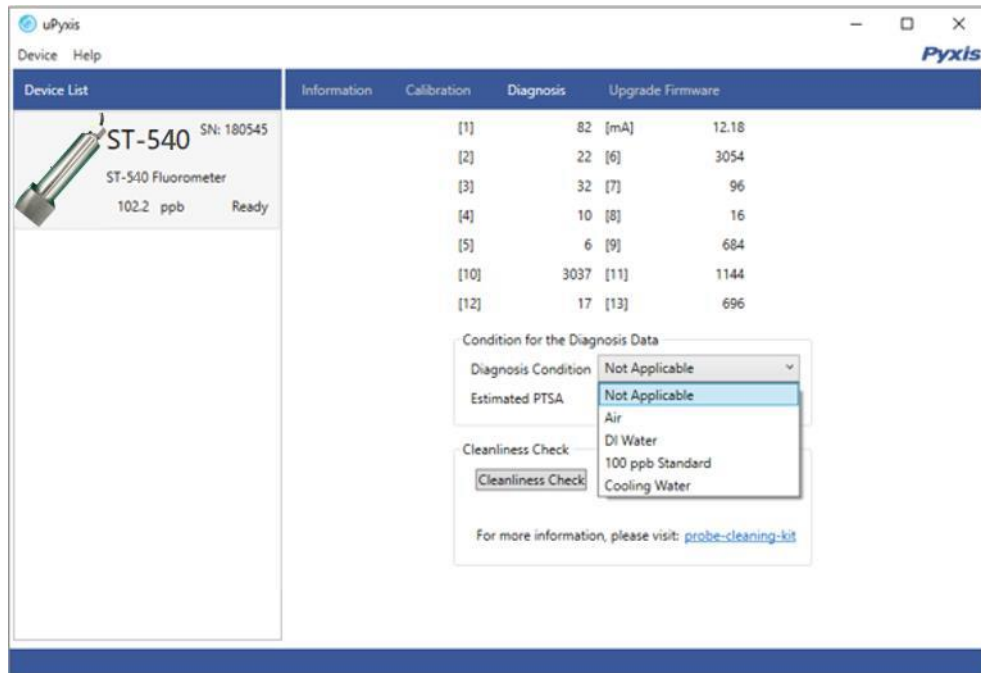

Figure 15. Select diagnosis condition before cleanliness check

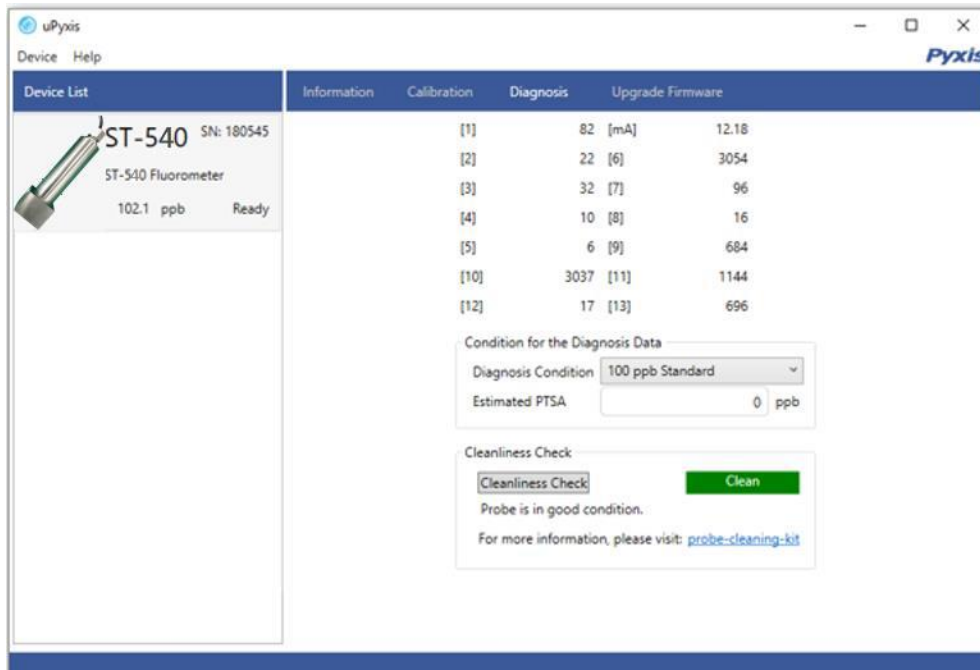

Figure 16. Cleanliness check and raw diagnosis data

4.3 Calibration through the Controller

It is recommended that ST-540 series calibration is carried out using uPyxis app as demonstrated in the sections above. Alternatively, a single point calibration can be carried on the controller by adjusting the mA-to-ppb ratio. A two-point calibration could also be carried out on the controller by adjusting both the mA-to-ppb ratio and the zero-point 4-20mA current value. Please follow the controller manufacturer’s procedure to carry the 4-20mA calibration. With the default sensor settings, the controller should be set up to convert 4 mA to 0 ppb and 20 mA to 500 ppb. It is likewise essential that the ST-540 series sensor be properly and thoroughly cleaned prior to calibrating via the controller. Calibration of a fouled sensor via the controller may result in scaling issues that can make future calibrations more challenging.

For the single calibration involving the water sample itself, please determine the NDSA concentration in the sample by using the Pyxis SP-395N (or similar offline fluorometer) or calculated from the concentration of any measurable species in the sample water such as polymer, phosphate, or molybdate.

5 Modbus RTU

The ST-540 series sensor is configured as a Modbus slave device. In addition to the ppb NDSA value, many operational parameters, including warning and error messages, are available via a Modbus RTU connection.

Contact Pyxis Lab Customer Service (service@pyxis-lab.com) for more information.

6 Sensor Cleaning and Maintenance

The ST-540 series sensor is designed to provide reliable and continuous NDSA readings even when installed in moderately contaminated industrial waters. Although the optics are compensated for the effects of moderate fouling, heavy fouling will prevent the light from reaching the sensor, resulting in low readings and the potential for product overfeed if the ST-540 series is used as part of an automated control system. When used to control product dosing, it is suggested that the automation system be configured to provide backup to limit potential product overfeed, for example by limiting pump size or duration, or by alarming if the pumping rate exceeds a desired maximum limit.

The ST-540 series sensor is designed to be easily removed, inspected, and cleaned if required. It is suggested that the ST-540 series sensor be checked for fouling and cleaned/calibrated on a monthly basis. Heavily contaminated waters may require more frequent cleanings. Cleaner water sources with less contamination may not require cleaning for several months.

The need to clean the ST-540 series sensor can be determined by the Cleanliness Check using uPyxis App as described in the above sections.

6.1 Cleaning Procedure

A light deposit inside the sensor quartz tube can be cleaned by a nylon pipe cleaner and Q-tip. Aged heavy deposition, especially iron oxide deposited, can be removed using a cleaning solution that is capable of removing iron, such as the Pyxis Probe Cleaning Solution Kit (part # SER-01) available from Pyxis online Estore/Catalog <https://www.pyxis-lab.com/product/inline-sensor-cleaning-kit/>

Soak the lower half of the ST-540 series sensor in 100 ml inline sensor cleaning solution for 15-30 minutes depending on the degree of fouling. Gently clean with nylon pipe cleaner or Q-tip provided, then rinse the ST-540 series sensor with distilled water and then check for the flashing blue light inside the ST-540 series sensor quartz tube. If the surface is not entirely clean, continue to soak the ST-540 series sensor for an additional 15-30 minutes. The diagnosis function in uPyxis app in a phone or a PC can be used to check Cleanliness of the sensor before and after cleaning as described in Section 4 of this manual.

Cleaning Solution Kit



Figure 17. Pyxis Probe

6.2 Other Common Troubleshooting Issues

If the ST-540 series sensor output signal is not stable and fluctuates significantly, make an additional solution ground connection - connect the clear solution ground wire to a conductor that contacts the sample water electrically such as a brass pipe adjacent to the ST-540 series sensor.

Contact us

Contact us if you have questions about the use or maintenance of the ST-540 sensor:

Pyxis Lab, Inc.

1729 Majestic Dr. Suite 5

Lafayette, CO 80026 USA

1-866-203-8397

www.pyxis-lab.com

service@pyxis-lab.com