

# Pyxis<sup>®</sup>

## **'Direct Insert' PTSA Sensor for Walchem<sup>®</sup> & Turner Designs<sup>®</sup> Tees** *for Industrial Cooling Water Applications*



**Pyxis Lab<sup>®</sup> Inc.**

1729 Majestic Dr. (Suite 5)  
Lafayette, CO 80026  
[www.pyxis-lab.com](http://www.pyxis-lab.com)

**USER MANUAL**

## Table of Contents

<b>1</b>	<b>Introduction</b> .....	<b>2</b>
<b>2</b>	<b>Specifications</b> .....	<b>3</b>
<b>3</b>	<b>Unpacking Instrument</b> .....	<b>3</b>
3.1	Standard Accessories Included with ST-500W.....	4
3.2	Optional Accessories.....	4
	<b>Optional Accessories Information</b> .....	<b>4</b>
<b>4</b>	<b>Installation &amp; Diagram</b> .....	<b>5</b>
4.1	ST-500W Installation Instructions & Diagram.....	5
4.2	Wiring.....	7
4.3	Connecting via Bluetooth to Mobile Device .....	7
<b>5</b>	<b>Setup and Calibration with uPyxis® Mobile App</b> .....	<b>8</b>
5.1	Download uPyxis® Mobile App .....	8
5.2	Connecting to uPyxis® Mobile App .....	9
5.3	Calibration Screen and Reading .....	9
5.4	Diagnosis Screen .....	10
5.5	Device Info Screen .....	11
<b>6</b>	<b>Setup and Calibration with uPyxis® Desktop App</b> .....	<b>11</b>
6.1	Install uPyxis® Desktop App .....	11
6.2	Connecting to uPyxis® Desktop App via Bluetooth.....	12
6.3	Connecting to uPyxis® Desktop App via USB-C Cable.....	13
6.4	Information Screen .....	15
6.5	Calibration Screen.....	15
6.6	Diagnosis Screen .....	16
<b>7</b>	<b>Outputs</b> .....	<b>16</b>
7.1	4–20mA Output Setup .....	16
7.2	Adjusting 4–20mA Span .....	17
7.3	Communication using Modbus RTU .....	18
<b>8</b>	<b>Sensor Maintenance and Precaution</b> .....	<b>18</b>
8.1	Methods to Cleaning the ST-500 Series Sensor .....	19
8.2	Storage .....	19
<b>9</b>	<b>Troubleshooting</b> .....	<b>20</b>
<b>10</b>	<b>Contact Us</b> .....	<b>20</b>

## **Warranty Information**

### **Confidentiality**

The information contained in this manual may be confidential and proprietary and is the property of Pyxis Lab, Inc. Information disclosed herein shall not be used to manufacture, construct, or otherwise reproduce the goods described. Information disclosed herein shall not be disclosed to others or made public in any manner without the express written consent of Pyxis Lab, Inc.

### **Standard Limited Warranty**

Pyxis Lab warrants its products for defects in materials and workmanship. Pyxis Lab will, at its option, repair or replace instrument components that prove to be defective with new or remanufactured components (i.e., equivalent to new). The warranty set forth is exclusive and no other warranty, whether written or oral, is expressed or implied.

### **Warranty Term**

The Pyxis warranty term is thirteen (13) months ex-works. In no event shall the standard limited warranty coverage extend beyond thirteen (13) months from original shipment date.

### **Warranty Service**

Damaged or dysfunctional instruments may be returned to Pyxis for repair or replacement. In some instances, replacement instruments may be available for short duration loan or lease.

Pyxis warrants that any labor services provided shall conform to the reasonable standards of technical competency and performance effective at the time of delivery. All service interventions are to be reviewed and authorized as correct and complete at the completion of the service by a customer representative, or designate. Pyxis warrants these services for 30 days after the authorization and will correct any qualifying deficiency in labor provided that the labor service deficiency is exactly related to the originating event. No other remedy, other than the provision of labor services, may be applicable.

Repair components (parts and materials), but not consumables, provided during a repair, or purchased individually, are warranted for 90 days ex-works for materials and workmanship. In no event will the incorporation of a warranted repair component into an instrument extend the whole instrument's warranty beyond its original term.

### **Warranty Shipping**

A Repair Authorization (RA) Number must be obtained from Pyxis Technical Support before any product can be returned to the factory. Pyxis will pay freight charges to ship replacement or repaired products to the customer. The customer shall pay freight charges for returning products to Pyxis. Any product returned to the factory without an RA number will be returned to the customer. To receive an RMA you can generate a request on our website at <https://pyxis-lab.com/request-tech-support/>

### **Pyxis Technical Support**

Contact Pyxis Technical Support at +1 (866) 203-8397, [service@pyxis-lab.com](mailto:service@pyxis-lab.com), or by filling out a request for support at <https://pyxis-lab.com/request-tech-support/>.

## 1 Introduction

The ST-500W is a stainless steel inline PTSA Pyxis smart sensor uniquely designed to be directly inserted into the Walchem® and alternative fluorometer tee assemblies. Since the alternative fluorometers commonly used in the water treatment industry have very similar dimensions as the Walchem tee design, the ST-500W design allows drop-in installation into both designs of inline tee assemblies without the need for plumbing modifications of equipment already in use.

The ST-500W is identical in internal design and function as the world-class ST-500 Series inline PTSA sensor platform offering the industry a proprietary design for the direct measurement of PTSA (Pyrenetetrasulfonic Acid, CAS# 59572-10-0) utilizing LED UV light sources (365nm ex/ 410nm em) and is specifically designed for use in industrial cooling water and process water treatment applications.

The Pyxis ST-500W sensor is a smart device. In addition to measuring fluorescence, all ST-500 Series sensors have extra photo-electric components that monitor the color and turbidity of the sample water. This extra feature allows automatic color and turbidity compensation to eliminate interference commonly associated with real-world waters. The ST-500W offers a combination of 4-20mA as well as RS-485 Modbus output signals in 8-Pin cable format and is Bluetooth Enabled for wireless cleanliness diagnostics and calibration when used with MA-CR or PowerPACK Series Bluetooth Adapters and the uPyxis APP for Mobile or Desktop devices. The ST-500W comes equipped with 1.5m (4.9ft) bulk-head cable with quick adapter as well as 1.5m (4.9ft) flying lead cable with quick adapter, enabling rapid wiring to any microprocessor controller, PLC or DCS system.

The Pyxis ST-500W sensor has a short fluidic channel and can be easily cleaned. The fluidic and optical arrangement of the ST-500W is designed to overcome shortcomings associated with other fluorometers that have a distal sensor surface or a long, narrow fluidic cell. Traditional inline fluorometers are susceptible to color, turbidity interference, and fouling, making them very difficult to properly clean.

The Pyxis ST-500W sensor uses a narrow wavelength band gallium phosphide photodiode and high temperature-tolerant and humidity-resistant optical filters. This combination greatly enhances the robustness of the sensor. It can be operated under a wide range of ambient conditions without the need of humidity and temperature regulation. The performance of the ST-500W sensor can be stable and consistent for a long period of time.



ST-500W Sensor

## 2 Specifications

**Table 1.** ST-500W Specifications

Item	ST-500W
P/N	58802
PTSA Output Range <i>Factory Set Range</i>	0 – 200ppb
PTSA Maximum Range <i>Adjusted via uPyxis</i>	0 - 300ppb
PTSA Precision/Accuracy	+/- 1 ppb
Excitation/Emission	LED 365/410nm
Power Supply	22 – 26V DC, Power Consumption – 1W
Outputs	Isolated 4 – 20 mA Analog Outputs & RS-485 Modbus Output -8Pin
Installation	Walchem® Inline Tee ( <i>pH &amp; Conductivity</i> ) Alternative Fluorometer Inline Tee
Miscellaneous Items Included	1-Universal Nut / 1-Oring for Walchem Tee / 1-Oring for Alternative Fluorometer Tee
Flow Range	0.25 – 8.0 GPM
Weight	500 g (1.1 lbs)
Operational Pressure	≤100 psi (6.9 Bar)
Operating Temperature	4 °C – 49 °C (40 – 120 °F)
Storage Temperature	-20 °C – 60 °C (-4 – 140 °F)
Material	304 Stainless Steel
Rating	IP67, Fully Dustproof & Waterproof
Regulation	CE Marked + RoHS
Dimension (L x W x H)	Length 6.8 inch (172.7 mm), body diameter 1.44 Inch (36.6 mm)
Cable Length	1.5 meter 8-pin Bulkhead w Adapter/ 1.5 meter 8-pin Flying Lead w/ Adapter

**NOTE** - These specifications are subject to change without notice.

Walchem® is a registered trademark of Iwaki America Inc. – Holliston, MA.

## 3 Unpacking Instrument

Remove the instrument and accessories from the shipping container and inspect each item for any damage that may have occurred during shipping. Verify that all accessory items are included. If any item is missing or damaged, please contact Pyxis Lab Customer Service at [service@pyxis-lab.com](mailto:service@pyxis-lab.com).

### 3.1 Standard Accessories Included with ST-500W

Each ST-500W Package (P/N 58802) will include the following standard accessories.

- One ST-500W Inline PTSA Sensor
- One Universal NUT (P/N 23133) for sensor install with Walchem -or- Alternative Fluorometer Tee Assemblies
- One O-ring for sensor use with the Walchem Tee (P/N 21501)
- One O-ring for sensor use with the Alternative Fluorometer Tee (P/N 26560)
- One Quick-Start Instruction Guide with QR Code to Operation Manual

User Manual also available online at [www.pyxis-lab.com](http://www.pyxis-lab.com)



**Figure 1. – ST500W Package As Opened**

### 3.2 Optional Accessories

#### Optional Accessories Information

#### P/N

Universal Nut Replacement ( <i>ST-500W Nut for use with Walchem or Alternative Tee Assembly</i> )	23133
O-ring Replacement ( <i>for ST-500W use with Walchem Tee</i> )	21501
O-ring Replacement ( <i>for ST-500W use with Alternative Fluorometer Tee</i> )	26560
PTSA-100 ( <i>PTSA Calibration Standard 100ppb / 500mL</i> )	21001
Pyxis Probe Cleaning Kit ( <i>500mL Cleaning Solution with Brushes</i> )	SER-01
MA-CR Bluetooth Adapter ( <i>Pyxis Bluetooth Adapter for 8Pin Pyxis Sensors</i> )	MA-CR
MA-NEB Bluetooth/USB Adapter ( <i>Enables Bluetooth for Desktop and uPyxis APP</i> )	MA-NEB
PowerPACK-1 ( <i>Single Chanel Auxiliary Power Supply w/Bluetooth For Pyxis Sensors</i> )	MA-BLE-1
PowerPACK-2 ( <i>Dual Chanel Auxiliary Power Supply w/Bluetooth For Pyxis Sensors</i> )	MA-BLE-2
PowerPACK-4 ( <i>Four Chanel Auxiliary Power Supply w/Bluetooth For Pyxis Sensors</i> )	MA-BLE-4
MA-NEB Bluetooth/USB Adapter ( <i>Enables Bluetooth for Desktop and uPyxis APP</i> )	MA-NEB
MA-10CR ( <i>10' Extension Cable for 8Pin Pyxis Sensors</i> )	50741
MA-50CR ( <i>50' Extension Cable for 8Pin Pyxis Sensors</i> )	50743

## 4 Installation & Diagram

### 4.1 ST-500W Installation Instructions & Diagram

The ST-500W has been uniquely designed to be used in both the Walchem Tee Assembly or the Alternative Fluorometer Tee Assembly. This approach was taken to enable users the ability to use advanced Pyxis sensor technology without the need for plumbing and/or equipment change of existing systems installed in the field.

Each ST-500W will come provided with the sensor.

- One 8-Pin bulkhead cable
- One 8-Pin flying lead cable
- One Universal NUT (CPVC) for use with both Walchem and Alternative Fluorometer Tee Assembly
- One O-ring for use with Walchem Tee Assembly
- One O-ring for use with Alternative Fluorometer Tee Assembly

The ST-500W can be installed in a vertical or horizontal flow path with the existing Walchem or Alternative Fluorometer Tee in place. When installed in a horizontal flow path, a downstream valve is always suggested to allow users to mitigate any potential for air bubble interference. The following steps should be taken for installation.

1. Determine if your existing inline Tee assembly is Walchem or Alternative Fluorometer. Typically, the Walchem tee is a light gray CPVC material while the Alternative Fluorometer tee is a dark grey or black CPVC material.
2. Once your tee is identified, insert the appropriately labeled O-ring provided with the ST-500W based on the manufacturer of your tee (ie. Walchem or Alternative Fluorometer). Insert the O-ring into the O-ring groove of the tee. You will note varying O-ring thickness is used for each tee design. Using the incorrect O-ring can lead to a non-water tight seal.
3. Insert the ST-500W sensor into the tee with the stainless-steel collar alignment screws properly aligned with the tee.
4. Tighten the Pyxis provided Universal Nut onto the tee to form a water-tight, compression seal.
5. **NOTE** – *This nut is universally designed to be used on both the Walchem and Alternative Fluorometer Designs tee assemblies and should always be used with the correct O-ring provided by Pyxis Lab. Some tee threads may remain visible even if the nut is fully engaged onto the tee. This is normal and should not be for concern and the nut will function as specified for pressure and flow of the ST-500W sensor specifications. Replacement NUT and O-rings are available from Pyxis Lab Inc.*



Figure 2. ST-500W Installed into Walchem Tee

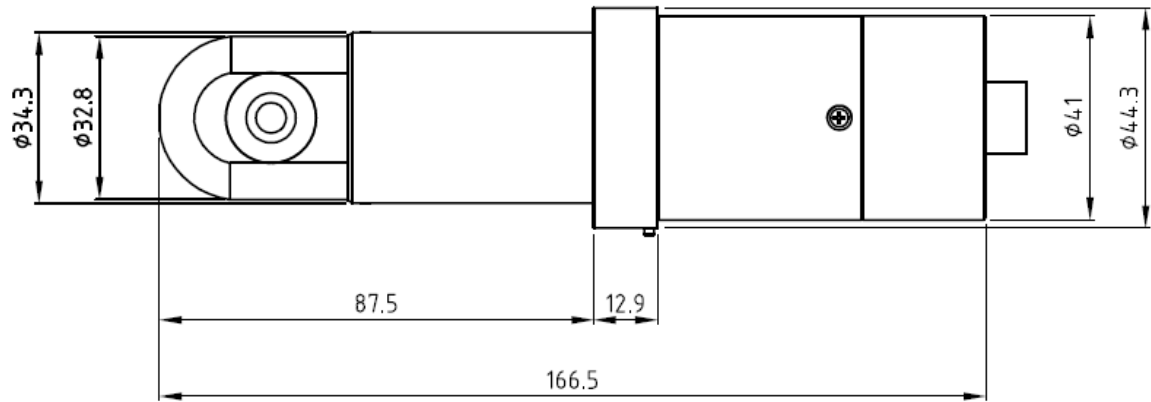

Figure 3. Dimension of the ST-500W Sensor

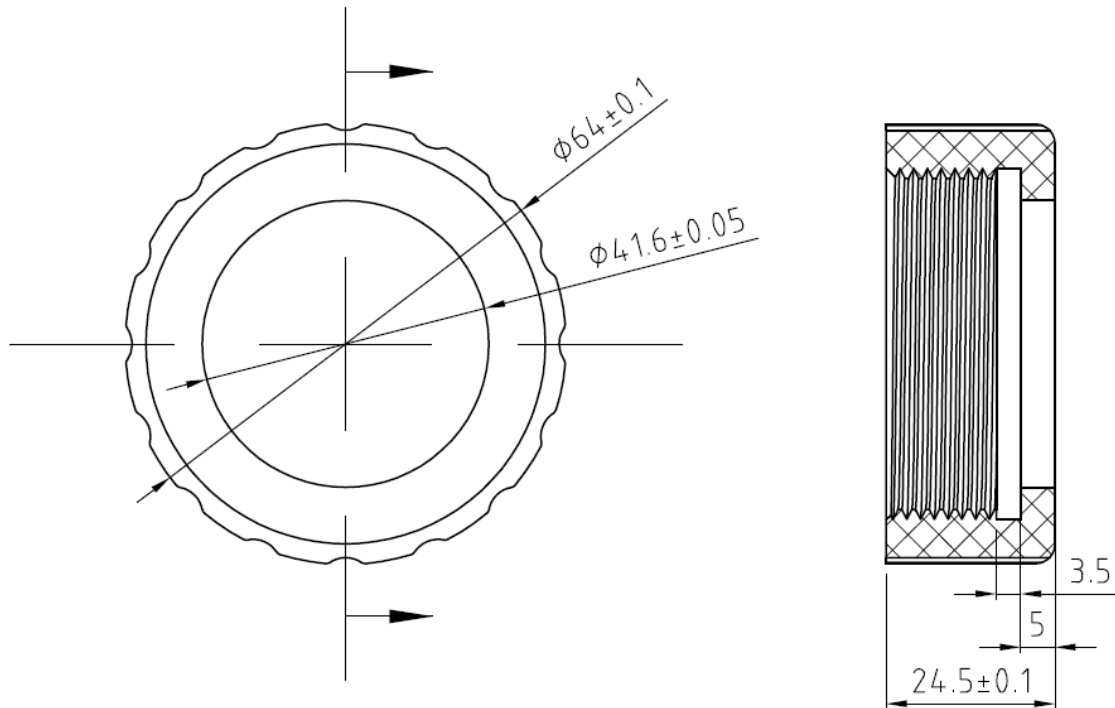

Figure 4 . Dimension of the ST-500W Universal NUT Tee Assembly (mm)

## 4.2 Wiring

Please refer to the table below for wiring of the ST-500W to a receiving controller or PLC.

**\*NOTE\***: *The 24V power ground and the 4-20 mA- return are internally connected. If insufficient wattage is available from the connected controller (ie. 1.5W), Pyxis recommends the **PowerPACK Series** Auxiliary Power & Bluetooth Communication Adapters highlighted in the Optional Accessories section of this manual. If a separate DC power supply other than that from the controller is used, make sure that the output from the power supply is rated for 22-26 VDC @ 65mA. Detailed wiring diagrams for common controllers are available from [www.pyxis-lab.com](http://www.pyxis-lab.com).*

Figure 5.

Wire Color	Designation
Red	24V +
Brown	24V Power ground
White	4–20mA + PTSA
Grey	4-20mA -
Pink	Not Used
Green*	Earth Ground
Blue	RS-485 A
Yellow	RS-485 B
Black	Shield, Earth ground

Please refer to the table below for proper ST-500W input 4-20mA scaling in your receiving display, controller or PLC.

Figure 6.

ST-500W Output Scaling (4-20mA)		
mA	Value	Units
4	0	ppb
20	200	ppb

**\*NOTE\*** *the 20mA value is adjustable to a MAX of 300ppb via uPyxis. See 4-20mA SPAN Adjustment in this manual for details. For values >300ppb, Pyxis must do a factory scale adjustment.*

## 4.3 Connecting via Bluetooth to Mobile Device

A Bluetooth adapter (P/N: MA-CR) can be used to connect a ST-500 Series sensor to a smart phone or mobile device with the **uPyxis®** Mobile App directly. The power should be sourced from a 24VDC power terminal of a controller. If a controller is not available, please purchase a Pyxis **PowerPACK Series** auxiliary power supply with Bluetooth (see Section 3.2), or an alternative 24VDC power supply that can directly connect to the ST-500 Series sensor with proper cable connectors from Pyxis.

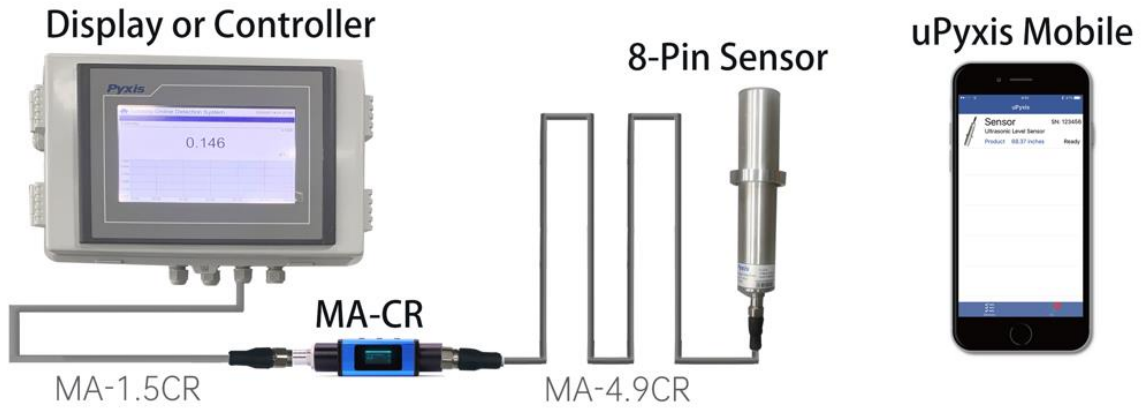

Figure 7. 8-Pin Pyxis Sensor with MA-CR and uPyxis Mobile APP

## 5 Setup and Calibration with uPyxis® Mobile App

### 5.1 Download uPyxis® Mobile App

Download uPyxis® Mobile App from [Apple App Store](#) or [Google Play](#).



Figure 8. uPyxis® Mobile APP Installation

## 5.2 Connecting to uPyxis® Mobile App

Connect the ST-500 Series sensor to a mobile smart phone according to the following steps:

1. Install the MA-CR Bluetooth Adapter on the 8Pin output cable from the ST-500W as outlined on page 8 as seen in **Figure 7** (if powered by a controller).
2. Open the **uPyxis®** Mobile App.
3. In the **uPyxis®** Mobile App, swipe down with finger on the main screen to refresh the list of available Pyxis devices.  
*\*NOTE\* this may take multiple finger swipes for Bluetooth to connect to the device.*
4. If the connection is successful, the Prism ST-500W and its Serial Number (S/N) will be displayed (Figure 9).
5. Press on the **ST-500W sensor image**.

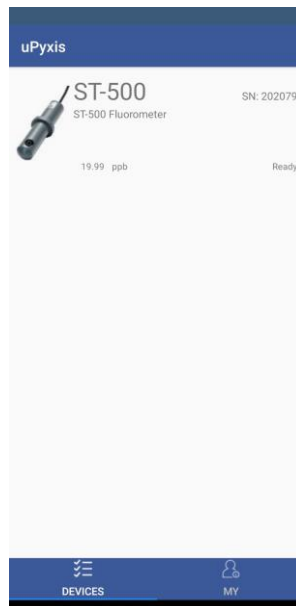

Figure 9.

## 5.3 Calibration Screen and Reading

When connected, the **uPyxis®** Mobile App will default to the **Calibration** screen. From the **Calibration** screen, you can perform calibrations by pressing on **Zero Calibration**, **Slope Calibration**, and **4-20mA Span**. Follow the screen instructions for each calibration step.



Figure 10.

### 5.4 Diagnosis Screen

From the **Diagnosis** screen, you can check the diagnosis condition as well as **Export & Upload**. This feature may be used for technical support when communicating with [service@pyxis-lab.com](mailto:service@pyxis-lab.com)

To perform a Cleanliness Check, first select the **Diagnosis Condition** which defines the fluid type that the ST-500 Series sensor is currently measuring, then press **Cleanliness Check**. If the sensor is clean, a **Clean** message will be shown. If the sensor is severely fouled, a **Dirty** message will be shown. In this case, follow the procedure in the **Methods to Cleaning the ST-500 Series Sensor** section of this manual.

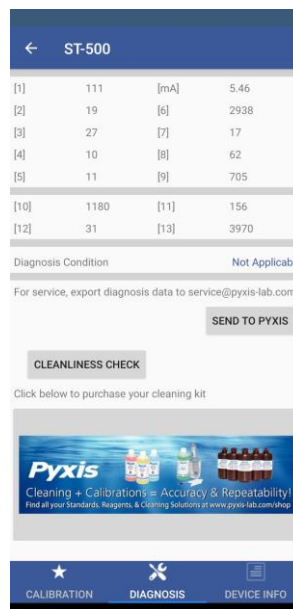

Figure 11.

## 5.5 Device Info Screen

From the **Device Info** screen. You can name the Device or Product as well as reassign Modbus register.

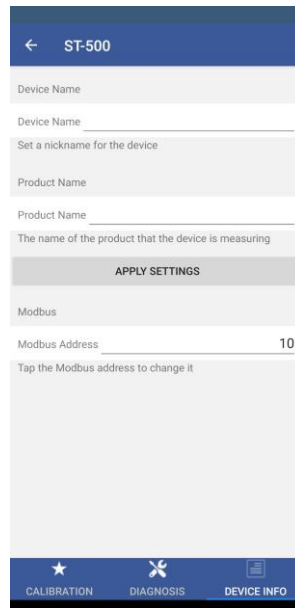

Figure 12.

## 6 Setup and Calibration with uPyxis® Desktop App

### 6.1 Install uPyxis® Desktop App

Download and install uPyxis Desktop APP on your PC or Laptop from <https://upyxis.pyxis-lab.com.cn/release/pc/uPyxis.Setup-latest.zip>

Click **Install** to start the installation process. Follow the screen instructions to complete the USB driver and **uPyxis®** installation.

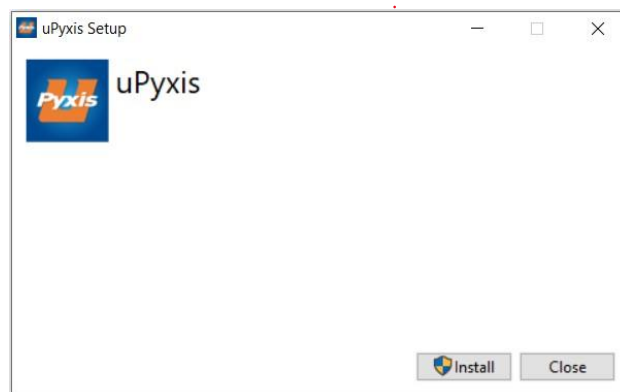
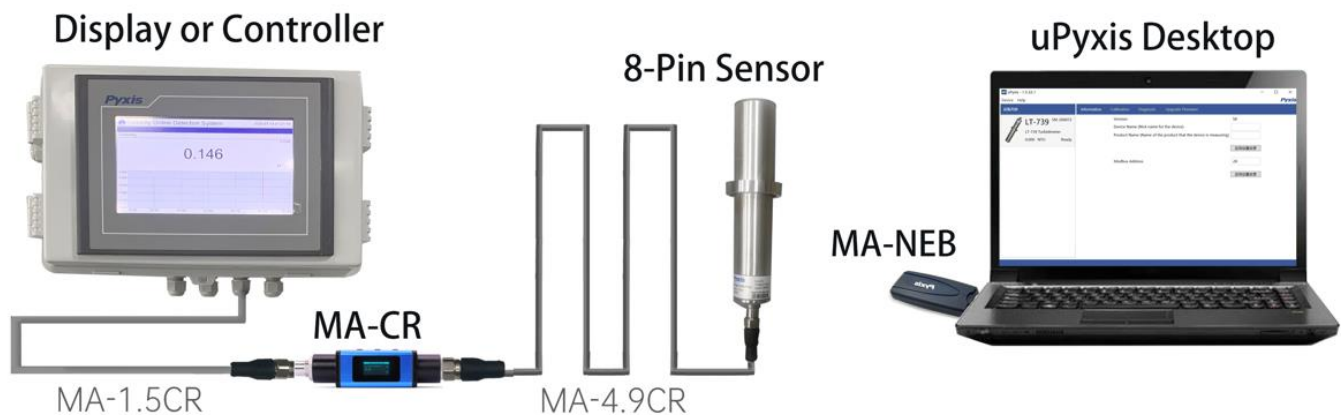

Figure 13. uPyxis® Desktop App installation

## 6.2 Connecting to uPyxis® Desktop App via Bluetooth

A Bluetooth adapter (P/N: MA-CR) can be used to connect a ST-500 Series sensor to a laptop or a desktop computer with a Bluetooth/USB Adapter (P/N: MA-NEB) and the **uPyxis®** Desktop App. The power should be sourced from a 24VDC power terminal of a controller. If a controller is not available, please purchase a Pyxis **PowerPACK Series** auxiliary power supply with Bluetooth (see Section 3.2), or an alternative 24VDC power supply that can directly connect to the ST-500 Series sensor with proper cable connectors from Pyxis.



**Figure 14.** 8-Pin Sensor with MA-CR and MA-NEB and uPyxis Desktop

Connect the ST-500W sensor to a Windows computer using a Bluetooth/USB adapter (P/N: MA-NEB) installed into the PC being used and the MA-CR Bluetooth Adapter (P/N: MA-CR) installed on the 8-Pin output cable of the ST-500W according to the following steps:

1. Install the MA-CR Bluetooth Adapter on the 8Pin output cable from the ST-500W as outlined on page 11 as seen in **Figure 14** (if powered by a controller).
2. Plug the MA-NEB Bluetooth/USB adapter into a USB port of the PC.
3. Launch the **uPyxis®** Desktop App on the PC.
4. On **uPyxis®** Desktop App, click Device → **Connect via USB-Bluetooth** (Figure 15).
5. If the connection is successful, the ST-500W and its Serial Number (S/N) will be displayed in the left pane of the **uPyxis®** window. **\*NOTE\*** After the sensor and Bluetooth is powered up, it may take up to 10 seconds for the adapter to establish the wireless signal for communication.



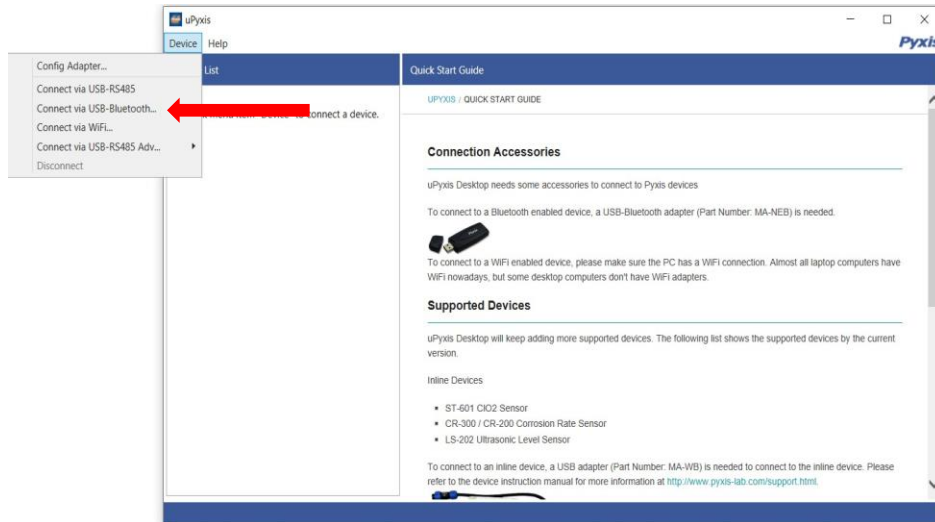

Figure 15.

### 6.3 Connecting to uPyxis® Desktop App via USB-C Cable

For those desiring not to use wireless connection to uPyxis, the MA-CR Bluetooth adapter (P/N: MA-CR) can be used to connect a ST-500 Series sensor to a laptop or a desktop computer with a USB-C cable and the **uPyxis®** Desktop App. The power should be sourced from a 24VDC power terminal of a controller. If a controller is not available, please purchase a Pyxis **PowerPACK Series** auxiliary power supply with Bluetooth (see Section 3.2), or an alternative 24VDC power supply that can directly connect to the ST-500 Series sensor with proper cable connectors from Pyxis.

- 1) Download and install uPyxis Desktop APP from <https://upyxis.pyxis-lab.com.cn/release/pc/uPyxis.Setup-latest.zip>
- 2) Connect a USB Type-C cable to the port at the bottom of the MA-CR and to the USB port of the laptop or computer. This will provide power the MA-WB from the laptop/computer. Connect the MA-CR to the ST-500W sensor. The MA-CR Bluetooth adapter will boost the 5V of the regular USB to 24V to power the sensor for use with uPyxis Desktop App.

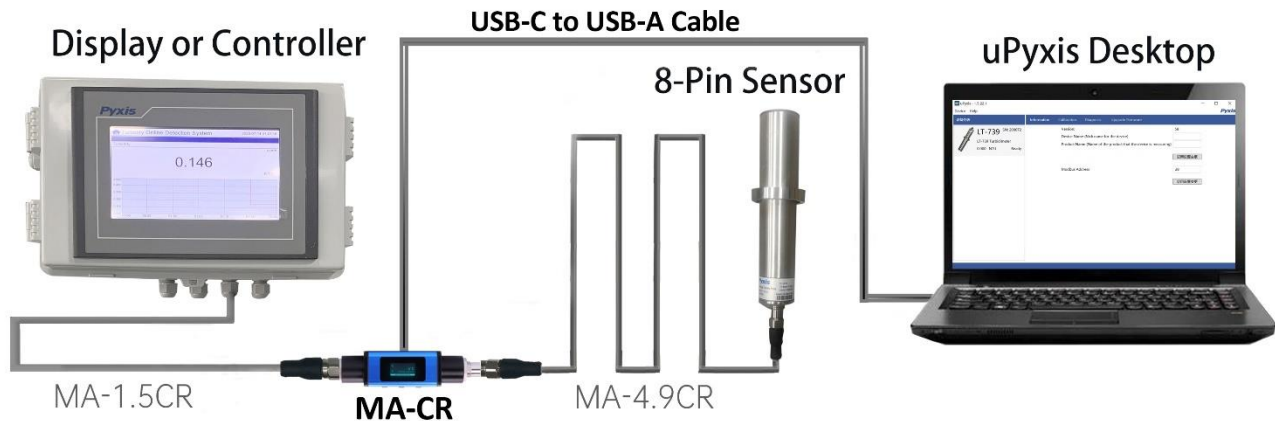
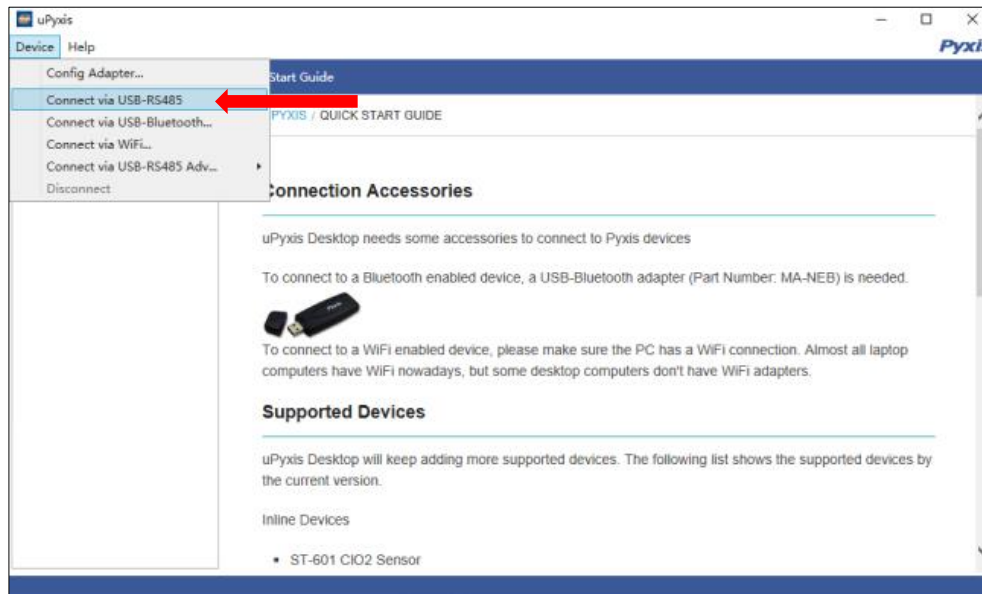

Figure 16.

- 3) Set the MA-CR to operate in USB Mode by following the steps below.
  - a. Once the MA-CR screen is powered Press ◀ or ▶ until you arrive at (USB to RS485) screen.
  - b. Press the **OK** Button.
  - c. Follow Prompts below to Enable USB feature. Once enabled, you may connect to uPyxis.



- 4) Open the desktop uPyxis APP.
- 5) Click Device to launch the connection option menu.
- 6) Select Connect via USB-RS485 (Figure 17).
- 7) Select the Comm Port to make a connection. Normally only one Comm port is identified by uPyxis. If more than one Comm port listed in the selection dropdown, you may try to select each one to see if a connection can be made. Alternatively, you may use the Windows Device Manager to identify the Comm Port that the Pyxis USB adapter is using.



**Figure 17. - Connect to ST-500W via USB-RS485 option**

After the connection is established, the ST-500W probe series number and current PTSA reading are displayed on the left of the information page (Figure 18). In this page, a nickname can be assigned to the probe. The probe Modbus address can be changed in this page.

## 6.4 Information Screen

Once connected to the device, a picture of the device will appear on the top-left corner of the window and the **uPyxis®** Desktop App will default to the **Information** screen. On the **Information** screen you can set the information description for **Device Name**, **Product Name**, and **Modbus Address**, then click **Apply Settings** to save.

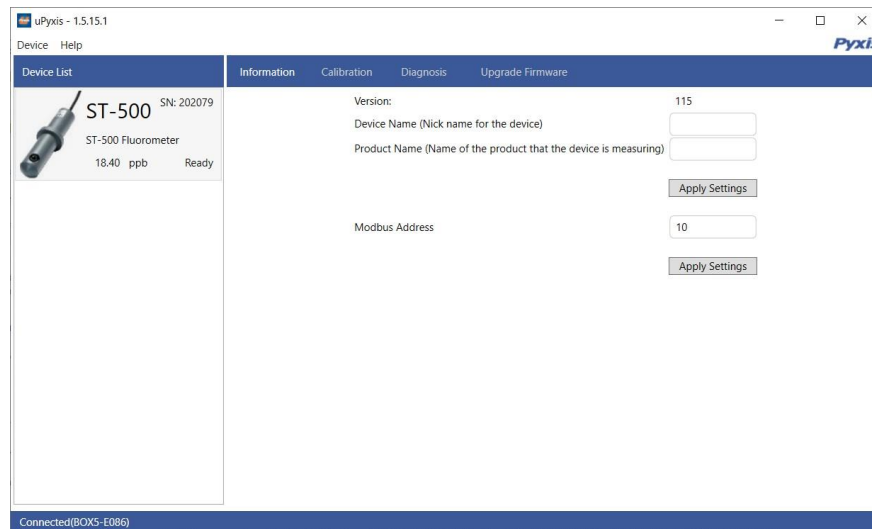

Figure 18.

## 6.5 Calibration Screen

To calibrate the device, click on **Calibration**. On the **Calibration** screen there are three calibration buttons, **Zero Calibration**, **Slope Calibration**, and **4-20mA Span**. The screen also displays the reading of the device. The reading refresh rate is every 4 seconds. Follow the screen instructions for each calibration step.



Figure 19.

## 6.6 Diagnosis Screen

After the device has been calibrated and installation has been completed, to check diagnosis, click on **Diagnosis**. When in the **Diagnosis** screen you can view the Diagnosis Condition of the device. This feature may be used for technical support when communicating with [service@pyxis-lab.com](mailto:service@pyxis-lab.com).

To perform a Cleanliness Check, first select the **Diagnosis Condition** which defines the fluid type that the ST-500 Series sensor is currently measuring, then click **Cleanliness Check**. If the sensor is clean, a green **Clean** message will be shown. If the sensor is severely fouled, a red **Dirty** message will be shown. In this case, follow the procedure in the **Methods to Cleaning the ST-500 Series Sensor** section of this manual.

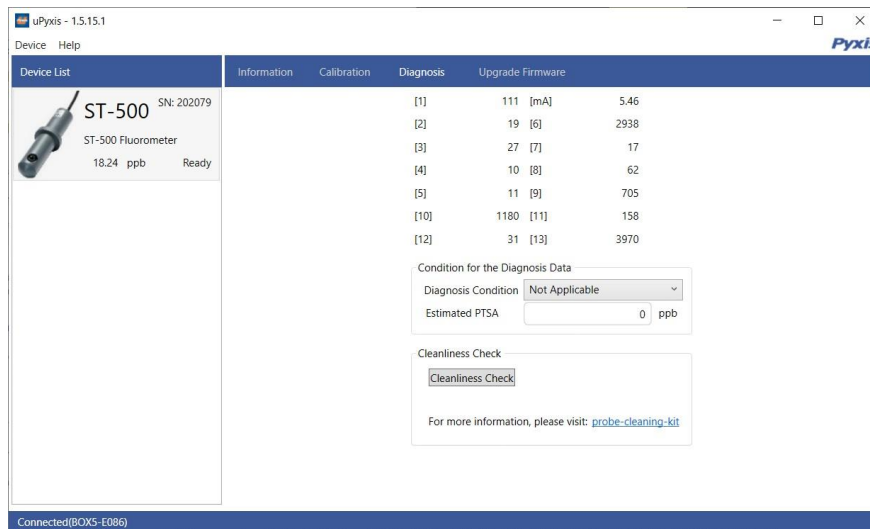

Figure 20.

## 7 Outputs

### 7.1 4–20mA Output Setup

The 4–20mA output of the ST-500W sensor is scaled as:

ST-500W Output Scaling (4-20mA)		
mA	Value	Units
4	0	ppb
20	200	ppb

**\*NOTE\*** the 20mA value is adjustable to a MAX of 300ppb via uPyxis. See 4-20mA SPAN Adjustment in the next section of this manual for details. For values >300ppb, Pyxis must do a factory scale adjustment.

## 7.2 Adjusting 4–20mA Span

Users may adjust the output scale using 4–20mA Span to change the PTSA value corresponding to the 20mA output via uPyxis®. For the uPyxis® Mobile App, press **4-20mA Span** found on the **Calibration and Reading Screen**, shown in Figure 18. For the uPyxis® Desktop App, click **4-20mA Span** found on the **Calibration Screen**, shown in Figure 19. **\*NOTE\*** The ST-500W will allow users to adjust 20mA span to a maximum of 300ppb. For modifications of span to a higher value, the sensor must be formatted at the Pyxis factory. Contact [order@pyxis-lab.com](mailto:order@pyxis-lab.com) for details.

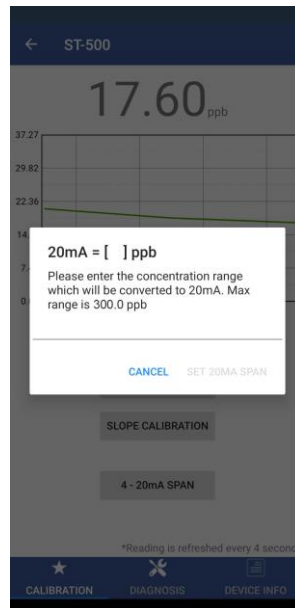

Figure 21.

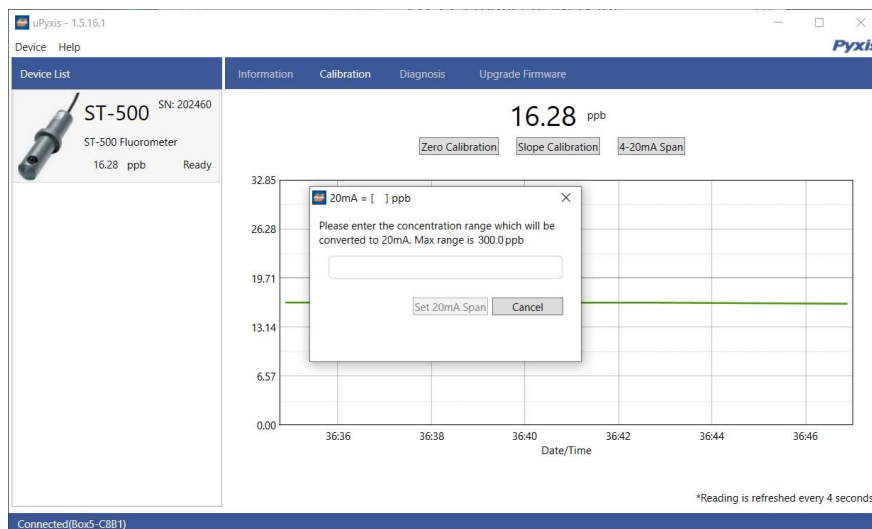

Figure 22.

### 7.3 Communication using Modbus RTU

The ST-500 Series sensor is configured as a Modbus slave device. In addition to the ppb PTSA value, many operational parameters, including warning and error messages, are available via a Modbus RTU connection. Contact Pyxis Lab Customer Service ([service@pyxis-lab.com](mailto:service@pyxis-lab.com)) for more information.

## 8 Sensor Maintenance and Precaution

The ST-500 Series sensor is designed to provide reliable and continuous PTSA readings even when installed in moderately contaminated industrial cooling waters. Although the optics are compensated for the effects of moderate fouling, heavy fouling will prevent the light from reaching the sensor, resulting in low readings and the potential for product overfeed if the ST-500 Series sensor is used as part of an automated control system. When used to control product dosing, it is suggested that the automation system be configured to provide backup to limit potential product overfeed, for example by limiting pump size or duration, or by alarming if the pumping rate exceeds a desired maximum limit.

The ST-500 Series sensor is designed to be easily removed, inspected, and cleaned if required. It is suggested that the ST-500 Series sensor be checked for fouling and cleaned/calibrated on a monthly basis. Heavily contaminated waters may require more frequent cleanings. Cleaner water sources with less contamination may not require cleaning for several months.

The need to clean the ST-500 Series sensor can be determined by the **Cleanliness Check** using either the **uPyxis®** Mobile App (see the **Mobile Diagnosis Screen** section) or the **uPyxis®** Desktop App (see the **Desktop Diagnosis Screen** section).

See Instructional Video on proper cleaning & calibration techniques of the ST-500 series PTSA sensor below.



[How to Clean & Calibrate a Pyxis Lab® ST-Series Inline Sensor | Pyxis Lab® | 2022 Tutorial - YouTube](#)

## 8.1 Methods to Cleaning the ST-500 Series Sensor

Any equipment in contact with industrial cooling systems is subject to many potential foulants and contaminants. Our inline sensor cleaning solutions below have been shown to remove most common foulants and contaminants. A small, soft bristle brush, Q-Tips cotton swab, or soft cloth may be used to safely clean the sensor housing and the quartz optical sensor channel. These components and more come with a Pyxis Lab **Inline Probe Cleaning Solution Kit** (P/N: SER-01) which can be purchased at our online E-Store. <https://www.pyxis-lab.com/product/inline-sensor-cleaning-kit/>



**Figure 23.** Pyxis Inline Probe Cleaning Solution Kit (P/N SER-01)

To clean the ST-500 Series sensor, soak the lower half of the sensor in 100 mL inline sensor cleaning solution for 30 minutes. Rinse the ST-500 Series sensor with distilled water and then check for the flashing blue light inside the ST-500 Series sensor quartz tube. If the surface is not entirely clean, continue to soak the ST-500 Series sensor for an additional 30 minutes. Use the small, soft bristle brush and Q-Tips cotton swabs as necessary to remove any remaining contaminants in the ST-500 Series sensor quartz tube.

## 8.2 Storage

Avoid long term storage at temperature over 140 °F. In an outdoor installation, properly shield the ST-500 Series sensor from direct sunlight and precipitation.

## 9 Troubleshooting

If the ST-500W sensor output signal is not stable and fluctuates significantly, make an additional ground connection — connect the clear (black, earth ground) wire to a conductor that contacts the sample water electrically such as a metal pipe adjacent to the ST-500W installation tee.

Carry out routine calibration verification against a qualified PTSA standard. After properly cleaning the ST500W sensor, carry out the zero point calibration with distilled water and slope calibration using the qualified PTSA standard. Pyxis Lab **PTSA Standards** can be purchased at our online E-Store

<https://www.pyxis-lab.com/product/ptsa-calibration-solutions/>



Figure 24. PTSA-100 Standard

## 10 Contact Us

### Pyxis Lab, Inc

1729 Majestic Dr. Suite 5

Lafayette, CO 80026 USA

[www.pyxis-lab.com](http://www.pyxis-lab.com) Phone: +1

(866) 203-8397

Email: [service@pyxis-lab.com](mailto:service@pyxis-lab.com)