



## ST-500SS-T Series PTSA Sensors

*Stainless Steel PTSA Sensor for High Pressure Industrial Cooling & Process Water Applications*



**Pyxis Lab® Inc.**  
21242 Spell Circle  
Tomball, TX 77375  
[www.pyxis-lab.com](http://www.pyxis-lab.com)

**USER MANUAL**

## Table of Contents

|           |  |           |
|-----------|--|-----------|
| <b>1</b>  | <b>Introduction .....</b>  | <b>2</b>  |
| <b>2.</b> | <b>Specifications.....</b>   | <b>3</b>  |
| <b>3</b>  | <b>Unpacking Instrument.....</b>                                     | <b>4</b>  |
| 3.1       | Standard Accessories .....   | 4         |
| 3.2       | Optional Accessories.....  | 4         |
| <b>4</b>  | <b>Installation .....</b>  | <b>5</b>  |
| 4.1       | ST-500SS-T installed in the ST-009 Stainless Steel Tee Assembly..... | 5         |
| 4.2       | ST-500SS-T Dimension .....   | 6         |
| 4.3       | Wiring.....  | 7         |
| 4.4       | Connecting via Bluetooth to a Mobile Device .....                    | 8         |
| <b>5</b>  | <b>Calibration and Diagnosis with the uPyxis®2.0 Mobile App.....</b> | <b>8</b>  |
| 5.1       | Download and Connect to the uPyxis® 2.0 Mobile App.....              | 9         |
| 5.2       | PTSA Calibration via uPyxis 2.0 Mobile App.....                      | 10        |
| 5.3       | Adjusting the 4-20mA Span via uPyxis 2.0 Mobile App .....            | 11        |
| 5.4       | Diagnosis Screen .....   | 12        |
| <b>6</b>  | <b>Calibration and Diagnosis with the uPyxis® Desktop App .....</b>  | <b>13</b> |
| 6.1       | Download and Connect to the uPyxis Desktop® App.....                 | 13        |
| 6.2       | Information Screen .....   | 15        |
| 6.3       | Calibration Screen.....  | 15        |
| 6.4       | PTSA Calibration via uPyxis Desktop App .....                        | 16        |
| 6.5       | Diagnosis Screen .....   | 17        |
| <b>7</b>  | <b>Outputs.....</b>  | <b>18</b> |
| 7.1       | 4–20mA Output Setup .....  | 18        |
| 7.2       | Adjusting 4–20mA Span via uPyxis Desktop.....                        | 18        |
| 7.3       | Communication using Modbus RTU.....                                  | 18        |
| <b>8</b>  | <b>Sensor Maintenance and Precaution.....</b>                        | <b>19</b> |
| 8.1       | Methods to Cleaning the ST-500SS-T Sensor.....                       | 20        |
| 8.2       | Storage .....  | 20        |
| <b>9</b>  | <b>Troubleshooting .....</b>   | <b>21</b> |
| <b>10</b> | <b>Contact Us .....</b>  | <b>21</b> |

## **Warranty Information**

### **Confidentiality**

The information contained in this manual may be confidential and proprietary and is the property of Pyxis Lab, Inc. Information disclosed herein shall not be used to manufacture, construct, or otherwise reproduce the goods described. Information disclosed herein shall not be disclosed to others or made public in any manner without the express written consent of Pyxis Lab, Inc.

### **Standard Limited Warranty**

Pyxis Lab warrants its products for defects in materials and workmanship. Pyxis Lab will, at its option, repair or replace instrument components that prove to be defective with new or remanufactured components (i.e., equivalent to new). The warranty set forth is exclusive and no other warranty, whether written or oral, is expressed or implied.

### **Warranty Term**

The Pyxis warranty term is thirteen (13) months ex-works. In no event shall the standard limited warranty coverage extend beyond thirteen (13) months from original shipment date.

### **Warranty Service**

Damaged or dysfunctional instruments may be returned to Pyxis for repair or replacement. In some instances, replacement instruments may be available for short duration loan or lease.

Pyxis warrants that any labor services provided shall conform to the reasonable standards of technical competency and performance effective at the time of delivery. All service interventions are to be reviewed and authorized as correct and complete at the completion of the service by a customer representative, or designate. Pyxis warrants these services for 30 days after the authorization and will correct any qualifying deficiency in labor provided that the labor service deficiency is exactly related to the originating event. No other remedy, other than the provision of labor services, may be applicable.

Repair components (parts and materials), but not consumables, provided during a repair, or purchased individually, are warranted for 90 days ex-works for materials and workmanship. In no event will the incorporation of a warranted repair component into an instrument extend the whole instrument's warranty beyond its original term.

### **Warranty Shipping**

A Repair Authorization (RA) Number must be obtained from Pyxis Technical Support before any product can be returned to the factory. Pyxis will pay freight charges to ship replacement or repaired products to the customer. The customer shall pay freight charges for returning products to Pyxis. Any product returned to the factory without an RA number will be returned to the customer. To receive an RMA you can generate a request on our website at <https://pyxis-lab.com/request-tech-support/>.

### **Pyxis Technical Support**

Contact Pyxis Technical Support at +1 (866) 203-8397, [service@pyxis-lab.com](mailto:service@pyxis-lab.com), or by filling out a request for support at <https://pyxis-lab.com/request-tech-support/>.

## 1 Introduction

The Pyxis ST-500SS-T sensors is a new stainless steel design allowing insertion and removal of the sensor into the new Pyxis ST-009 (Stainless Steel) inline tee assembly for high pressure applications up to 290psig. The sensor uses temperature-tolerant and humidity-resistant optical filters that can be operated under a wide range of ambient conditions without the need of humidity and temperature regulation. With this design the performance of the ST-500SS-T series can remain stable and consistent for an extended period time.

The Pyxis ST-500SS-T series sensor measures the concentration of PTSA in water, commonly used as a fluorescent tracer in water treatment applications. This sensor platform is offered in 316L-stainless steel body ideally suited for applications of monitoring cooling or process water applications with elevated operating pressures as high as 290psig. The new design allows for easy sensor removal form the Pyxis ST-009 inline tee assembly for sensor diagnostics, cleaning, and calibration without the need for tools.

The ST-500SS-T is offered in 7-pin cable format and should be used with the Pyxis MA-WB Bluetooth/USB adapter for those desiring to use the uPyxis 2.0 Mobile or Desktop App. The 4–20mA current output from the sensor may be connected to any controller that accepts an isolated or non-isolated 4–20mA input. The ST-500SS-T sensor is a smart device. In addition to measuring fluorescence, the ST-500SS-T sensor has extra photo-electric components that monitor the color and turbidity of the sample water. This extra feature allows automatic color and turbidity compensation to eliminate interference commonly experienced in real-world applications as well as cleanliness diagnostic data.

The ST-500SS-T sensor is offered in a measurement range of 0-500ppb as PTSA and is easy to calibrate using the uPyxis® 2.0 Mobile or Desktop App. Pyxis Lab calibration standard solutions containing PTSA in the range of 100 to 500 ppb can be used for the calibration of the ST-500SS-T. The calibration standard may also be the water sample itself if the PTSA concentration of the sample is measured and validated by a calibrated offline fluorometer. This allows the ST-500SS-T sensor to be calibrated online without being removed from the system. The uPyxis® 2.0 App also provides diagnostic information about the ST-500SS-T sensor such as sensor cleanliness factor which is instrumental in determining if the sensor should be cleaned prior to slope calibration. This diagnostic information can also be available via Modbus RTU. For proper calibration, the ST-500SS-T sensor should be diagnosed for cleanliness via the uPyxis 2.0 APP, then cleaned using the Pyxis Probe Cleaning Kit (SER-01). Once cleaned, sensor cleanliness should be confirmed via the uPyxis 2.0 APP diagnostics function, then the user may proceed to sensor zero and slope calibration. See Cleaning Section 8.0 for details.

## 2. Specifications

| Item  | ST-500SS-T   |
|---|--|
| P/N   | 51152  |
| PTSA Output Scale<br><i>4-20mA Default</i>  | 0-500ppb   |
| 4-20mA SPAN<br><i>Adjustable via uPyxis</i> | 20mA SPAN value may be adjusted to less than max range via uPyxis APP        |
| PTSA Resolution                             | +/- 1.0 ppb  |
| Calibration                                 | Two Point Calibration Against DI Water + PTSA Standard Solution              |
| Power Supply                                | 22 – 26V DC, Power Consumption – 2W  |
| Outputs                                     | Isolated 4 – 20 mA Analog Outputs & Isolated RS-485 Digital Output -7Pin     |
| Installation                                | ST-009 Stainless Steel Tee – ¼-inch FNPT threaded ports<br>(sold separately) |
| Weight                                      | 1.1lbs (500g)  |
| Operational Pressure                        | 290 psi (20 Bar) when used with ST-009                                       |
| Operating Temperature                       | 4 °C – 49 °C (40 – 120 °F)   |
| Storage Temperature                         | -20 °C – 60 °C (-4 – 140 °F)   |
| Material                                    | 316SS Sensor & 316SS ST-009  |
| Rating                                      | IP67, Fully Dustproof & Waterproof   |
| Dimension (L x W x H) †                     | Length 6.9 inch (177 mm), body diameter 1.34 Inch (34mm)                     |
| Cable Length                                | 1.5m 7Pin Bulkhead w/adapter + 1.5m 7Pin Flying Lead w/adapter               |
| Regulation                                  | CE, RoHS, UKCA   |

\* Specifications are subject to change without notice.

† See Figure 3 for ST-500SS-T Series dimensions.

### 3 Unpacking Instrument

Remove the instrument and accessories from the shipping container and inspect each item for any damage that may have occurred during shipping. Verify that all accessory items are included. If any item is missing or damaged, please contact Pyxis Lab Customer Service at [service@pyxis-lab.com](mailto:service@pyxis-lab.com).

#### 3.1 Standard Accessories

- One **ST-500SS-T** (P/N: 51152) with 1.5m bulkhead cable with 7-pin Female Adapter
  - **NOTE** - *ST-009 Stainless Steel Tee Assembly is Sold Separately*
- One **MA-1100** - 7-Pin Flying Leads Cable with Male Adapter (5ft) (P/N: 50747)
- User Manual available online at <https://pyxis-lab.com/support/>

#### 3.2 Optional Accessories

The following optional accessories can be ordered from Pyxis Customer Service ([order@pyxis-lab.com](mailto:order@pyxis-lab.com)) or Pyxis E-Store at <https://pyxis-lab.com/shop/>.

| Accessory Name  | P/N      |
|---|----------|
| ST-009 Stainless Steel Inline Tee Assembly<br><i>(<math>\frac{3}{8}</math>-inch FNPT Stainless Steel)</i> | 22624    |
| PTSA-100<br><i>(PTSA Calibration Standard 10ppb/ 500ml)</i>   | 21001    |
| PTSA-200<br><i>(PTSA Calibration Standard 200ppb/ 500ml)</i>  | 21000    |
| Pyxis Probe Cleaning Kit<br><i>(Includes Sensor Cleaner 500mL + Accessories)</i>                          | SER-01   |
| MA-WB Bluetooth/USB Adapter<br><i>(Pyxis Bluetooth/USB Adapter for 7Pin Pyxis Sensors)</i>                | MA-WB    |
| PowerPACK-1<br><i>(Single Chanel Auxiliary Power Supply w/Bluetooth for Pyxis Sensors)</i>                | MA-BLE-1 |
| PowerPACK-4<br><i>(Four Chanel Auxiliary Power Supply w/Bluetooth for Pyxis Sensors)</i>                  | MA-BLE-4 |
| SP-380 PTSA + PTSA Handheld<br><i>(PTSA 0-300ppb / 0-600ppb Fluor)</i>                                    | 50208    |
| MA-C10<br><i>(10' Extension Cable for 7Pin Pyxis Sensors)</i>   | 50738    |
| MA-C50<br><i>(50' Extension Cable for 7Pin Pyxis Sensors)</i>   | 50705    |

## 4 Installation

### 4.1 ST-500SS-T installed in the ST-009 Stainless Steel Tee Assembly

The ST-500SS-T sensor must be used with the ST-009 stainless steel inline tee assembly for use in high pressure applications exceeding 100psi. The maximum pressure of the sensor and tee assembly is 290psi. The ST-009 provides 3/4-inch FNPT threaded inlet and outlet for easy plumbing. The sensor should be installed horizontally with sample flow entering the bottom of the tee and exiting the top. **\*NOTE\*** The ST-009 is sold separately.

To properly install the ST-500SS-T sensor into the ST-009 Tee Assembly, follow the steps below:

1. The recommended installation of the sensor and tee is horizontal with sample flow entering the bottom of the tee and exiting the top. This ensures proper sensor optical channel flooding.
2. Insert the provided O-ring into the O-ring groove on the tee.
3. Insert the ST-500SS-T series sensor into the ST-009 tee.
4. Tighten the tee nut onto the tee to form a water-tight, compression seal.

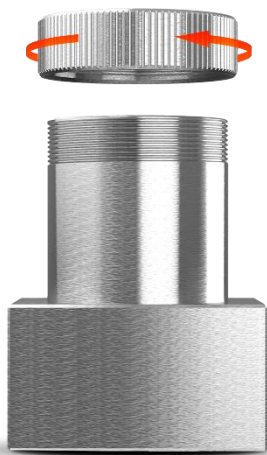

Figure 1. ST-009 Image

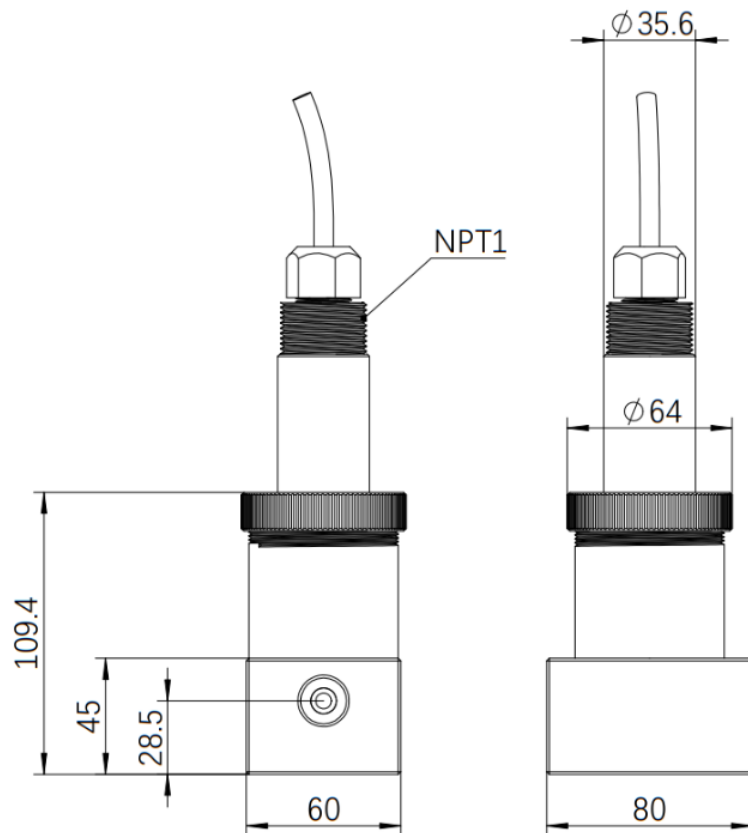
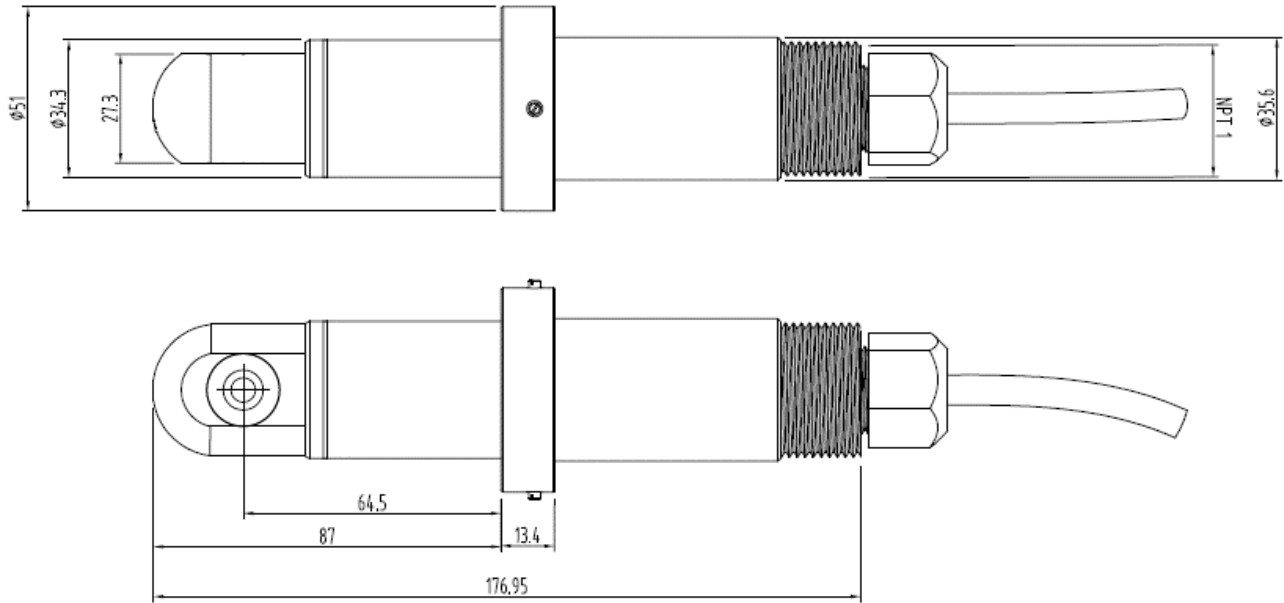

Figure 2. ST-009 Tee Assembly (mm)

**4.2 ST-500SS-T Dimension**

The ST-500SS-T dimensions can be found below.



**Figure 3.** Dimension of the ST-500SS-T (mm)

### 4.3 Wiring

Follow the wiring tables below to connect the ST-500SS-T probe to a receiving controller.

**\*NOTE\***: *The 24V power ground (black) and the 4-20 mA- return (green) are internally connected. If an insufficient wattage is available from the connected controller (i.e. 2W), Pyxis recommends the **PowerPACK Series** Auxiliary Power & Bluetooth Communication Adapters highlighted in the Optional Accessories section of this manual. If a separate DC power supply other than that from the controller is used, make sure that the output from the power supply is rated for 22-26 VDC @ 65mA. Detailed wiring diagrams for common controllers are available from [www.pyxis-lab.com](http://www.pyxis-lab.com)*

Table 2

| Wire Color | Designation          |
|------------|----------------------|
| Red        | 24 V +               |
| Black      | 24 V- Power Ground   |
| White      | 4-20 mA + for PTSA   |
| Green*     | 4-20mA -             |
| Blue       | RS-485 A             |
| Yellow     | RS-485 B             |
| Clear      | Shield, earth ground |

\* 4-20mA- and Power Ground are internally connected

#### 4.4 Connecting via Bluetooth to a Mobile Device

An MA-WB Bluetooth/USB adapter (P/N: MA-WB) can be used to connect a ST-500SS-T sensor to a smart device with the **uPyxis®2.0** Mobile App. The power should be sourced from a 24 VDC power terminal of a connected controller. If a controller is not available, please purchase a Pyxis PowerPack-1 (P/N: MA-BLE-1) or PowerPack-4 (P/N: MA-BLE-4) auxiliary power supply with Bluetooth, or an alternative 24 V power supply that can directly connect to the ST-500SS-T sensor with proper cable connectors from Pyxis.

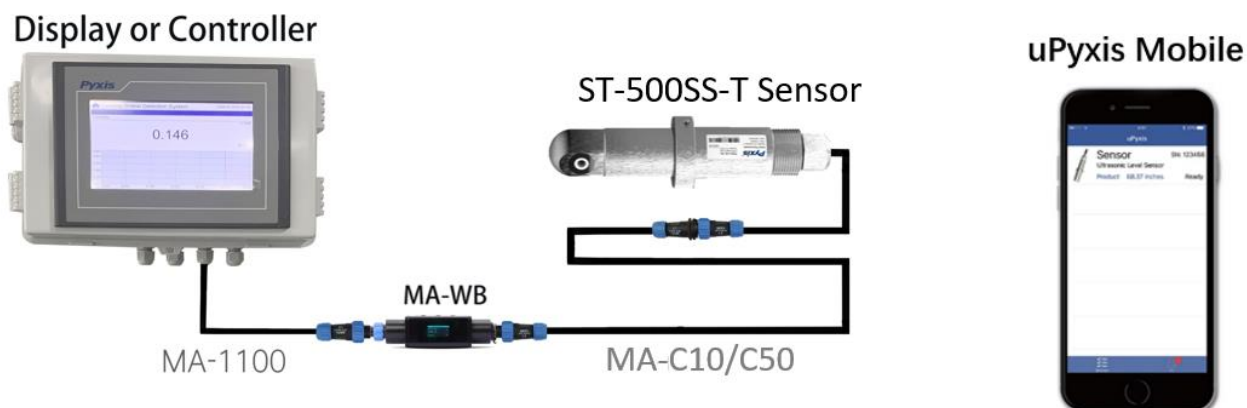

**Figure 4.** MA-WB Bluetooth connection to 7-Pin Pyxis sensor and uPyxis 2.0 Mobile App

## 5 Calibration and Diagnosis with the uPyxis®2.0 Mobile App

The ST-500SS-T sensor can be calibrated in a two-point (zero + slope) procedure using a deionized (DI) water sample and a Pyxis 100ppb PTSA calibration standard solution (P/N 21001). Higher concentration calibration standard may also be used if desired based on the application need. The calibration solution can also be the sample water itself. The concentration of PTSA in the sample water can be determined by using a Pyxis SP-380 (P/N: 50208), or similar offline fluorometer or calculated from the concentration of any measurable species in the sample water such as polymer, phosphate, or molybdate.

**\*IMPORTANT NOTE\*** *Direct sunlight or indoor light on the ST-500SS-T sensor should be avoided although it is not necessary to completely shield the ST-500SS-T sensor from the ambient light during both the zero point and slope calibrations.*

### 5.1 Download and Connect to the uPyxis® 2.0 Mobile App



Install the MA-WB Bluetooth adapter as outlined in Figure 4.

Download and install the **uPyxis2.0** app from **Apple Store** or **Google Play**. Turn ON the Bluetooth in the smart device being used. Please do not pair your devices Bluetooth to uPyxis, the app will do the pairing. Open the uPyxis app on the device. Click the **Scan Bluetooth** button to scan the available Pyxis Bluetooth devices. The discovered devices will be listed as shown in *Figure 5*. This may take up to one minute.

Tap the discovered ST-500SS-T sensor to connect to the sensor. The uPyxis app will identify the sensor type if multiple Pyxis sensors are discovered in the scan.

As shown in *Figure 6*, uPyxis will default to the **Trend Chart** page after connected to the sensor via the MA-WB Bluetooth adapter. The measurement value will be displayed as a line graph to show the real-time trend.

Tap **Configuration** in the top of the app page to launch the configuration page. Five functional tabs of each are available on this page: Information, Configuration, Calibration, 4-20mA Span and Diagnosis.

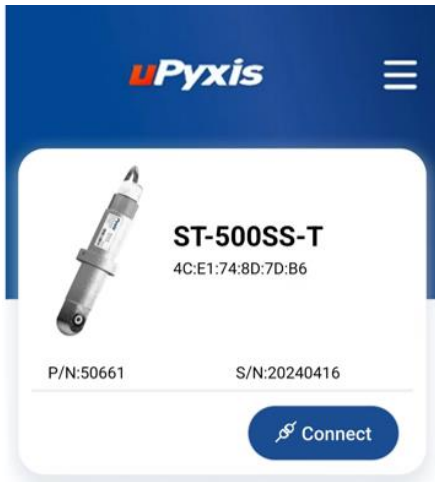

Figure 5.

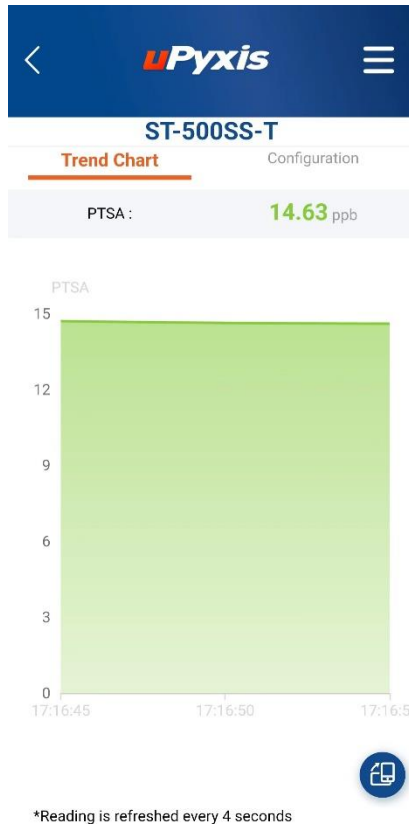

Figure 6.

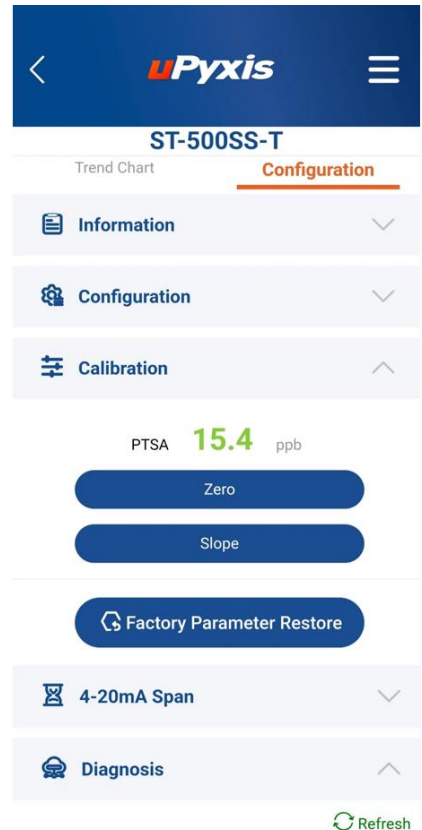

Figure 7.

## 5.2 PTSA Calibration via uPyxis 2.0 Mobile App

### Single Point (In-Situ) PTSA Calibration

If you have confirmed the ST-500SS-T sensor is clean by using the Cleanliness Check Function of the Diagnostic tab within uPyxis 2.0 (see section 5.4), users may conduct an in-situ slope calibration of PTSA while the sensor is in operation. Users can tap **Slope CALIBRATION** and enter the handheld measured PTSA value, then hit confirm.

**\*NOTE\*** *If the sensor is dirty, it must be removed for proper optical channel cleaning with the Pyxis Probe Cleaning Solution (P/N SER-01) prior to conducting sensor calibration. Confirmation of sensor cleanliness with the uPyxis 2.0 APP Cleanliness Check Function is required before proceeding to sensor calibration.*

See instructional video here <https://www.youtube.com/watch?v=hFmk2znyvjs&pp=ygUlChI4aXMqbWE%3D>

### Two-Point (Beaker) PTSA Calibration

Two-point PTSA calibration for the ST-500SS-T requires the following depending on the sensor in use. (see the Optional Accessories Section 3.2). **\*NOTE\***: For best results, the ST-500SS-T sensor should be calibrated in a completely light-proof environment by covering the beaker with a towel.

#### **ST-500SS-T (0-500ppb)**

- Zero = DI Water
- Slope = 100ppb or 200ppb PTSA Calibration Standard
  - o PTSA-100 (P/N 21001)
  - o PTSA-200 (P/N 21000)

After confirming sensor cleanliness as outlined above, place the sensor into a beaker containing deionized (DI) water, then tap **ZERO CALIBRATION** in the uPyxis app. Please allow sufficient time (a few minutes) for the sensor to stabilize before performing the calibration.

After completing the zero calibration, place the sensor into PTSA-100 or PTSA-200 calibration standard solution (based on the application range) and tap **SLOPE CALIBRATION** in the uPyxis app. Enter the PTSA concentration of the calibration standard used in the dialog window as in *Figure 8*.

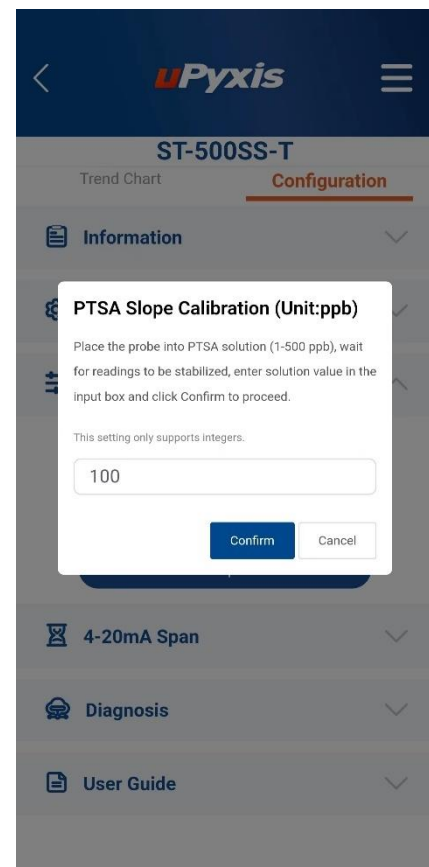

Figure 8.

### 5.3 Adjusting the 4-20mA Span via uPyxis 2.0 Mobile App

From the Pyxis factory, the 4–20mA output of the ST-500SS-T sensor is scaled as follows:

| Sensor Name | 4mA Value | 20mA Value |
|-------------|-----------|------------|
| ST-500SS-T  | 0 ppb     | 500 ppb    |

Users may alter the output scale using **4-20mA Span** to change the PTSA value corresponding to the 20mA output (Figure 9).

**\*NOTE\*** The 20mA value span adjustment may only be equal to or lower than the upper range detection limit of the sensor.

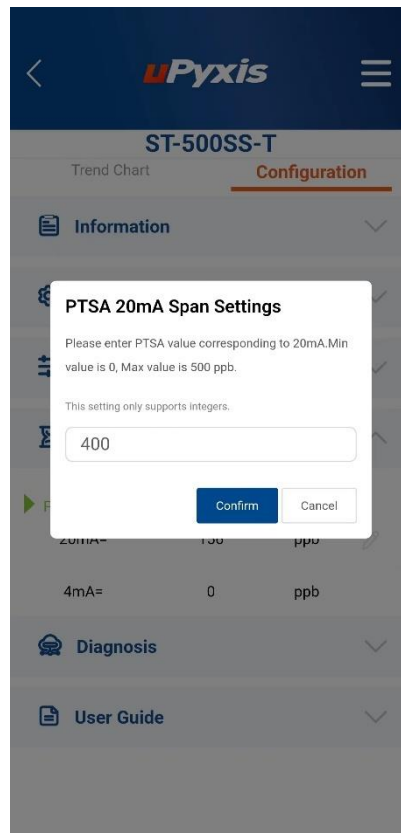

Figure 9 – Adjust 20mA Setting for PTSA

## 5.4 Diagnosis Screen

Tap **Diagnosis** in the bottom of the **Configuration** page 10.

When in the Diagnosis screen you can view the Diagnosis Condition of the device. This feature may be used for technical support when communicating with [service@pyxis-lab.com](mailto:service@pyxis-lab.com).

To perform a sensor Cleanliness Check, first select the Diagnosis Condition which defines the fluid type that the ST-500SS-T sensor is currently measuring, then click **Cleanliness Check**. If the sensor is clean, a **Clean** message will be shown. If the sensor is fouled, a **Becoming Dirty** or **Dirty** message will be shown. In this case, follow the procedure in the Methods to Cleaning the ST-500SS-T section of this manual.

The screenshot displays the Pyxis ST-500SS-T interface. At the top, there is a navigation bar with a back arrow, the Pyxis logo, and a menu icon. Below this, the device name 'ST-500SS-T' is shown, with 'Trend Chart' and 'Configuration' tabs. The 'Diagnosis' section is active, showing a table of 12 data points. A 'Refresh' button is located to the right of the table. Below the table, the 'Diagnosis Condition' section is visible, followed by a large blue 'CLEANLINESS CHECK' button. Below this button, a green 'Clean' button is displayed, indicating the probe is in good condition.

|      |           |      |
|------|-----------|------|
| [1]  | 31 [mA]   | 5.47 |
| [2]  | 40 [3]    | 40   |
| [4]  | 32 [5]    | 16   |
| [6]  | 2917 [7]  | 8    |
| [8]  | 394 [9]   | 468  |
| [10] | 1037 [11] | 127  |
| [12] | 209 [13]  | 3986 |

Diagnosis Condition

CLEANLINESS CHECK

Clean

Probe is in good condition.

Figure 10.

## 6 Calibration and Diagnosis with the uPyxis® Desktop App

### 6.1 Download and Connect to the uPyxis Desktop® App

1. Download and install uPyxis Desktop APP from <https://upyxis.pyxis-lab.com.cn/release/pc/uPyxis.Setup-latest.zip>
2. Connect a USB Type-C cable to the port at the bottom of the MA-WB and to the USB port of the laptop or computer. This will provide power to the MA-WB from the laptop/computer. Connect the MA-WB to the ST-500SS-T sensor. The MA-WB Bluetooth adapter will boost the 5V of the regular USB to 24V to power the sensor for use with uPyxis Desktop.



MA-WB Bluetooth Adapter – Bottom USB-C

#### Display or Controller

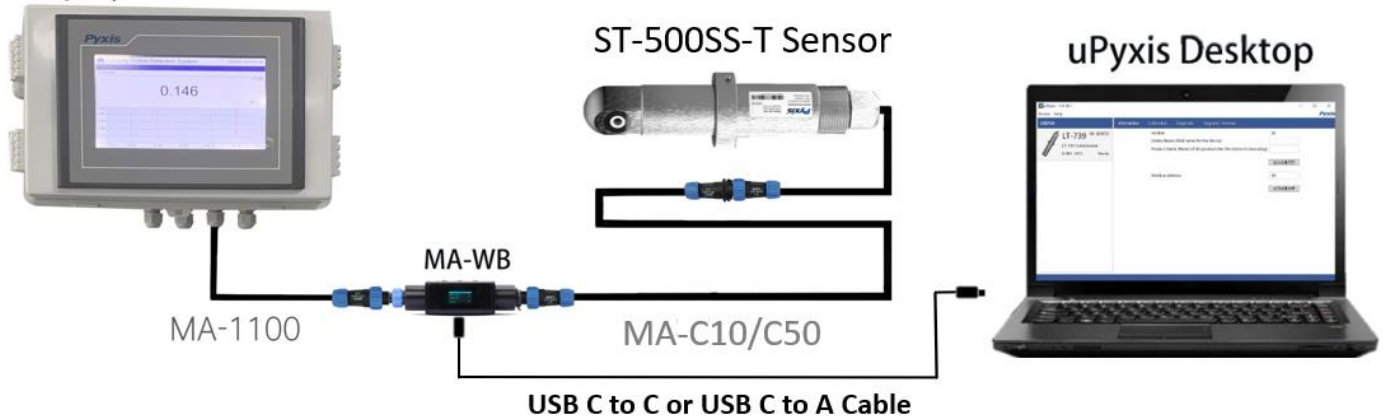

Figure 11 – 7-Pin Pyxis Sensor / MA-WB / USB-C Cable connected to uPyxis Desktop

3. Set the MA-WB to operate in USB Mode by following the steps below.
  - a. Once the MA-WB screen is powered Press ◀ or ▶ until you arrive at (USB to RS485) screen.
  - b. Press the **OK** Button.
  - c. Follow Prompts below to Enable USB feature. Once enabled, you may connect to uPyxis.



4. Open the desktop uPyxis APP.
5. Click Device to launch the connection option menu.
6. Select Connect via USB-RS485 (Figure 12).
7. Select the Comm Port to make a connection. Normally only one Comm port is identified by uPyxis (Figure 13). If more than one Comm port listed in the selection dropdown, you may try to select each one to see if a connection can be made. Alternatively, you may use the Windows Device Manager to identify the Comm Port that the Pyxis USB adapter is using.

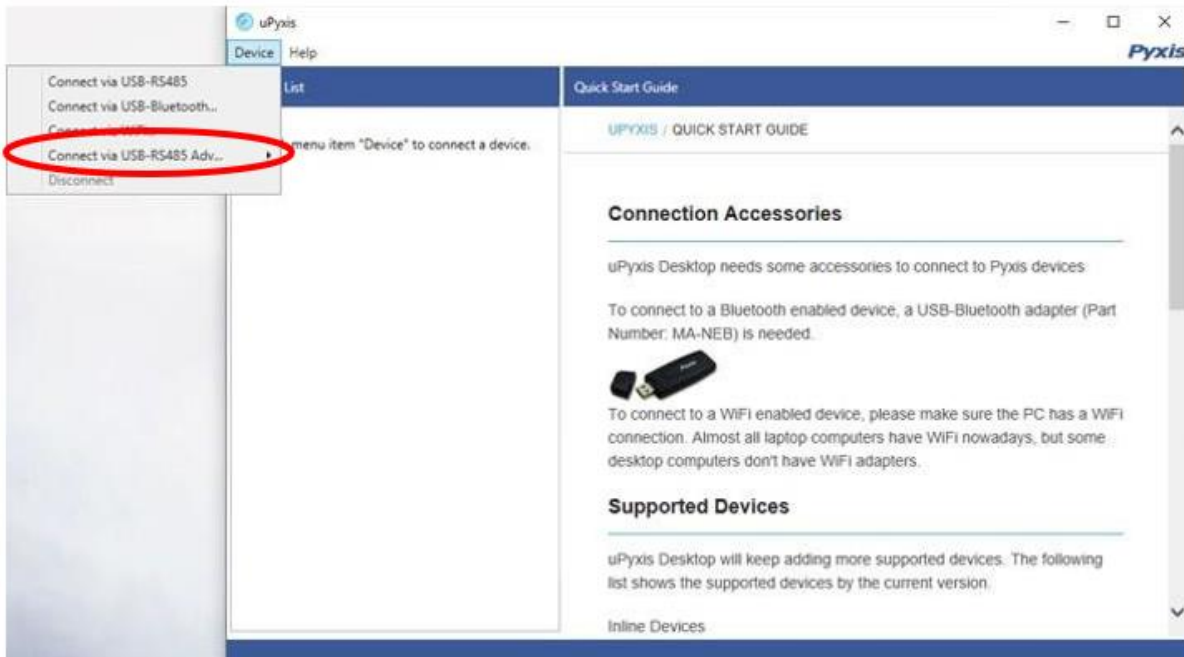

Figure 12. Connection Options

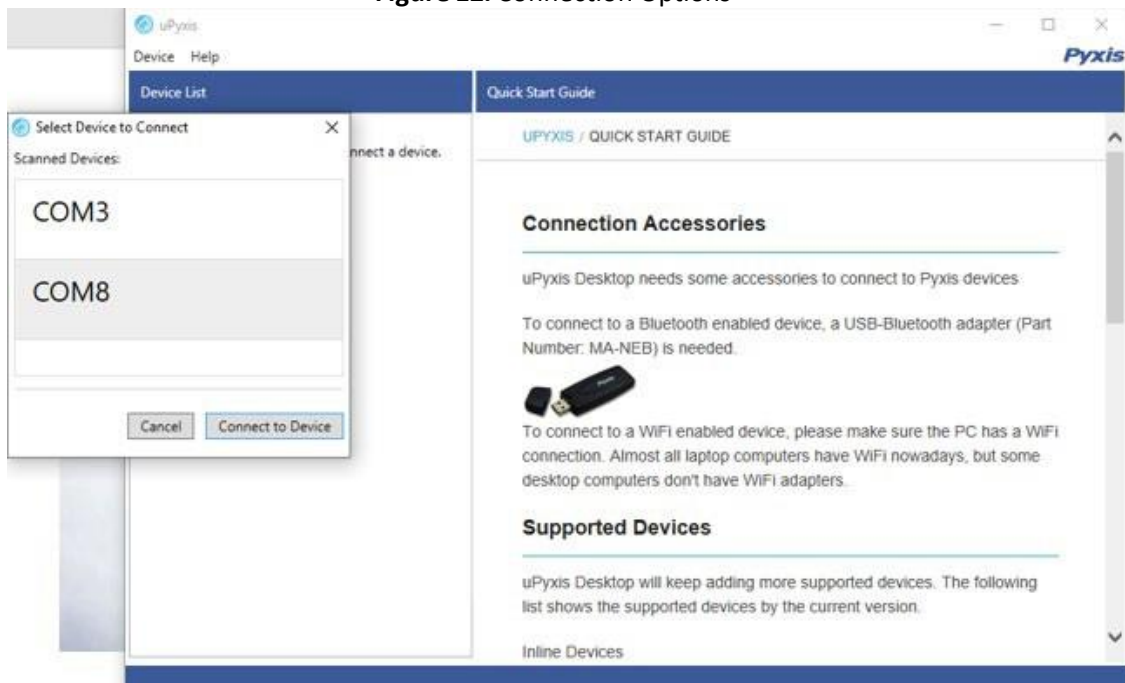

Figure 13. Select a Comm port

### 6.2 Information Screen

Once connected to the device, a picture of the device will appear on the top left corner of the window and the uPyxis® Desktop App will default to the **Information** screen. On the **Information** screen you can set the information description for **Device Name** and **Product Name**, then click **Set** to save.

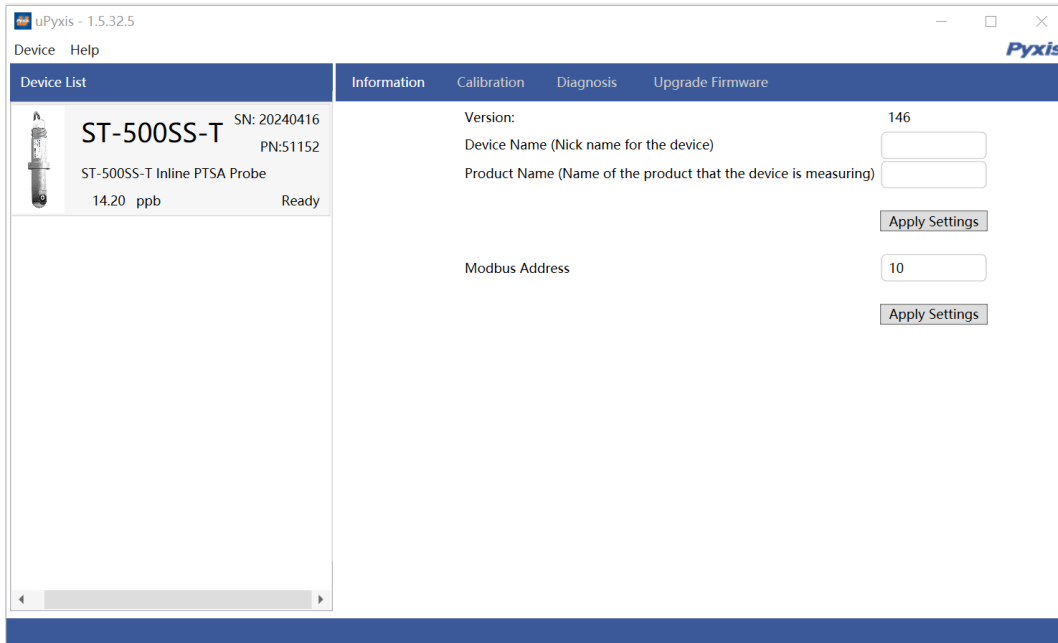

Figure 14.

### 6.3 Calibration Screen

To calibrate the device, click on **Calibration**. On the **Calibration** screen there are three calibration tabs, **Zero Calibration**, **Slope Calibration**, and **4-20mA Span**. The screen also displays the reading of the device. The reading refresh rate is every 4 seconds. Follow the screen instructions for each calibration step.

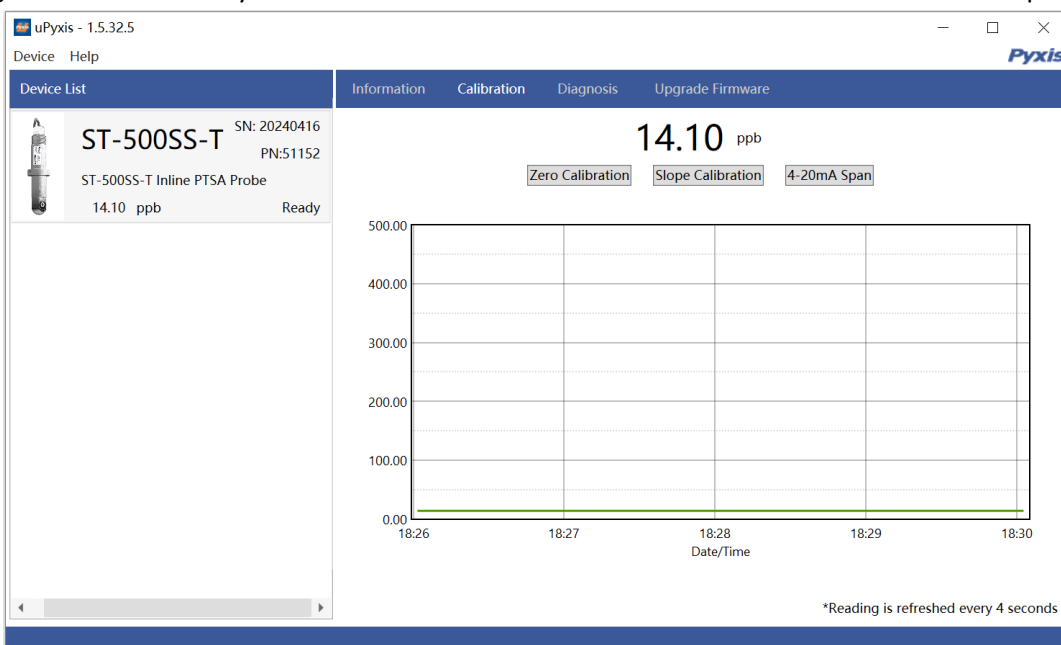

Figure 15.

## 6.4 PTSA Calibration via uPyxis Desktop App

### Single Point (In-Situ) PTSA Calibration

If you have confirmed the ST-500SS-T sensor is clean by using the Cleanliness Check Function of the Diagnostic tab within uPyxis Desktop (see section 6.5), users may conduct an in-situ slope calibration of PTSA while the sensor is in operation. Users can tap **Slope CALIBRATION** and enter the handheld measured PTSA value, then hit confirm. **\*NOTE\*** *If the sensor is dirty, it must be removed for proper optical channel cleaning with the Pyxis Probe Cleaning Solution (P/N SER-01) prior to conducting sensor calibration. Confirmation of sensor cleanliness with the uPyxis Desktop Cleanliness Check Function is required before proceeding to sensor calibration.*

### Two-Point (Beaker) PTSA Calibration

Two-point PTSA calibration for the ST-500SS-T requires the following depending on the sensor in use. (see the Optional Accessories Section 3.2). **\*NOTE\***: *For best results, the ST-500SS-T Series sensor should be calibrated in a completely light-proof environment by covering the beaker with a towel.*

### ST-500SS-T (0-500ppb)

- Zero = DI Water
- Slope = 100ppb or 200ppb PTSA Calibration Standard
  - o PTSA-100 (P/N 21001)
  - o PTSA-200 (P/N 21000)

After confirming sensor cleanliness as outlined above, place the sensor into a beaker containing deionized (DI) water, then tap **ZERO CALIBRATION** in the uPyxis app. Please allow sufficient time (a few minutes) for the sensor to stabilize before performing the calibration.

After completing the zero calibration, place the sensor into PTSA-100 or PTSA-200 calibration standard solution (based on the application range) and tap **SLOPE CALIBRATION** in the uPyxis app. Enter the PTSA concentration of the calibration standard used in the dialog window as in *Figure 16*.

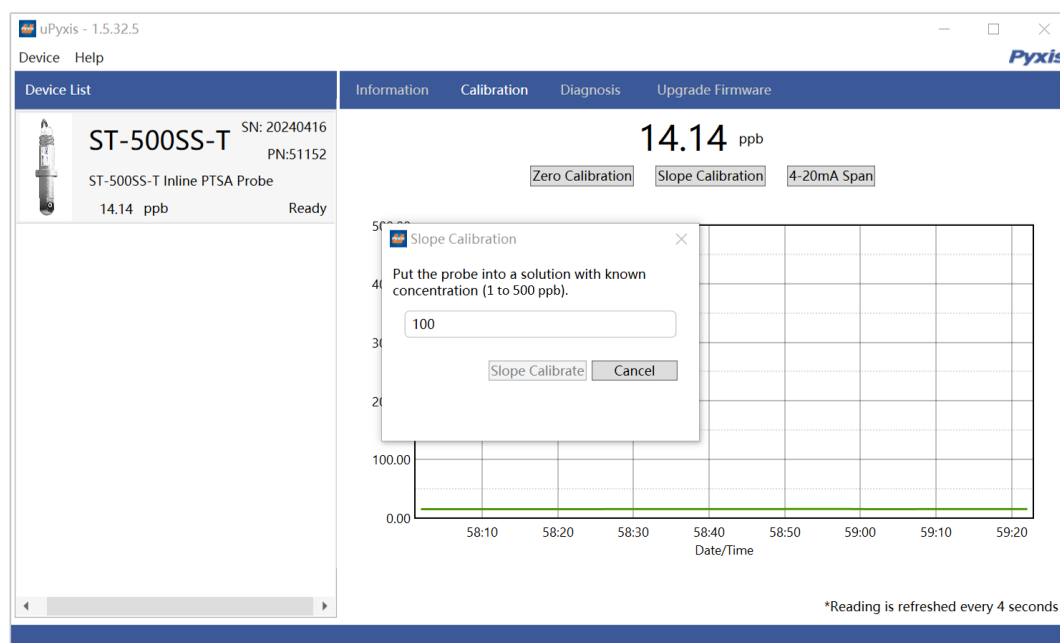

Figure 16. – Slope Calibration

## 6.5 Diagnosis Screen

After the device has been calibrated and installation has been completed, to check diagnosis, click on **Diagnosis**. When in the **Diagnosis** screen you can view the Diagnosis Condition of the device. This feature may be used for technical support when communicating with [service@pyxis-lab.com](mailto:service@pyxis-lab.com).

To perform a Cleanliness Check, first select the **Diagnosis Condition** which defines the fluid type that the ST-500SS-T sensor is currently measuring, then click **Cleanliness Check**. If the sensor is clean, a green **Clean** message will be shown. If the sensor is severely fouled, a red **Dirty** message will be shown. In this case, follow the procedure in the **Methods to Cleaning the ST-500SS-T Sensor** section of this manual.

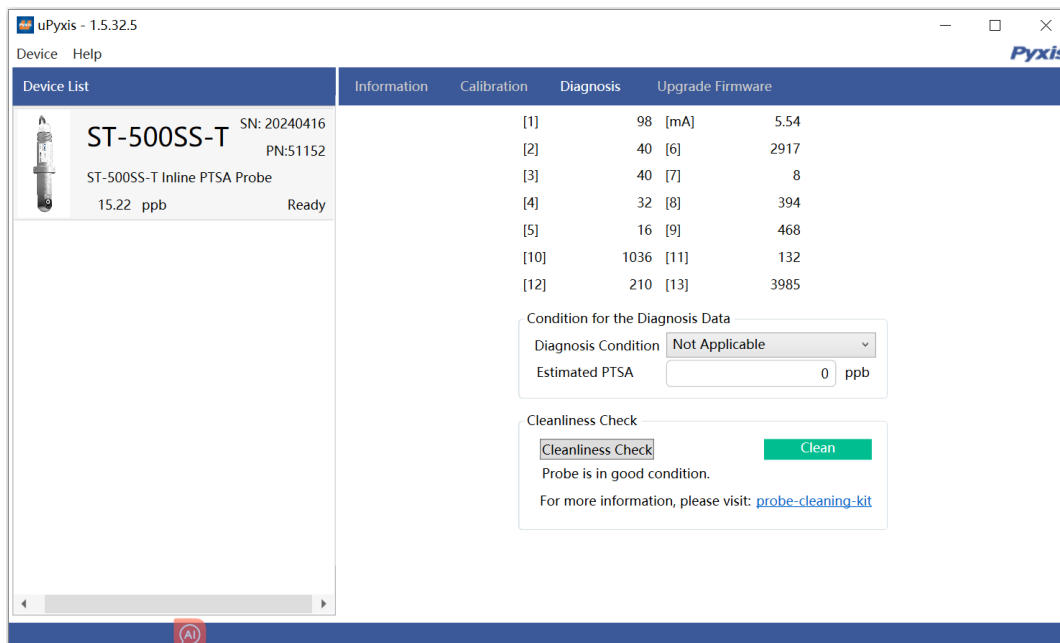

Figure 17.

## 7 Outputs

### 7.1 4–20mA Output Setup

The 4–20mA output of the ST-500SS-T sensor should be scaled as outline below.

| Sensor Name | 4mA Value | 20mA Value |
|-------------|-----------|------------|
| ST-500SS-T  | 0 ppb     | 500 ppb    |

### 7.2 Adjusting 4–20mA Span via uPyxis Desktop

Users may adjust the output scale using 4–20mA Span to change the PTSA value corresponding to the 20mA output via uPyxis®. For the uPyxis® Desktop App, click **4-20mA Span** found on the **Calibration Screen**, shown in Figure 18. **\*NOTE\* - The 20mA value may only be adjusted to a value less than or equal to the upper range of the sensor.**

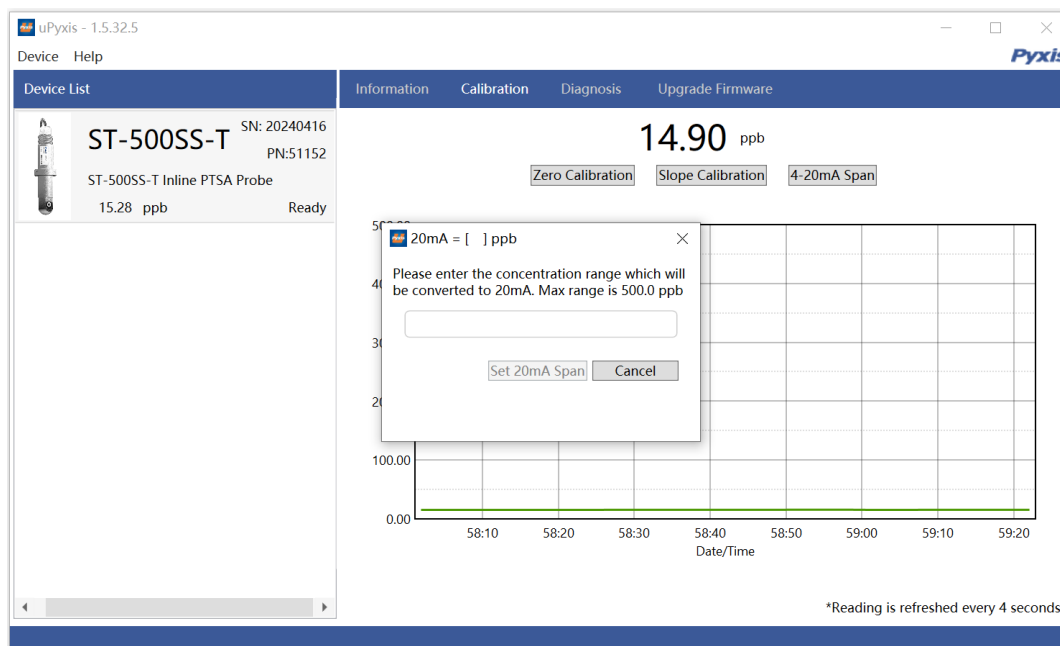

Figure 18.

### 7.3 Communication using Modbus RTU

The ST-500SS-T Series sensor is configured as a Modbus slave device. In addition to the ppb PTSA value, many operational parameters, including warning and error messages, are available via a Modbus RTU connection. Contact Pyxis Lab Customer Service ([service@pyxis-lab.com](mailto:service@pyxis-lab.com)) for more information.

## 8 Sensor Maintenance and Precaution

The ST-500SS-T sensor is designed to provide reliable and continuous PTSA readings even when installed in moderately contaminated industrial waters. Although the optics are compensated for the effects of moderate fouling, heavy fouling will prevent the light from reaching the sensor, resulting in low readings and the potential for product overfeed if the ST-500SS-T sensor is used as part of an automated control system. When used to control product dosing, it is suggested that the automation system be configured to provide backup to limit potential product overfeed, for example by limiting pump size or duration, or by alarming if the pumping rate exceeds a desired maximum limit.

The ST-500SS-T sensor is designed to be easily removed from the ST-009 inline tee assembly, inspected, and cleaned if required. It is suggested that the ST-500SS-T sensor be checked for fouling and cleaned/calibrated monthly. Heavily contaminated waters may require more frequent cleanings. Cleaner water sources with less contamination may not require cleaning for several months.

The need to clean the ST-500SS-T sensor can be determined by the **Cleanliness Check** using either the **uPyxis®2.0** Mobile App (see the **Mobile Diagnosis Screen** section) or the **uPyxis®** Desktop App (see the **Desktop Diagnosis Screen** section).

## 8.1 Methods to Cleaning the ST-500SS-T Sensor

Any equipment in contact with industrial cooling or process systems is subject to potential foulants and contaminants. Our inline sensor cleaning solution below has been shown to remove the most common inorganic foulants and contaminants. A small, soft bristle brush, Q-Tips cotton swab, or soft cloth may be used to safely clean the sensor housing and the quartz optical sensor channel. These components and more come with a Pyxis Lab **Inline Probe Cleaning Solution Kit** (P/N: SER-01) which can be purchased at our online E- Store <https://pyxis-lab.com/product/st-series-probe-cleaning-kit/>



**Figure 19.** Inline Probe Cleaning Solution Kit (P/N SER-01)

To clean the ST-500SS-T sensor, soak the lower half of the sensor in 100 mL inline sensor cleaning solution for 10 minutes. Rinse the ST-500SS-T sensor with distilled water and then check for the flashing blue light inside the sensor's quartz tube (optical channel). If the surface is not entirely clean, continue to soak the ST-500SS-T sensor for an additional time. Use the small, soft bristle brush and Q-Tips cotton swabs as necessary to remove any remaining contaminants in the ST-500SS-T sensor quartz tube.

## 8.2 Storage

Avoid long term storage at temperatures over 140 °F. In an outdoor installation, properly shield the ST-500SS-T sensor from direct sunlight and precipitation.

## 9 Troubleshooting

If the ST-500SS-T sensor output signal is not stable and fluctuates significantly, make an additional ground connection — connect the clear (shield, earth ground) wire to a conductor that contacts the sample water electrically such as a metal pipe adjacent to the ST-009 inline tee.

Carry out routine calibration verification against a qualified PTSA standard. After properly cleaning the ST-500SS-T sensor, carry out the zero-point calibration with distilled water and slope calibration using the qualified PTSA standard.

## 10 Contact Us

**Pyxis Lab, Inc**  
2124 Spell Circle  
Tomball, TX. 77375 USA  
[www.pyxis-lab.com](http://www.pyxis-lab.com)  
Phone: +1 (866) 203-8397  
Email: [service@pyxis-lab.com](mailto:service@pyxis-lab.com)