

Pyxis[®] | User Manual

prism RT-50

*Inline Refractometer with
User Defined Solution Capability*



Pyxis Lab, Inc.
1729 Majestic Drive (Suite 05)
Lafayette, Colorado 80026
+1 (866) 203-8397

Table of Contents

| | | |
|----------|--|-----------|
| 1 | Introduction | 2 |
| 1.1 | Main Features | 2 |
| 2 | Specifications | 3 |
| 3 | Unpacking Instrument | 4 |
| 3.1 | Standard Accessories | 4 |
| 3.2 | Optional Accessories | 5 |
| 4 | Installation | 5 |
| 4.1 | Main Assembly | 5 |
| 4.2 | Piping | 6 |
| 4.3 | Wiring | 7 |
| 5 | Instrument Overview | 9 |
| 5.1 | Key Functions | 9 |
| 5.2 | Measurement Modes | 9 |
| 5.3 | Sensitivity Setup | 10 |
| 5.4 | Cleaning Cycle Setup | 10 |
| 5.5 | Reset Parameters | 10 |
| 6 | Calibration | 11 |
| 6.1 | Air Calibration of Refractive Index | 11 |
| 6.2 | Brix and Other Liquid Concentration Offset Calibration | 12 |
| 7 | Setup and Configuration with uPyxis® Mobile App | 12 |
| 7.1 | Download uPyxis® Mobile App | 12 |
| 7.2 | Connecting to uPyxis® Mobile App via Bluetooth | 13 |
| 7.3 | Calibration Screen and Reading | 14 |
| 7.4 | Add/Modify Custom Fluid | 14 |
| 7.5 | Diagnosis Screen | 17 |
| 7.6 | Device Info Screen | 18 |
| 8 | Setup and Calibration with uPyxis® Desktop App | 18 |
| 8.1 | Install uPyxis® Desktop App | 18 |
| 8.2 | Connecting to uPyxis® Desktop App via USB-C Cable | 19 |
| 8.3 | Information Screen | 21 |
| 8.4 | Calibration Screen | 22 |

| | | |
|-----------|--|-----------|
| 8.5 | Add/Modify Custom Fluid..... | 23 |
| 8.6 | Diagnosis Screen | 24 |
| 9 | Outputs..... | 26 |
| 9.1 | 4–20mA Output Setup | 26 |
| 9.2 | Communication using Modbus RTU | 26 |
| 10 | Sensor Maintenance and Precaution | 27 |
| 10.1 | Methods to Cleaning the Prism RT-50 | 27 |
| 11 | Contact Us..... | 27 |

Warranty Information

Confidentiality

The information contained in this manual may be confidential and proprietary and is the property of Pyxis Lab, Inc. Information disclosed herein shall not be used to manufacture, construct, or otherwise reproduce the goods described. Information disclosed herein shall not be disclosed to others or made public in any manner without the express written consent of Pyxis Lab, Inc.

Standard Limited Warranty

Pyxis Lab warrants its products for defects in materials and workmanship. Pyxis Lab will, at its option, repair or replace instrument components that prove to be defective with new or remanufactured components (i.e., equivalent to new). The warranty set forth is exclusive and no other warranty, whether written or oral, is expressed or implied.

Warranty Term

The Pyxis warranty term is thirteen (13) months ex-works. In no event shall the standard limited warranty coverage extend beyond thirteen (13) months from original shipment date.

Warranty Service

Damaged or dysfunctional instruments may be returned to Pyxis for repair or replacement. In some instances, replacement instruments may be available for short duration loan or lease.

Pyxis warrants that any labor services provided shall conform to the reasonable standards of technical competency and performance effective at the time of delivery. All service interventions are to be reviewed and authorized as correct and complete at the completion of the service by a customer representative, or designate. Pyxis warrants these services for 30 days after the authorization and will correct any qualifying deficiency in labor provided that the labor service deficiency is exactly related to the originating event. No other remedy, other than the provision of labor services, may be applicable.

Repair components (parts and materials), but not consumables, provided during a repair, or purchased individually, are warranted for 90 days ex-works for materials and workmanship. In no event will the incorporation of a warranted repair component into an instrument extend the whole instrument's warranty beyond its original term.

Warranty Shipping

A Repair Material Authorization (RMA) Number must be obtained from Pyxis Technical Support before any product can be returned to the factory. Pyxis will pay freight charges to ship replacement or repaired products to the customer. The customer shall pay freight charges for returning products to Pyxis. Any product returned to the factory without an RA number will be returned to the customer. To receive an RMA you can generate a request on our website at <https://www.pyxis-lab.com/request-return-or-repair/>

Pyxis Technical Support

Contact Pyxis Technical Support at +1 (866) 203-8397 or service@pyxis-lab.com

1 Introduction

The Pyxis RT-50 Prism is an inline digital refractometer that measures the refractive index of a liquid sample and provides a direct reading of highly accurate concentration values for a wide variety of process applications including cutting fluid concentration detection. It is a stand-alone device capable of self-sustained operation, live data display and data logging. The RT-50 Prism also offers fully integrated 4-20mA and RS-485 Modbus output signals for connectivity to any microprocessor-based controller, display, PLC or DCS network. The RT-50 Prism has built-in temperature dependent equations to convert the optical lens measured sample temperature and refractive index to the Brix concentration. User defined concentration curves and output may also be programmed to the RT-50 through the uPyxis APP interface through user entry of know formula coefficient values. This enables the RT-50 to provide a user-customized display and output of the concentration of the material being measured, as desired.



NOTE *The Prism RT-50 is a very robust sensor and capable of operating in contaminated fluid samples. It is important, however, to note that users should take all precautions to prevent and filter suspended solids from the sample stream prior to the sensor to avoid tenacious deposit build-up on the sensor eye. In highly fouled applications, Pyxis recommends users conduct sensor eye cleaning on a regular basis. Pyxis Lab offers the [Ultra-Sonic RT-50 Cleaning Module Kit \(P/N 56208\)](#) for installation into the Tri-Clamp Flow Cell Assembly as an optional accessory allowing for automated online cleaning of the RT-50 refractive index sensor. Contact www.order@pyxis-lab.com for technical and pricing details of this online cleaning accessory.*

1.1 Main Features

- Dual 4-20 mA output of sample temperature and the unit of display selected via the screen interface
- User customizable product name, concentration and 4-20mA output ranges with uPyxis APP
- RS-485 Modbus RTU output of temperature, refractive index and other diagnosis parameters
- Built-in temperature dependent equations % BRIX
- User Defined Product Concentration Curve Entry via uPyxis APP
- Local Display and Push-Button Interface
- Optional 110/220VAC – 24 VDC Wall Outlet Powered for Independent Operation w/out controller
- Built-In Historical Data Log up to 56 Days of Storage at 1 Reading Per Minute via uPyxis APP
- Bluetooth Enabled when used with MA-CR Bluetooth Adapter
- Sturdy 316L stainless-steel construction and suitable for harsh application environments
- Convenient Stainless-Steel Tri-Clamp Flow Cell Assembly w ¾-inch NPT Flange
- Easy Installation and Removal for Cleaning and Maintenance – No Tools Needed
- Automatic Cleaning with RT-Series Ultrasonic Cleaning Module Kit (Purchased Separately)

2 Specifications

Table 1. Prism RT-50 Specifications

| ITEM | RT-50 PRISM |
|----------------------------|---|
| P/N | 10013 |
| RANGE OF MEASUREMENT | Refractive Index: 1.3200 – 1.4000 Brix: 0.00 – 38.00% Temperature: -20°C – 80°C |
| RESOLUTION | Refractive Index: 0.0001 Brix and other: 0.1% |
| ACCURACY | Refractive Index: ±0.0002 Brix and other: ±0.2% |
| SAMPLE TEMPERATURE | 14 – 131 °F (-10 - 55 °C) |
| MAX SAMPLE PRESSURE / FLOW | ≤142 psi (0.98 MPa) / <13.5 GPM (9.8 ft/s) |
| ENVIRONMENTAL TEMPERATURE | 14 – 104 °F (-10 – 40 °C) |
| WEIGHT | 3.2 pound (1.45 kg) |
| DIMENSION | 4.33 x 4.2 inch (110 x 107 mm) |
| PROTECTION | IP-67 |
| LIGHT SOURCE | LED |
| WET MATERIALS | Sapphire, 316L Stainless steel |
| SIGNAL OUTPUT | 2x 4-20 mA and RS-485 Modbus |
| POWER | 24 VDC (1.5W) |
| REGULATION | CE / RoHS Marked |

* With Pyxis's continuous improvement policy, these specifications are subject to change without notice.

3 Unpacking Instrument

Remove the instrument and accessories from the shipping container and inspect each item for any damage that may have occurred during shipping. Verify that all accessory items are included. If any item is missing or damaged, please contact Pyxis Lab Customer Service at service@pyxis-lab.com

3.1 Standard Accessories

RT-50 Prism Package (P/N 10013)

- The package should include one RT-50 Prism Refractive Index Sensor w/8Pin Female Cable
- One 316L Stainless Steel Tri-Clamp Flow Cell Assembly (P/N 56206)
- One MA-1.5CR Cable (1.5 Meter/ 4.9 ft 8Pin Male Adapter/Flying Lead) (P/N 50746)
- One Prism RT-Series Wall Outlet Power Supply Kit (110/220VAC/24VDC – 2Pin) (P/N 56207)



Figure 1. RT-50 Prism / Tri-Clamp Flow Cell Assembly / MA-1.5 Flying Lead Cable / 110/220VAC-24VDC Power Supply

Tri-Clamp Flow Assembly Side Diagram

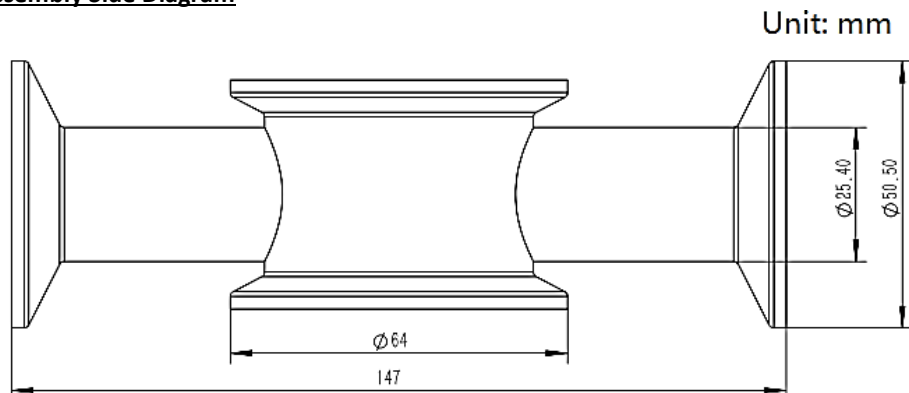

3.2 Optional Accessories

The following optional accessories can be ordered from Pyxis Customer Service (order@pyxis-lab.com) or Pyxis E-Store at <https://pyxis-lab.com/shop/>.

Table 2. Optional Accessories

| Optional / Replacement Accessories | Part Number (P/N) |
|--|-------------------|
| RT-Series Prism Wall Outlet Power Supply Adapter Kit <i>(Plug In Power Supply Kit - Converts Wall Outlet 110/220VAC to 24VDC for Prism RT-50)</i> | 56207 |
| MA-CR <i>(Bluetooth Adapter for 8-Pin Pyxis Sensors for use with uPyxis Mobile & Desktop)</i> | MA-CR |
| MA-NEB <i>(USB Bluetooth Adapter for PC to use uPyxis Desktop)</i> | MA-NEB |
| MA-50CR <i>(50' Extension Cable w/ 8-Pin Adapters)</i> | 50743 |
| Pyxis Probe Cleaning Kit | SER-01 |
| Tri-Clamp Flow Cell Assembly Complete Replacement | 56206 |
| Tri-Clamp Flow Cell Assembly Replacement Gasket Kit | 56209 |
| RT-Series Ultra-Sonic Cleaning Module Kit | 56208 |

4 Installation

4.1 Main Assembly

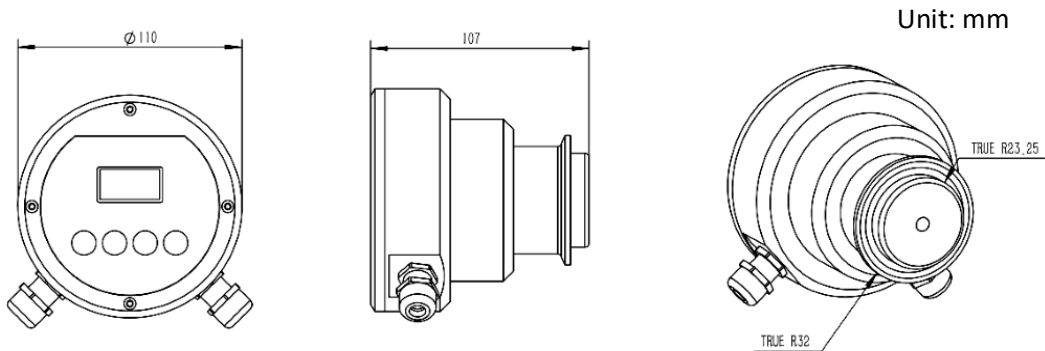

Figure 2. Prism RT-50 Sensor Dimensions (mm)

Each Prism RT-50 is provided with a 316L stainless steel Tri-Clamp Inline Flow Assembly with 3/4-inch FNPT inlet/outlet flanges. A flange and plug are also inserted into a portal opposite of the sensor eye for use with the RT-Series Ultrasonic Cleaning Module Kit (P/N 56208) in applications requiring automated inline cleaning.

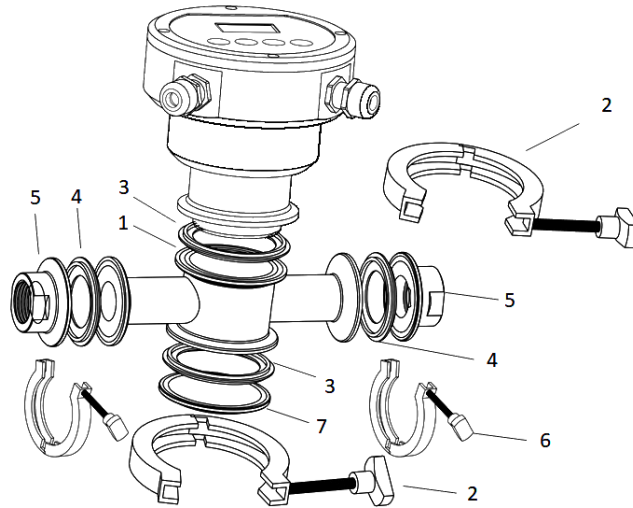

Figure 3. Tri-Clamp Flow Cell Assembly (P/N: 56206)

Table 3. Tri-Clamp Flow Cell Assembly Components

| ID # | Description |
|------|--|
| 1 | Flow cell with 2.5-inch Port for Prism RT-50 Sensor Head |
| 2 | Sensor Tri-Clamp 2.5-inch |
| 3, 4 | Tri-Clamp Flow Cell Gasket Kit (P/N: 56209) |
| 5 | 3/4-inch NPT Flange |
| 6 | Flange Tri-Clamp 2-inch |
| 7 | Plug Cap ϕ 64mm Reserved for Ultra-Sonic Cleaning |

4.2 Piping

The Prism RT-50 with Tri-Clamp Flow Cell Assembly should be installed per the diagram provided in Figure 4. Be sure to avoid installations illustrated in Figure 5.

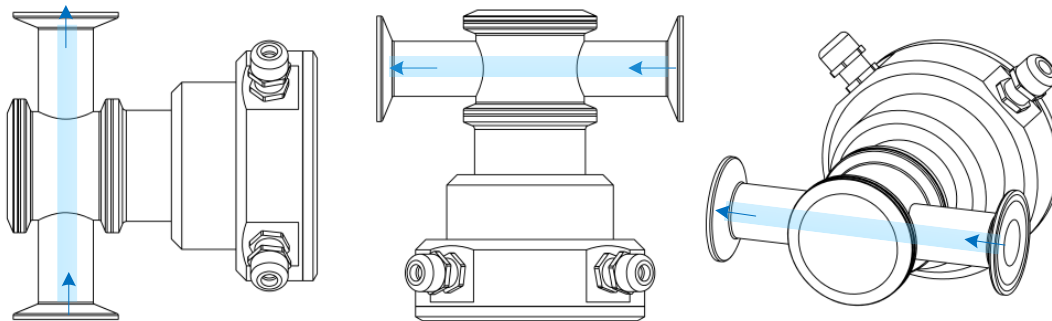

Figure 4. Correct Installations

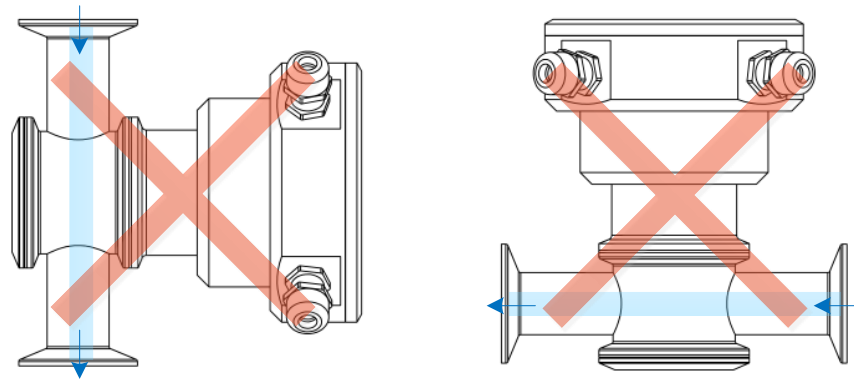

Figure 5. Incorrect Installations

4.3 Wiring

The Prism RT-50 unit offers two (2) cable points of attachment, both terminated with a unique connector (Figure 6). The Prism RT-50 may be powered via a direct 24VDC supply source (via 8-Pin cable provided with the Prism RT-50) or by the provided accessory called Prism RT-50 Wall Outlet Power Supply Adapter Kit (P/N 56207). Explanation of each option below:

Powered by a Direct 24VDC Power Source via 8-Pin Cable Provided with Prism RT-50

For applications where the Prism RT-50 is connected to and directly powered by 24VDC source (Controller, PLC, DCS etc.), the device should be connected via the 8-Pin Cable and MA-1.5CR Flying Lead Cable. These cables provide power as well as 4-20mA and RS-485 output communication to the connected device. Please refer to Table 4 for wire designations of the 8-pin cables.

Powered by a Prism RT-Series Wall Outlet Power Supply Adapter Kit

For applications desiring the Prism RT-50 to be powered by a standard 110/220VAC wall outlet, Pyxis offers the Prism RT-Series Wall Outlet Power Supply Kit (P/N: 56207). This kit offers a 2-Pin cable and wall outlet adapter for direct power supply from a standard 110/220VAC wall outlet. ***NOTE*** In the wall outlet powering format, there is no need to terminate the power supply portion of the 8-Pin Cable. This cable may continue to be used in order to pass 4-20mA and RS-485 output signals or for use with the MA-CR Bluetooth adapter for uPyxis® App access.

Table 4. Wire Designations

| Wire Color | Designation |
|------------|----------------------------|
| Red | 24V + |
| Brown | 24V Power ground |
| Gray* | 4–20mA - |
| White | nD/Brix/Others %, 4–20mA + |
| Pink | Temperature, 4–20ma + |
| Blue | RS-485 A |
| Yellow | RS-485 B |
| Green | RS-485 Ground |

* Gray Wire Internally connected to the power ground. 4-20mA is not loop powered.

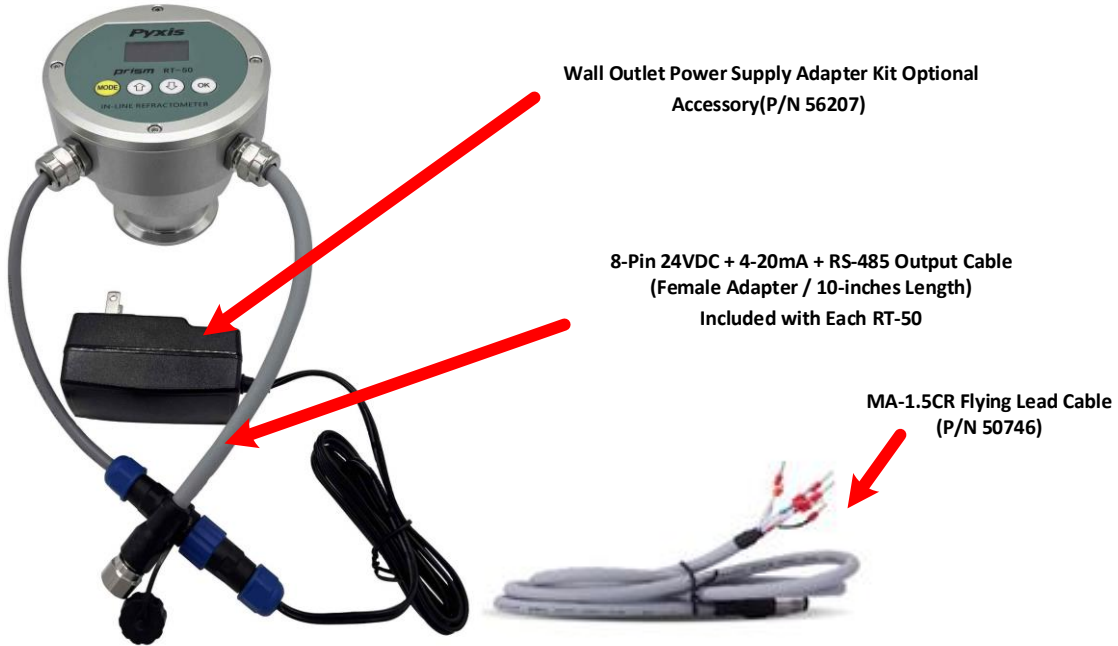

Figure 6. Prism RT-50 with RT-Series Wall Outlet Adapter Kit (P/N: 56207) and MA-1.5CR Flying Lead Cable (P/N: 50746)

5 Instrument Overview

5.1 Key Functions

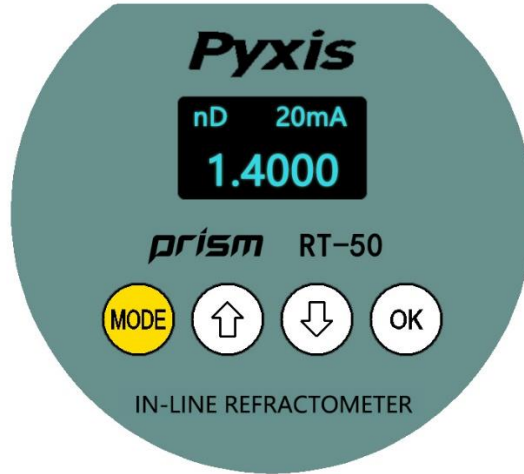



Figure 7. Prism RT-50 Main Display Screen

Table 5. Prism RT-50 Key Functions

| Key | Function Description |
|---------|--|
| MODE | Launch setup function associated with the current mode |
| ↑ and ↓ | Select measurement modes (units); select available selections associated |
| OK | Selection confirmation, (Press 3S to set the HOME  display) |

5.2 Measurement Modes

The Prism RT-50 measures the sample refractive index (nD) and temperature. Use the arrow keys to select the concentration units that are calculated from nD and the temperatures with using the pre-loaded equations for Brix. The main output of 4-20mA signal value switches with the display concentration selected per the 4-20mA output scales section 9.1 of this manual. ***NOTE*** To set the selected display as the DEFAULT display upon power-up after a power-loss, please Press and HOLD the selection confirmation for a period of 3-seconds. This will set the selected display as the default even during power cycles. If not, the unit will always revert back to nD (Refractive Index) upon power-up after a power-loss.



Figure 8. nD



Figure 9. Brix %

5.3 Sensitivity Setup

A higher sensitivity value set will result in a slower sensor response and the displayed value will show less fluctuation. For applications that require very accurate refractive index measurement, and the refractive index does not undergo any rapid changes in the time scale of minutes, the sensitivity should be set up to the highest value of 30.



Figure 7. – Sensitivity

5.4 Cleaning Cycle Setup

RT-50 supports an extended ultrasonic cleaning function using the RT-Series Ultra-Sonic Cleaning Module Kit (P/N 56208). When working in synchronization with the RT-Series Ultrasonic Cleaning Module, the working cleaning cycle is set by RT-50 in increments of every 5, 15 or 30 minutes for a cleaning duration of 5-seconds per cycle. The RT-50 default programmed cleaning time is every 15-minutes. For pricing, technical data and programming of the Ultra-Sonic Cleaning Module Kit, please contact order@pyxis-lab.com



Figure 8. – Programming the Clean Cycle Frequency

5.5 Reset Parameters

This mode will erase the user's calibration and setting information, restore the factory calibration and setting information, including air calibration, brix/liquid concentration offset calibration, sensitivity, etc.



Figure 9.



Figure 10.

6 Calibration

Calibration for refractive index is not required for the RT-50 use. The Prism RT-50 can however be calibrated in air to correct possible misalignment and aging of the optic components. An offset calibration for each concentration unit is provided by using a liquid sample with known concentration value.

6.1 Air Calibration of Refractive Index

1. Clean the Prism RT-50 sapphire lens with soft tissue.
2. If any tenacious deposits are present on the sensor lens, you may pre-soak the sensor lens in Pyxis Probe Cleaning Solution (P/N: SER-01) for 10–15 minutes, then rinse with clean water and wipe with soft tissue prior to proceeding to air calibration of refractive index.

NOTE Please refer to the Section 10.1 **Methods to Cleaning the Prism RT-50** for details.

3. After properly cleaning the sensor lens, remove any residual liquid from the sapphire lens.
4. Shield the lens from the ambient light.
5. Press the **MODE** key on the face of the unit to launch the air calibration interface (Figure 14).
6. Hold the **OK** key on the face of the unit for 3 seconds to start the air calibration process (Figure 15).
7. Once the calibration is complete, press the **MODE** key to return to measurement mode (Figure 16).



Figure 11.



Figure 12.

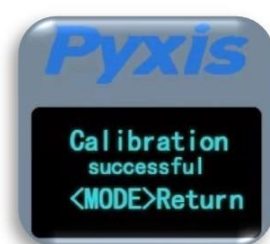

Figure 13.

6.2 Brix and Other Liquid Concentration Offset Calibration

The refractive index value does not require calibration as stated in Section 6.1. The refractive index and temperature values are internally converted to the desired liquid concentration unit selected through the display of the sensor interface. This displayed liquid concentration unit value may be calibrated to a known solution if desired. To do this:

1. Place the Prism RT-50 in the calibration liquid of a known concentration making sure the sensor is covered from ambient light.
2. Use the **arrow** keys on the sensor display to select the corresponding concentration unit of your sample. (ie. Brix)
3. Press the **MODE** key on the sensor display to launch the offset calibration interface for the specific concentration unit selected.
4. Proceed through the screen prompt steps to calibrate unit to the known concentration of liquid standard.



Figure 14.

7 Setup and Configuration with uPyxis® Mobile App

7.1 Download uPyxis® Mobile App

Download uPyxis® Mobile App from [Apple App Store](#) or [Google Play](#).



Figure 18. uPyxis® Mobile App installation

7.2 Connecting to uPyxis® Mobile App via Bluetooth

Connect the Prism RT-50 to the Pyxis MA-CR Bluetooth adapter (P/N MA-CR) and a controller or PLC with a 24 VDC power source according to the figures below. Figure 19 shows that the Prism RT-50 is powered by a controller through the 8-Pin cable provided with the Prism RT-50.

NOTE uPyxis® Mobile allows mobile devices to wirelessly speak directly to the MA-CR Bluetooth Adapter. uPyxis® Desktop requires MA-NEB (USB Bluetooth adapter) to be installed in the PC for wireless access to MA-CR.

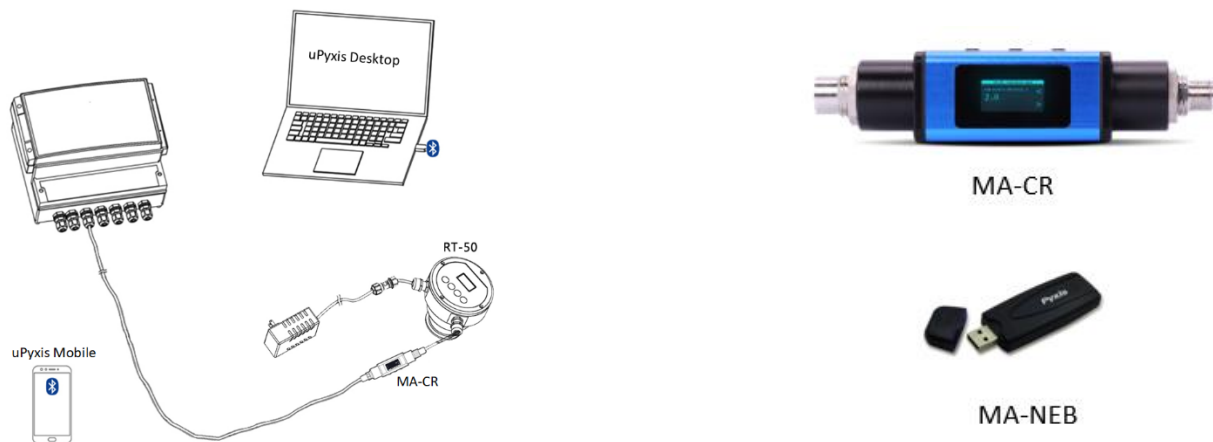

Figure 19. 24VDC Powered via Controller through 8-Pin Cable and MA-CR Bluetooth Adapter

1. Install the MA-CR Bluetooth Adapter on the 8Pin output cable from the RT-50 as outlined above.
2. Open the **uPyxis®** Mobile App.
3. In the **uPyxis®** Mobile App, swipe down with finger on the main screen to refresh the list of available Pyxis devices.
NOTE this may take multiple finger swipes for Bluetooth to connect to the device.
4. If the connection is successful, the Prism RT-50 and its Serial Number (S/N) will be displayed (Figure 20).
5. Press on the **Prism RT-50 sensor image**.

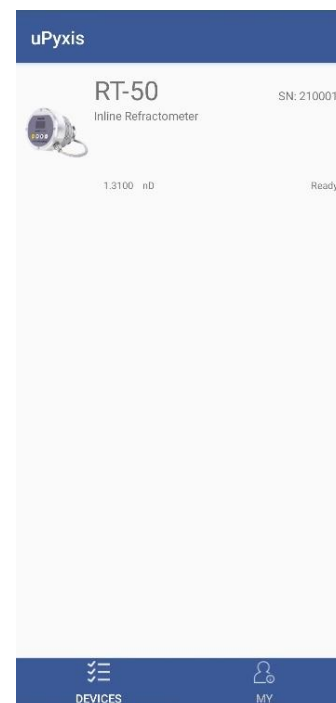

Figure 15. – Discovered RT-50 on uPyxis Mobile APP

7.3 Calibration Screen and Reading

When connected, the uPyxis® Mobile App will default to the **Calibration** screen. From the **Calibration** screen, the user can perform the various forms of calibrations as discussed in this manual (see Sections 6.1 and 6.2) by pressing on **Air Calibration** and **Bias Calibration (Offset Calibration)**. The calibration objective is determined by the drop-down box selected. Follow the screen instructions for each calibration step.

The user may also perform a factory reset of all calibration values saved in the device by pressing **Restore Factory** and entering "upyxis" into the prompt.

Setting 4-20mA Range The 4-20mA output range for any concentration scale may be modified by the user, if the default range is not suitable for you. This feature enables the user to adjust the 4-20mA output values of the RT-50 for the concentration curve as desired. ***NOTE*** 20mA value adjustment must be *LESS* than the highest default 20mA output value of the concentration selected. (ie. for BRIX concentration, the 20mA value may be set to 38% or lower). Please refer to Section 9.1 for default 4-20mA output scales of the RT-50.

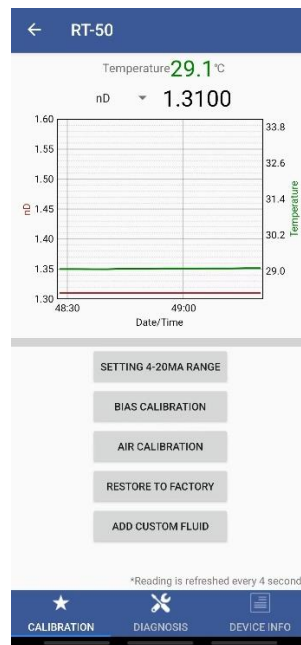

Figure 16. – Calibration Screen Interface uPyxis Mobile APP.

7.4 Add/Modify Custom Fluid

In order to adapt to more application scenarios, users can create and add new customized fluids through the uPyxis APP and display them on the OLED screen. This method will establish a formula between the new fluid and Brix%, and the accuracy can reach $\pm 0.2\%$. Modification of the Custom Fluid Name and Coefficient are also supported via uPyxis.

STEP 1 - Name the Custom (New) Fluid

The name should not exceed 7 characters in length. ***NOTE*** Only alphanumeric and “_” may be used.

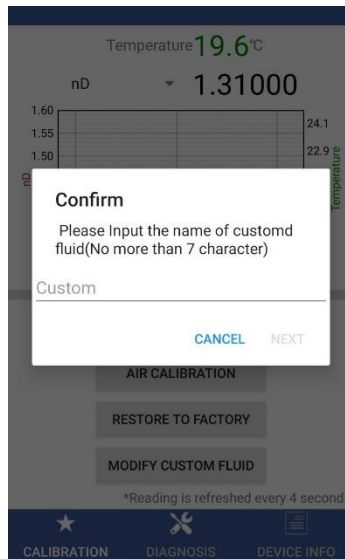

Figure 17.

STEP 2 - Entering at Least 5-sets of Custom Product Concentration Data

The user should then enter at least 5-sets of the Custom (New) Fluid Concentration (%) and to the corresponding Brix (%) concentration already populated in the table. The uPyxis App will calculate and establish the coefficient formula between the Custom (New) Fluid Concentration (%) and Brix (%). ***NOTE*** If your data correlation coefficient R^2 is less than 0.8, the uPyxis APP will **NOT** permit you to proceed to the next step and users must check their concentration data for accuracy.

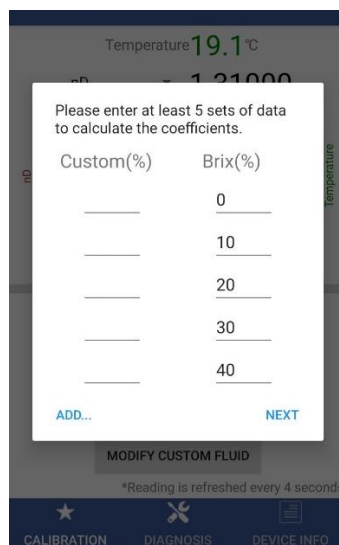

Figure 18.

STEP 3 - Set Custom (New) Fluid 4-20mA Range & Sensor Output Scale

According to the concentration range of the Custom (New) Fluid, enter the appropriate concentration (%) of 4mA, and concentration (%) of 20mA to program the 4-20mA output scale from the sensor. ***NOTE*** It is important to remember this output scale for programming the signal receiving device accurately (ie. Controller, PLC or Network)

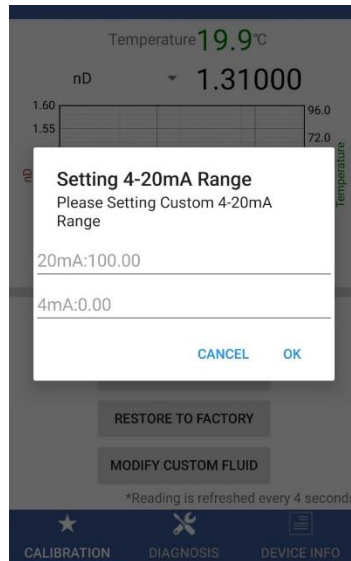

Figure 19.

STEP 4 - Apply the Custom (New) Fluid Settings and Display

Please confirm whether to apply this custom fluid and display it on the OLED screen. Once OK is pressed, the uPyxis APP will apply this customized firmware to the RT-50 process control board and the unit is now set to display your custom fluid.

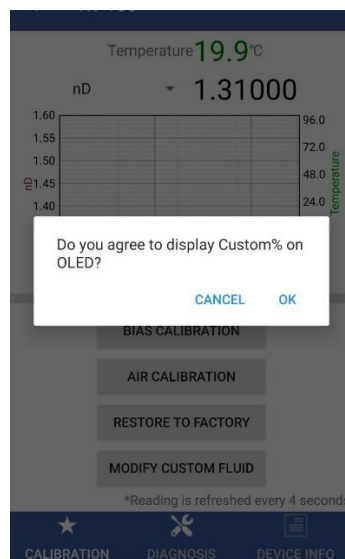

Figure 20.

7.5 Diagnosis Screen

From the **Diagnosis** screen within uPyxis, the user can check the sensors diagnosis condition. This feature may be used for technical support when communicating with service@pyxis-lab.com

The user can choose the time period of data export, including: hour, day, week, half month, and all data stored. After selecting the time, press **Export History Data** and wait for the progress bar to load.

NOTE The Prism RT-50 is programmed to store data at a frequency of once per minute with a maximum of 56 days storage capacity.

The **Diagnosis** screen functions are described in table below:

Table 6. – Diagnosis Screen Functions

| Function | Description |
|---------------------|---|
| Wipe History Data | It is convenient to clear unnecessary historical data. This process is relatively slow. Do not power off during the process. |
| Export Spectrum | Derive the original spectrum. |
| Export History Data | The historical data is exported and saved in CSV format. The storage contents include refractive index nD, temperature °C, Brix, and others. |
| Save & Share | Save the data and send it to other software. |
| Hour (Dropdown) | Select the length of time to export data. The latest hour is exported by default. Users may select Day, Week, and Half-Month. Data can be exported for up to 56 days. |

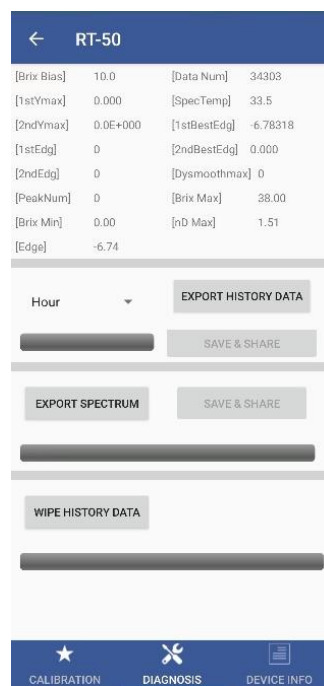

Figure 21. – Diagnosis Screen Interface and Exporting Historical Data

7.6 Device Info Screen

From the **Device Info** screen. You can name the Device or Product as well as set the Modbus address.

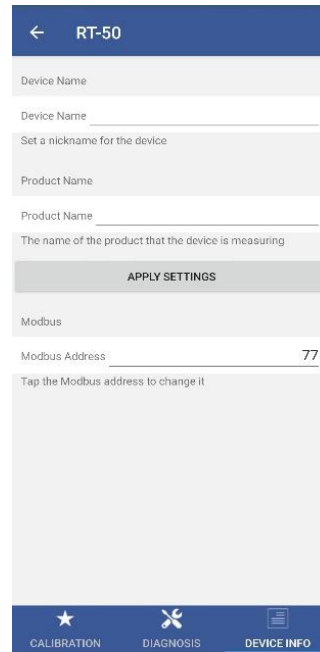

Figure 22. – Device Info Screen Interface

8 Setup and Calibration with uPyxis® Desktop App

8.1 Install uPyxis® Desktop App

Download the latest version of **uPyxis®** Desktop software package from: <https://upyxis.pyxis-lab.com.cn/release/pc/uPyxis.Setup-latest.zip>

This setup package will download and install the Microsoft.Net Framework 4.5 (if not previously installed on the PC), the USB driver for the USB-Bluetooth Adapter (MA-NEB), the USB-485 Adapter (MA-485), and the main **uPyxis®** Desktop application. Double click the **uPyxis.Setup.exe** file to install.

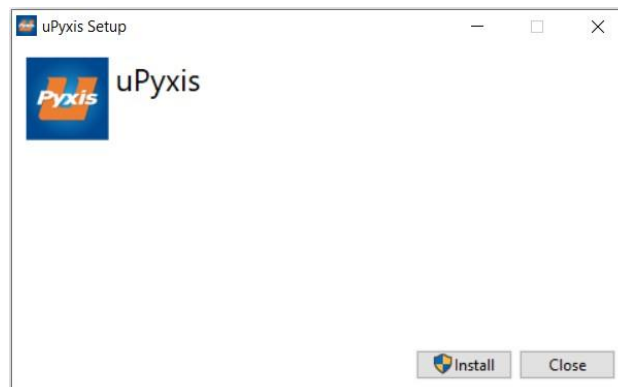

Figure 23. uPyxis® Desktop App installation

Click **Install** to start the installation process. Follow the screen instructions to complete the USB driver and **uPyxis®** installation.

8.2 Connecting to uPyxis® Desktop App via USB-C Cable

For those desiring not to use wireless connection to uPyxis, the MA-CR Bluetooth adapter (P/N: MA-CR) can be used to connect an RT-50 sensor to a laptop or a desktop computer with a USB-C cable and the **uPyxis®** Desktop App. In this format, the power should be sourced from the laptop via the USB-C cable connected to the MA-CR and Laptop USB-C port.

- 1) Download and install uPyxis Desktop APP from <https://upyxis.pyxis-lab.com.cn/release/pc/uPyxis.Setup-latest.zip>
- 2) Connect a USB Type-C cable to the port at the bottom of the MA-CR and to the USB port of the laptop or computer. This will provide power the MA-WB from the laptop/computer. Connect the MA-CR to the RT-50 sensor. The MA-CR Bluetooth adapter will boost the 5V of the regular USB to 24V to power the sensor for use with uPyxis Desktop App.



MA-CR Bluetooth Adapter – Bottom USB-C

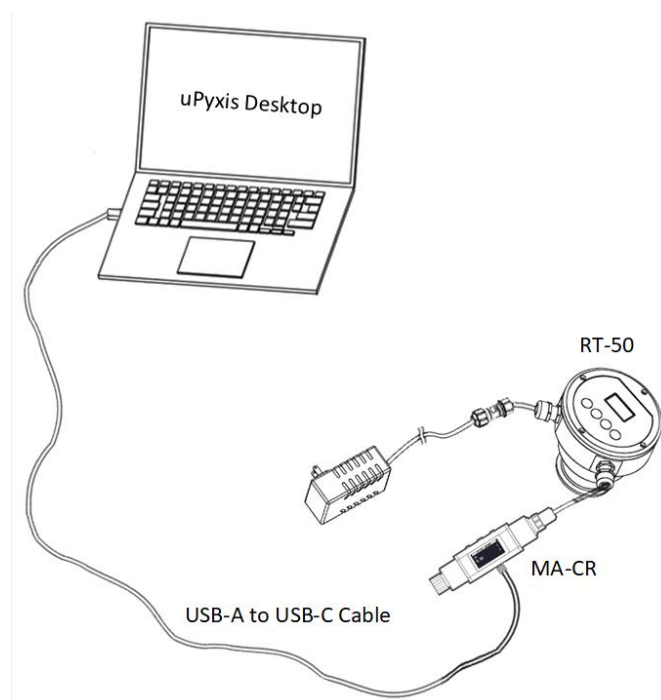

Figure 29. – MA-CR Adapter Connected via USB-C to Laptop for uPyxis Desktop Use

- 3) Set the MA-CR to operate in USB Mode by following the steps below.
 - a. Once the MA-CR screen is powered Press ◀ or ▶ until you arrive at (USB to RS485) screen.
 - b. Press the **OK** Button.
 - c. Follow Prompts below to Enable USB feature. Once enabled, you may connect to uPyxis.



- 4) Open the desktop uPyxis APP.
- 5) Click Device to launch the connection option menu.
- 6) Select Connect via USB-RS485 (Figure 30).
- 7) Select the Comm Port to make a connection. Normally only one Comm port is identified by uPyxis. If more than one Comm port listed in the selection dropdown, you may try to select each one to see if a connection can be made. Alternatively, you may use the Windows Device Manager to identify the Comm Port that the Pyxis USB adapter is using.

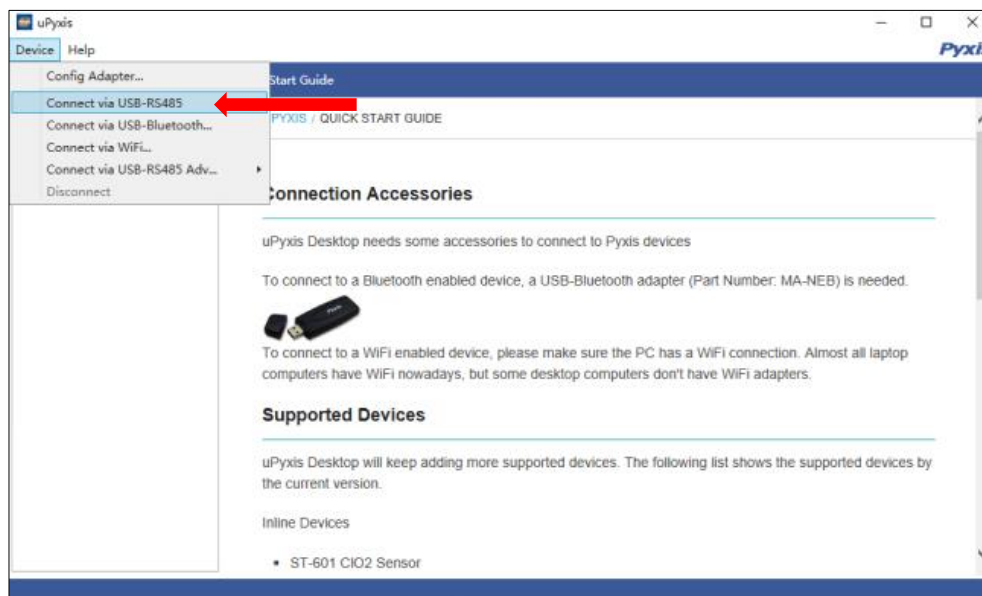

Figure 30. - Connect to RT-50 via USB-RS485 option

8.3 Information Screen

Once connected to the device, a picture of the device will appear on the top left corner of the window and the **uPyxis®** Desktop App will default to the **Information** screen. On the **Information** screen you can set the information description for **Device Name**, **Product Name**, and **Modbus Address**, then click **Apply Settings** to save.

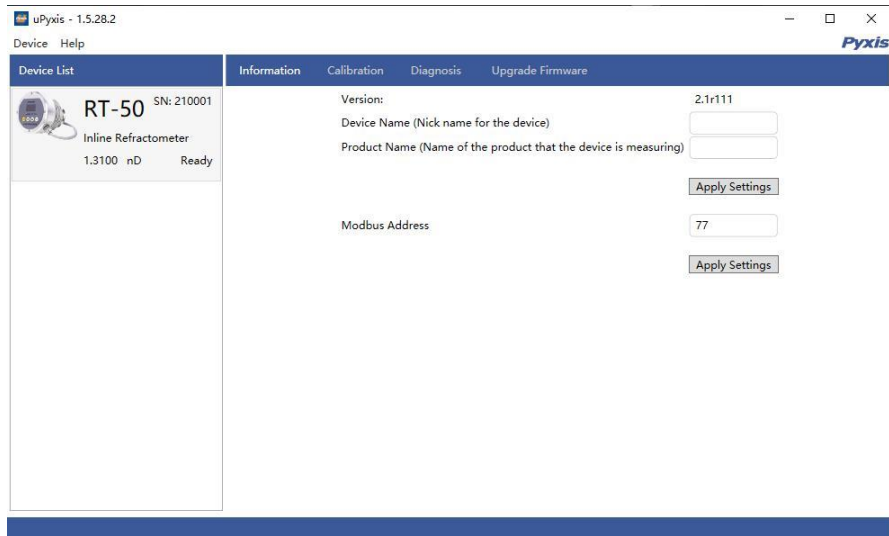

Figure 24. – Information Screen uPyxis Desktop

8.4 Calibration Screen

To calibrate the device, click on **Calibration**. From the **Calibration** screen, the user can perform the various forms of calibrations as discussed in this manual (see Sections 6.1 and 6.2) by pressing on **Air Calibration** and **Bias Calibration (Offset Calibration)**. The calibration objective is determined by the drop-down box selected. Follow the screen instructions for each calibration step.

The user may also perform a factory reset of all calibration values saved in the device by pressing **Restore Factory** and entering 'upyxis' into the prompt.

Setting 4-20mA Range The 4-20mA output range for any concentration scale may be modified by the user, if the default range is not suitable for you. This feature enables the user to adjust the 4-20mA output values of the RT-50 for the concentration curve as desired. ***NOTE*** 20mA value adjustment must be LESS than the highest default 20mA output value of the concentration selected. (ie. for BRIX concentration, the 20mA value may be set to 38% or lower). Please refer to Section 9.1 for default 4-20mA output scales of the RT-50.

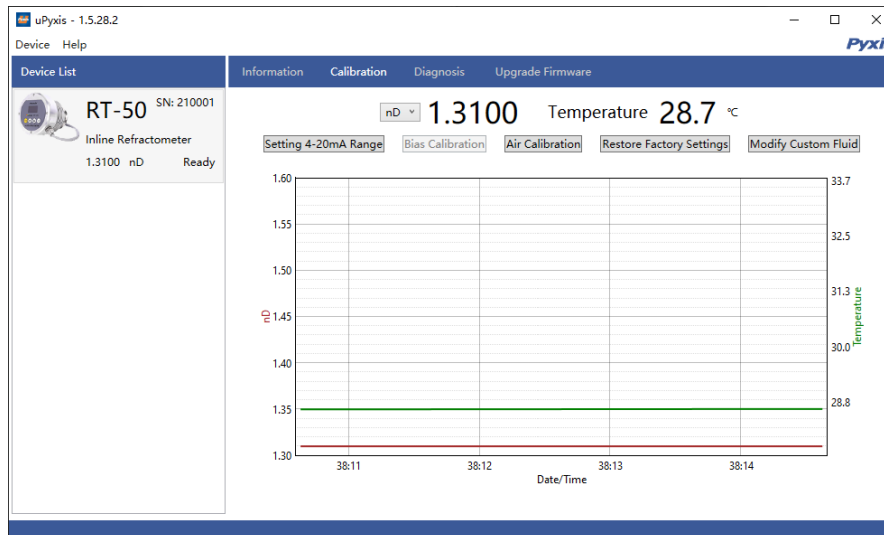

Figure 25.

8.5 Add/Modify Custom Fluid

In order to adapt to more application scenarios, users can add new fluids through uPyxis and display them on the OLED screen. This method will establish a formula between the new fluid and Brix%, and the accuracy can reach $\pm 0.2\%$. Modification of the Custom Fluid Name and Coefficient are also supported via uPyxis.

STEP 1 - Name the Custom (New) Fluid

The name should not exceed 7 characters in length. ***NOTE*** Only alphanumeric and “_” may be used.

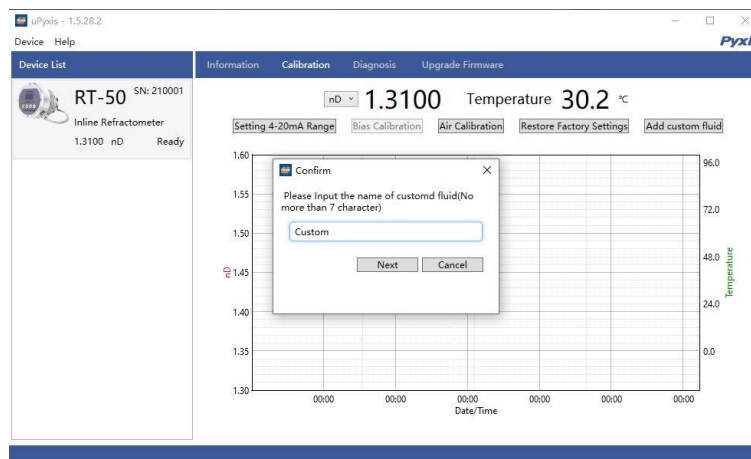

Figure 26.

STEP 2 - Entering at Least 5-sets of Custom Product Concentration Data

The user should then enter at least 5-sets of the Custom (New) Fluid Concentration (%) and to the corresponding Brix (%) concentration already populated in the table. The uPyxis App will calculate and establish the coefficient formula between the Custom (New) Fluid Concentration (%) and Brix (%). ***NOTE*** If your data correlation coefficient R^2 is less than 0.8, the uPyxis APP will **NOT** permit you to proceed to the next step and users must check their concentration data for accuracy.

The screenshot shows a dialog box titled 'Please enter at least 5 sets of data to calculate the coefficients.' It contains two columns of input fields: 'Brix(%)' and 'Custom(%)'. The 'Custom(%)' column has pre-filled values: 0, 10, 20, 40, and 60. The 'Brix(%)' column has empty input fields. At the bottom, there are 'Add...' and 'Next' buttons.

Figure 27.

STEP 3 - Set Custom (New) Fluid 4-20mA Range & Sensor Output Scale

According to the concentration range of the Custom (New) Fluid, enter the appropriate concentration (%) of 4mA, and concentration (%) of 20mA to program the 4-20mA output scale from the sensor. ***NOTE*** It is important to remember this output scale for programming the signal receiving device accurately (ie. Controller, PLC or Network)

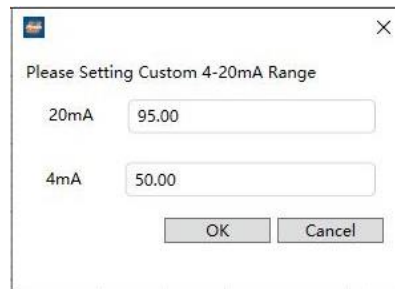

Please Setting Custom 4-20mA Range

20mA 95.00

4mA 50.00

OK Cancel

Figure 28.

STEP 4 - Apply the Custom (New) Fluid Settings and Display

Please confirm whether to apply this custom fluid and display it on the OLED screen. Once OK is pressed, the uPyxis APP will apply this customized firmware to the RT-50 process control board and the unit is now set to display your custom fluid.



Do you agree to display Custom% on OLED?

Yes No

Figure 29.

8.6 Diagnosis Screen

From the **Diagnosis** screen, the user can check the diagnosis condition. This feature may be used for technical support when communicating with service@pyxis-lab.com

The user can choose the time period of data export, including: hour, day, week, half month, and all data stored. After selecting the time, press **Export History Data** and wait for the progress bar to load.

NOTE The Prism RT-50 is programmed to store data at a frequency of once per minute with a maximum of 56 days storage capacity.

The **Diagnosis** screen's functions are described in table below:

Table 7.

| Function | Description |
|---------------------|---|
| Wipe History Data | It is convenient to clear unnecessary historical data. This process is relatively slow. Do not power off during the process. |
| Export Spectrum | Derive the original spectrum. |
| Export History Data | The historical data is exported and saved in CSV format. The storage contents include refractive index nD, temperature °C, Brix and other. |
| Save & Share | Save the data and send it to other software. |
| Hour (Dropdown) | Select the length of time to export data. The latest hour is exported by default. Users may select Day, Week, and Half-Month. Data can be exported for up to 56 days. |

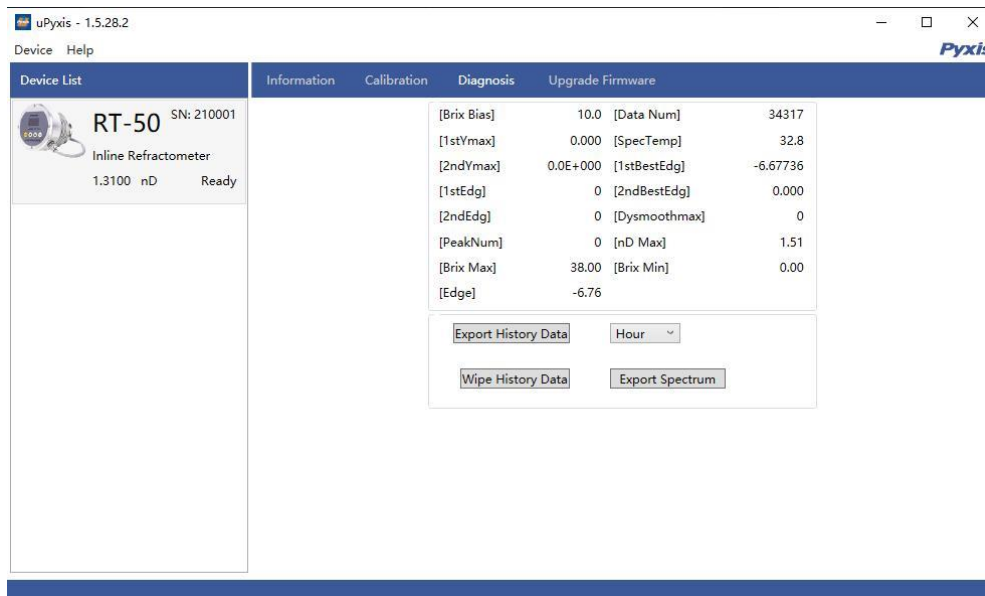

Figure 30.

9 Outputs

9.1 4–20mA Output Setup

The 4 ~ 20mA range can be modified by uPyxis, if the default range is not suitable (refer to Calibration Sections 7.3 and 8.4 of this manual). The 4–20mA default output of the Prism RT-50 sensor is scaled as outlined below.

Table 8.

| Measurement Mode | 4 mA Output Value | 20 mA Output Value |
|-----------------------|---------------------------|-----------------------------|
| Refractive Index (nD) | 1.3000 | 1.4000 |
| Brix (%) | 0% | 38% |
| Custom Fluid (%) | 0% <i>User Defined</i> | 100% <i>User Defined</i> |
| Temperature | -20 °C | 80 °C |

9.2 Communication using Modbus RTU

The Prism RT-50 sensor is configured as a Modbus slave device. In addition to the nD, %Bx and temperature values, many operational parameters, including warning and error messages, are available via a Modbus RTU connection. Contact Pyxis Lab Customer Service service@pyxis-lab.com for more information.

10 Sensor Maintenance and Precaution

10.1 Methods to Cleaning the Prism RT-50

For most RT-50 sensor cleanings, the sapphire lens should be rinsed with clean or DI water than wiped clean with a soft tissue. If tenacious inorganic deposits are present on the sapphire lens, soak the lower half of the Prism RT-50 sensor in 100 mL of Pyxis inline sensor cleaning solution (SER-01) for 15-minutes. If the surface is not entirely clean, continue to soak the sensor for an additional time until clean. Lightly wipe the sensor lens with a soft tissue. Rinse sensor eye with clean or DI water. Pyxis Lab Inline Sensor Cleaning Solution can be purchased at our online E-Store/Catalog at <https://pyxis-lab.com/product/probe-cleaning-kit/>



Figure 31. Inline Probe Cleaning Solution Kit (P/N: SER-01)

11 Contact Us

Pyxis Lab, Inc

1729 Majestic Dr. Suite 5

Lafayette, CO 80026 USA

www.pyxis-lab.com

Phone: +1 (866) 203-8397

Email: service@pyxis-lab.com