

**Pyxis®**

**prism**

# **PRISM™ RT-200 Refractometer**

*Inline Refractometer for High Temperature/Pressure Applications*

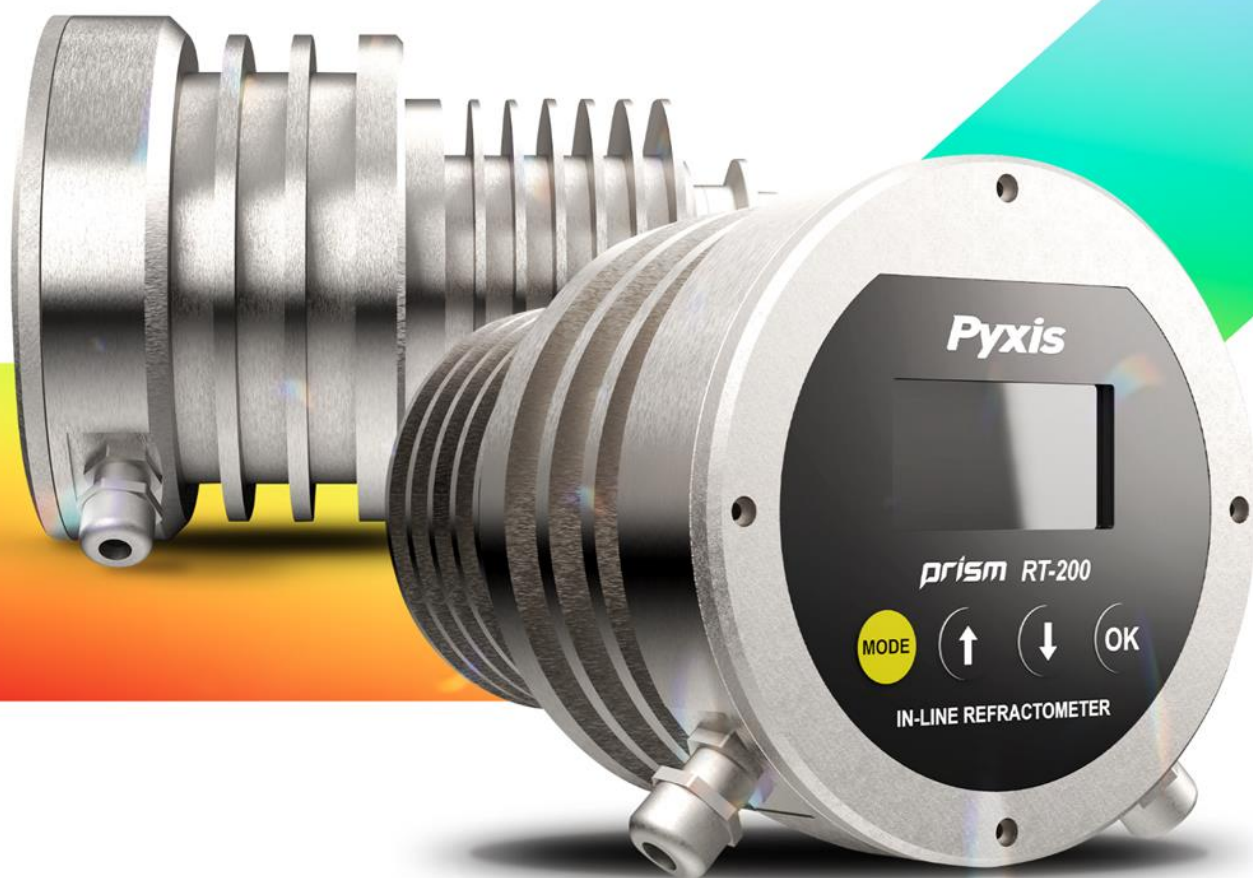

**Pyxis Lab® Inc.**

21242 Spell Circle  
Tomball, TX 77375  
www.pyxis-lab.com

**USER MANUAL**

## Table of Contents

1	Introduction .....	5
1.1	Main Features .....	5
2	Specifications .....	6
3	Unpacking the RT-200 .....	7
3.1	Standard Accessories .....	7
3.2	Optional Accessories .....	8
4	Installation.....	8
4.1	Main Assembly.....	8
4.2	Piping & Flow Parameters.....	10
4.3	RT-200 Wiring.....	11
5	Instrument Overview .....	13
5.1	Key Functions .....	13
5.2	Measurement Modes.....	14
5.3	Sensitivity Setup.....	15
5.4	Cleaning Cycle Setup .....	15
5.5	Reset Parameters .....	15
6	Calibration.....	16
6.1	Air Calibration of Refractive Index .....	16
6.2	Brix and Other Liquid Concentration Offset Calibration .....	17
7	Setup and Configuration with uPyxis® 2.0 Mobile App .....	18
7.1	Download uPyxis® 2.0 Mobile App .....	18
7.2	Connecting to uPyxis® 2.0 Mobile App via Built-in Bluetooth .....	18
7.3	Trend Chart .....	19
7.4	Device Configuration .....	20
7.5	Add/Set Custom Fluid .....	21
7.6	Diagnosis Screen .....	23
7.7	Data log Screen .....	24

8	Setup and Calibration with uPyxis® Desktop App.....	25
8.1	Install uPyxis® Desktop App .....	25
8.2	Connecting to uPyxis® Desktop App via USB-C Cable .....	26
8.3	Information Screen .....	28
8.4	Calibration Screen .....	29
8.5	Add/Modify Custom Fluid .....	30
8.6	Diagnosis Screen .....	32
8.7	Upgrade Firmware .....	33
9	4-20mA Outputs.....	34
9.1	4–20mA Output Setup .....	34
9.2	Communication using Modbus RTU.....	34
9.3	Communication with Bluetooth.....	34
10	Sensor Maintenance and Precaution .....	35
10.1	Methods to Cleaning the Prism RT-200 .....	35
11	Contact Us .....	35

## **Warranty Information**

### **Confidentiality**

The information contained in this manual may be confidential and proprietary and is the property of Pyxis Lab, Inc. Information disclosed herein shall not be used to manufacture, construct, or otherwise reproduce the goods described. Information disclosed herein shall not be disclosed to others or made public in any manner without the express written consent of Pyxis Lab, Inc.

### **Standard Limited Warranty**

Pyxis Lab warrants its products for defects in materials and workmanship. Pyxis Lab will, at its option, repair or replace instrument components that prove to be defective with new or remanufactured components (i.e., equivalent to new). The warranty set forth is exclusive and no other warranty, whether written or oral, is expressed or implied.

### **Warranty Term**

The Pyxis warranty term is thirteen (13) months ex-works. In no event shall the standard limited warranty coverage extend beyond thirteen (13) months from original shipment date.

### **Warranty Service**

Damaged or dysfunctional instruments may be returned to Pyxis for repair or replacement. In some instances, replacement instruments may be available for short duration loan or lease.

Pyxis warrants that any labor services provided shall conform to the reasonable standards of technical competency and performance effective at the time of delivery. All service interventions are to be reviewed and authorized as correct and complete at the completion of the service by a customer representative, or designate. Pyxis warrants these services for 30 days after the authorization and will correct any qualifying deficiency in labor provided that the labor service deficiency is exactly related to the originating event. No other remedy, other than the provision of labor services, may be applicable.

Repair components (parts and materials), but not consumables, provided during a repair, or purchased individually, are warranted for 90 days ex-works for materials and workmanship. In no event will the incorporation of a warranted repair component into an instrument extend the whole instrument's warranty beyond its original term.

### **Warranty Shipping**

A Return Material Authorization (RMA) Number must be obtained from Pyxis Technical Support before any product can be returned to the factory. Pyxis will pay freight charges to ship replacement or repaired products to the customer. The customer shall pay freight charges for returning products to Pyxis. Any product returned to the factory without an RMA number will be returned to the customer. To receive an RMA you can generate a request on our website at [Request Return or Repair - Pyxis Lab, Inc. \(pyxis-lab.com\)](https://www.pyxis-lab.com)

### **Pyxis Technical Support**

Contact Pyxis Technical Support at +1 (866) 203-8397 ext 2 or at [service@pyxis-lab.com](mailto:service@pyxis-lab.com)

## 1 Introduction

The Pyxis Prism RT-200 is an online digital refractometer that measures the refractive index of a liquid sample. This sensor provides a direct reading of highly accurate concentration values for a wide variety of water and process related applications. RT-200 is particularly suitable for sugar production and other high-temperature processes. It is a stand-alone device capable of self-sustained operation, live data display, and data logging. The Prism RT-200 also offers fully integrated 4-20mA and RS-485 Modbus output signals for connectivity to any microprocessor-based controller, display, PLC, or DCS network. The Prism RT-200 has built-in temperature-dependent equations to convert the measured sample temperature and refractive index to the percentage concentration of Mono Ethylene Glycol (MEG), Mono Propylene Glycol (MPG), Sugar Content (Brix) and Advanced Low Viscosity Fluid (ALV). Built-in Bluetooth makes it easier to connect to your phone. Additional concentration curves can be added via uPyxis APP.



**\*NOTE\*** *The Prism RT-200 is a very robust sensor and capable of operating in contaminated fluid samples. It is important, however, to note that users should take all precautions to prevent and filter suspended solids from the sample stream prior to the sensor to avoid tenacious deposit build-up on the sensor eye. In highly fouled applications, Pyxis recommends users conduct sensor eye cleaning on a regular basis. Pyxis Lab offers the Ultra-Sonic RT-Series Cleaning Module Kit (P/N 56208) for installation into the Tri-Clamp Flow Cell Assembly as an optional accessory allowing for automated online cleaning of the RT-200 refractive index sensor. Contact [www.order@pyxis-lab.com](mailto:www.order@pyxis-lab.com) for technical and pricing details of this online cleaning accessory.*

### 1.1 Main Features

- 4-20mA output of sample temperature and the displayed unit selected via the screen interface.
- RS-485 Modbus RTU output of temperature, refractive index and other diagnosis parameters.
- Built-in temperature dependent equations % BRIX, % MPG, % PEG, % ALV, %ALV+ and %GEO.
- Local Large Screen Display and historical data log saved in the unit programmable via **uPyxis®** App.
- Sturdy 316L stainless steel construction and suitable for harsh application environments.
- Convenient stainless-steel Tri-Clamp Tee with 3/4-inch NPT Flange for Easy Install and Removal.
- Built-In Bluetooth for easier setup and diagnosis via uPyxis APP
- Additional concentration curves can be added via uPyxis APP.

## 2 Specifications

**Table 1.** Prism RT-200 Specifications

ITEM	RT-200 PRISM
P/N	57124
RANGE OF MEASUREMENT	Refractive Index: 1.31700 – 1.5100 Brix: 0.00 – 85.00% Mono Ethylene Glycol: 0.00 – 100.00% Mono Propylene Glycol: 0.00 – 100.00% Advanced Low Viscosity Fluid: 0.00 – 100.00% Temperature: -20°C – 150°C
RESOLUTION	Refractive Index: 0.00001 Brix and Glycol: 0.01%
ACCURACY	Refractive Index: ±0.00001 Brix and Glycol: ±0.01%
SAMPLE TEMPERATURE	-4 –248 °F (-20 – 120 °C)
MAX SAMPLE PRESSURE / FLOW	≤142 psi (0.98 MPa) / <13.5 GPM (9.8 ft/s)
ENVIRONMENTAL TEMPERATURE	14 –113 °F (-10 – 45 °C)
WEIGHT	5.73 pound (2.6 kg)
DIMENSION	5.51x 7.67 inch (140 x 195 mm)
PROTECTION	IP-67
LIGHT SOURCE	LED
WET MATERIALS	Sapphire, 316L Stainless steel
SIGNAL OUTPUT	2x 4-20 mA and RS-485 Modbus Bluetooth 5.0
POWER	24 VDC (1.5W)
REGULATION	CE / RoHS Marked

\* With Pyxis's continuous improvement policy, these specifications are subject to change without notice.

### 3 Unpacking the RT-200

Remove the instrument and accessories from the shipping container and inspect each item for any damage that may have occurred during shipping. Verify that all accessory items are included. If any item is missing or damaged, please contact Pyxis Lab Customer Service at [service@pyxis-lab.com](mailto:service@pyxis-lab.com).

#### 3.1 Standard Accessories

RT-200 Prism Package (P/N 57124) will include the following:

- The package should include one RT-200 Prism Refractive Index Sensor w/8Pin Female Cable
- One 316L Stainless Steel Tri-Clamp Flow Cell Assembly (P/N 56206)
- One MA-1.5CR Cable (1.5 Meter/ 4.9 ft 8Pin Male Adapter/Flying Lead) (P/N 50746)
- One Prism RT-Series Wall Outlet Power Supply Kit (110VAC/24VDC – 2Pin) (P/N 56207)



**Figure 1.** RT-200 Prism / Tri-Clamp Flow Cell Assembly / MA-1.5 Flying Lead Cable / 110VAC-24VDC Power Supply

#### Tri-Clamp Flow Assembly Side Diagram

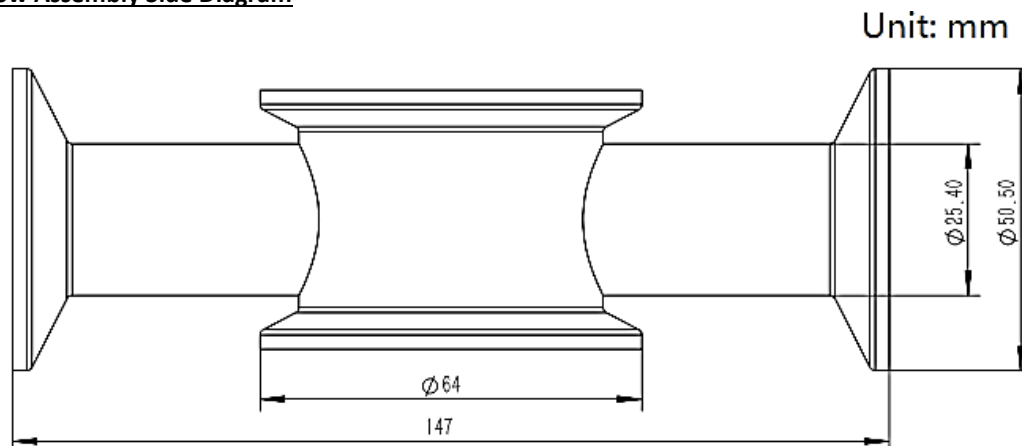

### 3.2 Optional Accessories

The following optional accessories can be ordered from Pyxis Customer Service ([order@pyxis-lab.com](mailto:order@pyxis-lab.com)), your preferred Pyxis Lab Distributor or on the Pyxis E-Store at [Better Water Tools | Analytical Inline & Handheld Devices | Pyxis Lab, Inc. \(pyxis-lab.com\)](#)

**Table 2. Optional Accessories**

Optional / Replacement Accessories	Part Number (P/N)
Prism RT-Series Wall Outlet Power Supply Adapter Kit <i>(Plug In Power Supply Kit - Converts Wall Outlet 110VAC to 24VDC for Prism RT-200 —2-Pin)</i>	56207
MA-CR <i>(Bluetooth Adapter for 8-Pin Pyxis Sensors for use with uPyxis Mobile &amp; Desktop)</i>	MA-CR
MA-NEB <i>(USB Bluetooth Adapter for PC to use uPyxis Desktop)</i>	MA-NEB
MA-50CR <i>(50' Extension Cable w/ 8-Pin Adapters)</i>	50743
Pyxis Probe Cleaning Kit	SER-01
Tri-Clamp Flow Cell Assembly Complete Replacement	56206
Tri-Clamp Flow Cell Assembly Replacement Gasket Kit	56209
Ultra-Sonic RT-Series Cleaning Module Kit	56208

## 4 Installation

### 4.1 Main Assembly

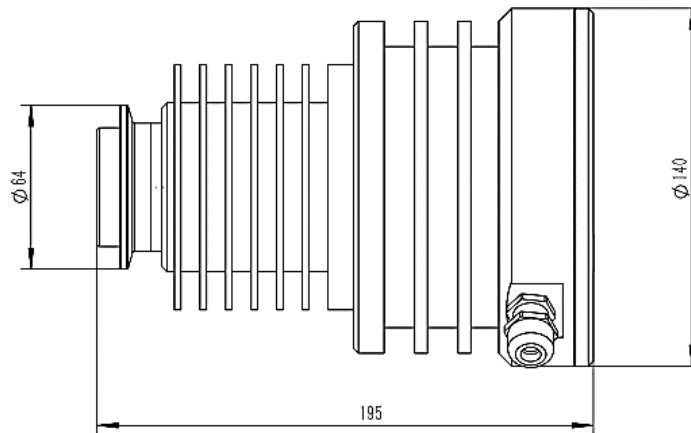

**Figure 2. Prism RT-200 Sensor Dimensions (mm)**

Each Prism RT-200 is provided with a 316L stainless steel Tri-Clamp Inline Flow Assembly with 3/4-inch FNPT inlet/outlet flanges. A flange and plug are also inserted into a portal opposite of the sensor eye for use with the RT-Series Ultrasonic Cleaning Module Kit (P/N 56208) in applications requiring automated inline cleaning.

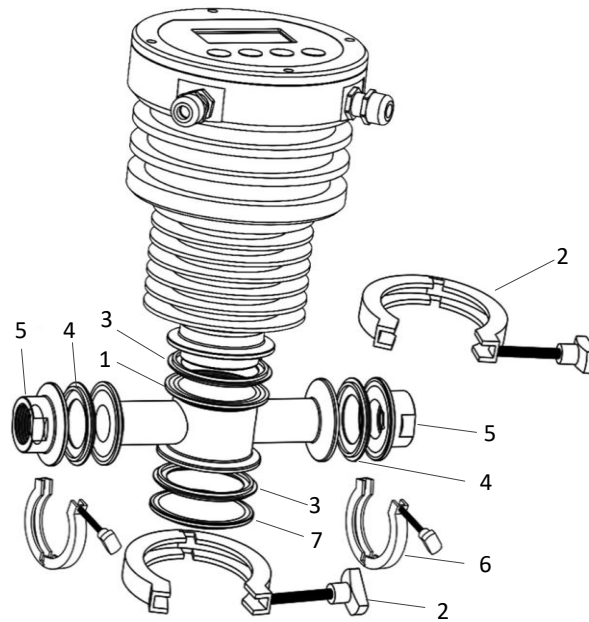

**Figure 3.** Tri-Clamp Flow Cell Assembly (P/N: 56206)

**Table 3.** Tri-Clamp Flow Cell Assembly Components

ID #	Description
1	Flow cell with 2.5-inch Port for Prism RT-200 Sensor Head
2	Sensor Tri-Clamp 2.5-inch
3, 4	Tri-Clamp Flow Cell Gasket Kit (P/N: 56209)
5	3/4-inch NPT Flange
6	Flange Tri-Clamp 2-inch
7	Plug Cap $\phi$ 64mm, Reserved Port for Ultrasonic Cleaning Module

## 4.2 Piping & Flow Parameters

The Prism RT-200 with Tri-Clamp Flow Cell Assembly should be installed per the diagram provided in Figure 4. Be sure to avoid installations illustrated in Figure 5. As outlined in the specification table, operating flow sample pressure should not exceed 142psi (98MPa) and the sample flow rate should remain below 13.5 gpm (9.8 ft/s).

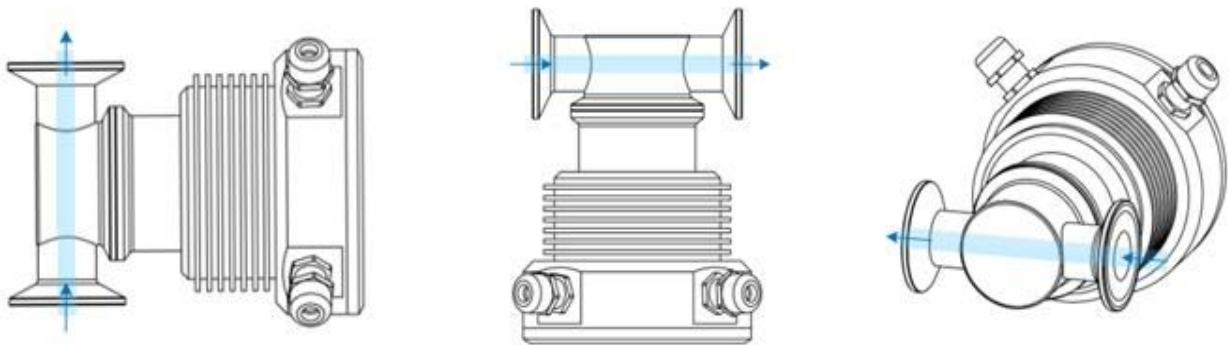

**Figure 4. Correct Installations**

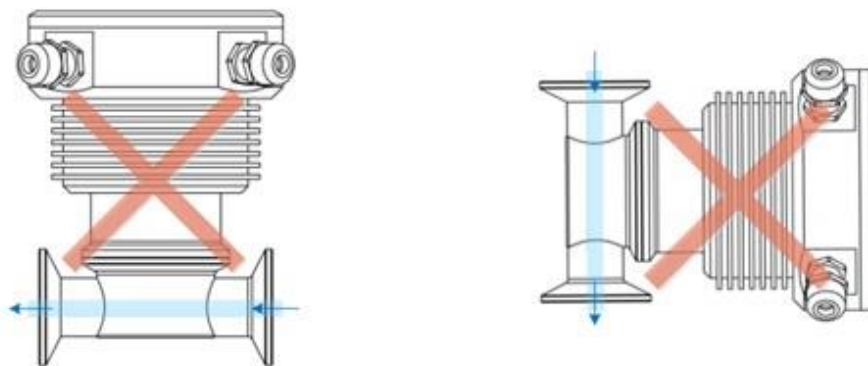

**Figure 5. Incorrect Installations**

### 4.3 RT-200 Wiring

The Prism RT-200 unit offers two (2) cable points of attachment, both terminated with a unique connector (Figure 6). The Prism RT-200 may be powered via a direct 24VDC supply source (via 8-Pin cable provided with the Prism RT-200) or by the provided accessory called Prism RT-series Wall Outlet Power Supply Adapter Kit (P/N 56207). Explanation of each option below:

#### Powered by a Direct 24VDC Power Source via 8-Pin Cable Provided with Prism RT-200

For applications where the Prism RT-200 is connected to and directly powered by 24VDC source (Controller, PLC, DCS etc.), the device should be connected via the 8-Pin Cable and MA-1.5CR Flying Lead Cable. These cables provide power as well as 4-20mA and RS-485 output communication to the connected device. Please refer to Table 4 for wire designations of the 8-pin cables.

#### Powered by a Prism RT-Series Wall Outlet Power Supply Adapter Kit

For applications desiring the Prism RT-200 to be powered by a standard 110VAC wall outlet, Pyxis offers the Prism RT-Series Wall Outlet Power Supply Kit (P/N: 56207). This kit offers a 2-Pin cable and wall outlet adapter for direct power supply from a standard 110VAC wall outlet. **\*NOTE\*** *In the wall outlet powering format, there is no need to terminate the power supply portion of the 8-Pin Cable. This cable may continue to be used in order to pass 4-20mA and RS-485 output signals or for use with the MA-CR Bluetooth adapter for uPyxis® App access.*

**Table 4.** Wire Designations

Wire Color	Designation
Red	24V +
Brown	24V Power ground
Gray*	4–20mA -
White	nD/Brix/Others %, 4–20mA +
Pink	Temperature, 4–20ma +
Blue	RS-485 A
Yellow	RS-485 B
Green	RS-485 Ground

**\*NOTE\*** *The GRAY wire is Internally connected to the power ground. The 4-20mA output from RT-200 is not loop powered and should be landed as a PASSIVE 4-20mA input to the receiving device.*



**Figure 6.** Prism RT-200 with Wall Outlet Supply Adapter Kit (P/N: 56207) and MA-1.5CR Flying Lead Cable (P/N: 50746)

## 5 Instrument Overview

### 5.1 Key Functions



Figure 7. Prism RT-200 Main Display Screen

Table 5. Prism RT-200 Key Functions

Key	Function Description
MODE	Launch setup function associated with the current mode
↑ and ↓	Use arrow keys to select the desired measurement mode (units) from the drop-down list of options.
OK	Click OK for selection confirmation. Be sure to <b>PRESS &amp; HOLD</b> the OK key for 3-SECONDS to set the selected measurement mode as the DEFAULT. This will ensure upon power loss and restart, the RT-200 automatically starts up to the user selected measurement mode on the HOME  display.

## 5.2 Measurement Modes

The Prism RT-200 measures the sample refractive index (nD) and temperature. Use the arrow keys to select the concentration units that are calculated from nD and the temperatures with using the pre-loaded equations for Brix, MPG, MEG, and ALV, etc. The main output of 4-20mA signal value switches with the display concentration selected per the 4-20mA output scales section 9.1 of this manual. **\*NOTE\*** To set the selected display as the DEFAULT display upon power-up after a power-loss, please Press and HOLD the selection confirmation for a period of 3-seconds. This will set the selected display as the default even during power cycles. If not, the unit will always revert back to nD (Refractive Index) upon power-up after a power-loss.



Figure 8. nD



Figure 9. MEG %



Figure 10. MPG %



Figure 11. ALV %



Figure 12. Brix %



Figure 13. Custom %

### 5.3 Sensitivity Setup

A higher sensitivity value set will result in a slower sensor response and the displayed value will show less fluctuation. For applications that require very accurate refractive index measurement, and the refractive index does not undergo any rapid changes in the time scale of minutes, the sensitivity should be set up to the highest value of 30.



Figure 14. - Sensitivity

### 5.4 Cleaning Cycle Setup

RT-200 supports an extended ultrasonic cleaning function using the Ultra-Sonic RT-Series Cleaning Module Kit (P/N 56208). When working in synchronization with the RT-Series Ultrasonic Cleaning Module, the working cleaning cycle is set by RT-200 in increments of every 5, 15 or 30 minutes for a cleaning duration of 5-seconds per cycle. The RT-200 default programmed cleaning time is every 15-minutes. For pricing, technical data and programming of the Ultra-Sonic Cleaning Module Kit, please contact [order@pyxis-lab.com](mailto:order@pyxis-lab.com)



Figure 15. – Programming the Clean Cycle Frequency

### 5.5 Reset Parameters

This mode will erase the user's calibration and setting information, restore the factory calibration and setting information, including air calibration, brix/liquid concentration offset calibration, sensitivity, etc.



Figure 16.



Figure 17.

## 6 Calibration

Calibration for refractive index is not required for the RT-200 use. The Prism RT-200 can however be calibrated in air to correct possible misalignment and aging of the optic components. An offset calibration for each concentration unit (but not for refractive index) is provided to allow the user to adjust the RT-200 using a liquid sample with known concentration value in that specific liquid unit of measure.

### 6.1 Air Calibration of Refractive Index

1. Clean the Prism RT-200 sapphire lens with soft tissue.
2. If any tenacious deposits are present on the sensor lens, you may pre-soak the sensor lens in Pyxis Probe Cleaning Solution (P/N: SER-01) for 10–15 minutes, then rinse with clean water and wipe with soft tissue prior to proceeding to air calibration of refractive index.

**\*NOTE\*** Please refer to the Section 10.1 **Methods to Cleaning the Prism RT-200** for details.

3. After properly cleaning the sensor lens, remove any residual liquid from the sapphire lens.
4. Shield the lens from the ambient light. This is usually done by inserting the RT-200 sensor eye into an EMPTY beaker then shielding the sensor and beaker from light with a dark towel.
5. Press the **MODE** key on the face of the unit to launch the air calibration interface (Figure 20).
6. Press and hold the **OK** key on the face of the unit for 3 seconds to start the air calibration process (Figure 21).
7. Once the calibration is complete, press the **MODE** key to return to measurement mode (Figure 22).



Figure 18.



Figure 19.

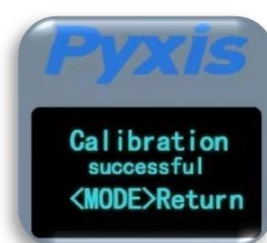

Figure 20.

## 6.2 Brix and Other Liquid Concentration Offset Calibration

The refractive index value **does not require calibration** as stated in Section 6.1. The refractive index and temperature values are internally converted to the desired liquid concentration unit selected through the display of the sensor interface. This displayed liquid concentration unit value may be calibrated (adjusted) to a known solution if desired as an enhancement to the internal conversion calculations within the RT-200 firmware. To do this:

1. Place the Prism RT-200 in the calibration liquid of a known concentration making sure the sensor is covered from ambient light. (ie. Sample liquid and RT-200 in a beaker covered with dark towel)
2. Use the **ARROW** keys on the sensor display to select the corresponding concentration unit of your sample.
3. Press the **MODE** key on the sensor display to launch the offset calibration interface for the specific concentration unit selected.
4. Proceed through the screen prompt steps to calibrate unit to the known concentration of liquid standard.



Figure 21.

## 7 Setup and Configuration with uPyxis® 2.0 Mobile App

### 7.1 Download uPyxis® 2.0 Mobile App

Download uPyxis® Mobile App from [Apple App Store](#) or [Google Play](#).



Figure 22. uPyxis® 2.0 Mobile App installation

### 7.2 Connecting to uPyxis® 2.0 Mobile App via Built-in Bluetooth

The RT-200 has added built-in Bluetooth 5.0, which can directly connect to a phone or PC through Bluetooth. Figure 23 shows that the Prism RT-200 is powered by a controller through the 8-Pin cable provided with the Prism RT-200, however, the Bluetooth function will also work if the RT-200 is powered via the Wall Outlet Power Supply Adapter Kit.

**\*NOTE\*** uPyxis® 2.0 Mobile is for mobile devices (ie. smart phones, smart pads) and communicates directly with RT-200 via Bluetooth 5.0 connectivity. This wireless connectivity may also be used with uPyxis® 2.0 Desktop (ie. Laptops) and requires the MA-NEB (USB Bluetooth adapter) to be installed in the PC for wireless access to RT-200. For PC's operating on WINDOWS 10 and newer, do NOT need to use the MA-NEB.

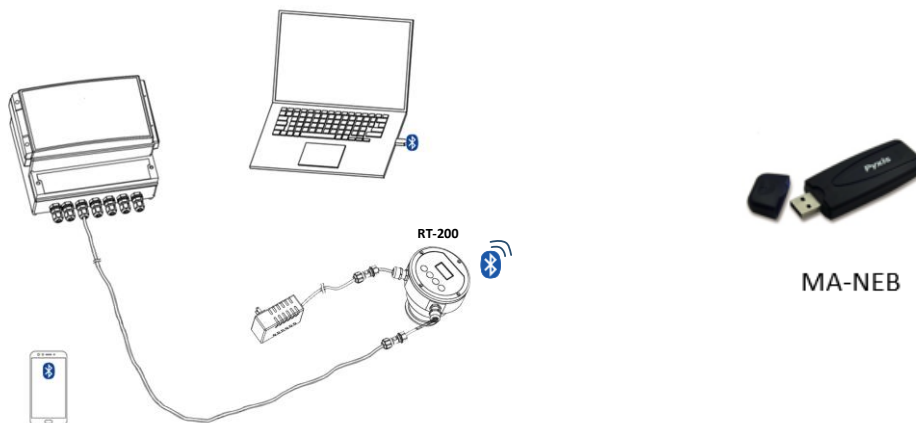

Figure 23. 24VDC Powered via Controller through 8-Pin Cable and MA-NEB Bluetooth Adapter

1. Power on the RT-200.
2. Open the **uPyxis®2.0** Mobile App.
3. In the **uPyxis®2.0** Mobile App, swipe down with finger on the main screen to refresh the list of available Pyxis devices. **\*NOTE\*** *this may take multiple finger swipes for Bluetooth to connect to the device.*
4. If the connection is successful, the Prism RT-200 and its Serial Number (S/N) will be displayed (Figure 26).
5. Press on the **Prism RT-200 sensor image**.



Figure 24. – Discovered RT-200 on uPyxis 2.0 Mobile APP

### 7.3 Trend Chart

When connected, the **uPyxis® 2.0** Mobile App will default to the **Trend Chart** screen. From the **Trend Chart** screen, the user can select substances for curve display.

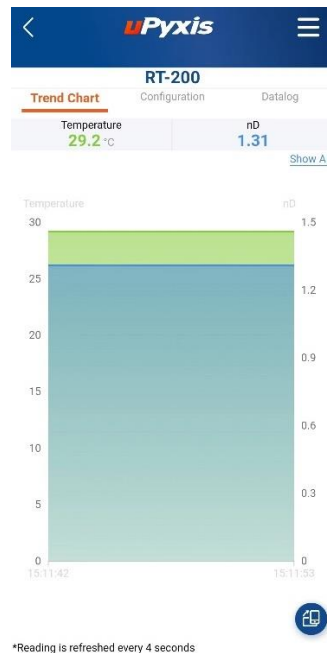

Figure 25. – Trend Chart uPyxis 2.0 Mobile APP.

## 7.4 Device Configuration

From the **Configuration** screen. You can name the Device or Product as well as set the Modbus address.



**Figure 26.** – Device Info Screen Interface

The Configuration Screen performs the various forms of calibrations as discussed in this manual (see Sections 6.1 & 6.2) by pressing on **Air Calibration** and **Bias Calibration (Offset Calibration)**. The calibration objective is determined by the drop-down box selected. Follow the screen instructions for each calibration step. The user may also perform a factory reset of all calibration values saved in the device by pressing **Factory parameter Restore**.

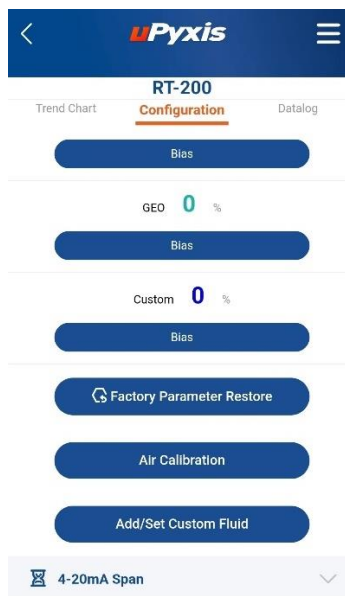

**Figure 27.** – Configuration Screen Interface uPyxis Mobile APP.

**Setting 4-20mA Range.** The 4-20mA output range for any concentration scale may be modified by the user, if the default range is not suitable for you. This feature enables the user to adjust the 4-20mA output values of the RT-200 for the concentration curve as desired. **\*NOTE\*** 20mA value adjustment must be LESS than the highest default 20mA output value of the concentration selected. (ie. for BRIX concentration, the 20mA value may be set to 100% or lower). Please refer to Section 9.1 for default 4-20mA output scales of the RT-200.



**Figure 28.** – Setting 4-20mA Range

## 7.5 Add/Set Custom Fluid

In order to adapt to more application scenarios, users can create and add new customized fluids through the uPyxis APP and display them on the OLED screen. This method will establish a formula between the new fluid and Brix%, and the accuracy can reach  $\pm 0.2\%$ . Modification of the Custom Fluid Name and Coefficient are also supported via uPyxis.

### STEP 1 - Name the Custom (New) Fluid

The name should not exceed 7 characters in length. **\*NOTE\*** Only alphanumeric and “\_” may be used.

### STEP 2 - Entering at Least 5-sets of Custom Product Concentration Data

The user should then enter at least 5-sets of the Custom (New) Fluid Concentration (%) and to the corresponding Brix (%) concentration already populated in the table. The uPyxis App will calculate and establish the coefficient formula between the Custom (New) Fluid Concentration (%) and Brix (%). **\*NOTE\*** If your data correlation coefficient  $R^2$  is less than 0.8, the uPyxis APP will **NOT** permit you to proceed to the next step and users must check their concentration data for accuracy.

### STEP 3 - Confirm

Apply this custom fluid and display it on the OLED screen.

### STEP 4 - Set Custom (New) Fluid 4-20mA Range & Sensor Output Scale

According to the concentration range of the Custom (New) Fluid, refer to Section 7.4 setting 4-20mA range. Enter the appropriate concentration (%) of 4mA, and concentration (%) of 20mA to program the 4-20mA output scale from the sensor. **\*NOTE\*** It is important to remember this output scale for programming the signal receiving device accurately (ie. Controller, PLC or Network)

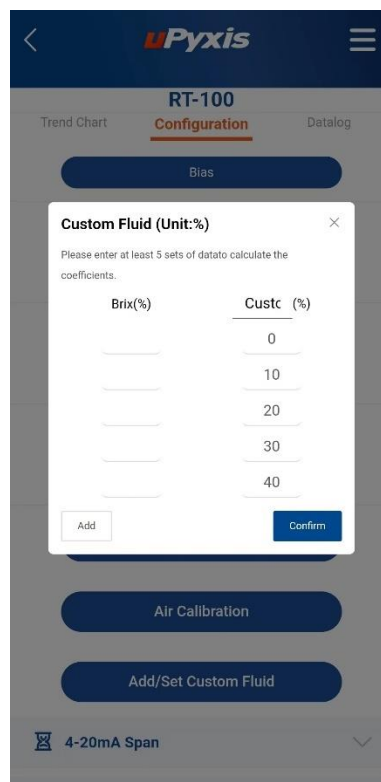

Figure 29.

### 7.6 Diagnosis Screen

From the **Diagnosis** screen, the user can check the diagnosis condition. This feature may be used for technical support when communicating with [service@pyxis-lab.com](mailto:service@pyxis-lab.com).

**Get spectrum data**, if necessary, spectral data can also be obtained to assist in diagnosing sensor issues.



Figure 30. – Diagnosis Screen Interface

### 7.7 Data log Screen

The user can choose the time period of data export, including: hour, day, week, month, and all data stored. After select, wait for the progress bar to load.

**\*NOTE\*** *The Prism RT-200 is programmed to store data at a frequency of once per minute with a maximum of 56 days storage capacity.*

The **Data Log** screen’s functions are described in table below:

**Table 6. – Data Log Screen Functions**

Function	Description
Remove all Data records	The removal of unnecessary historical data is a relatively slow process. Do not power off during the process.
Export <a href="#">hour/day/week/month/all</a> History Data records	The historical data is exported and saved in CSV format. The storage contents include refractive index nD, temperature °C, Brix, MEG, PEG and others.

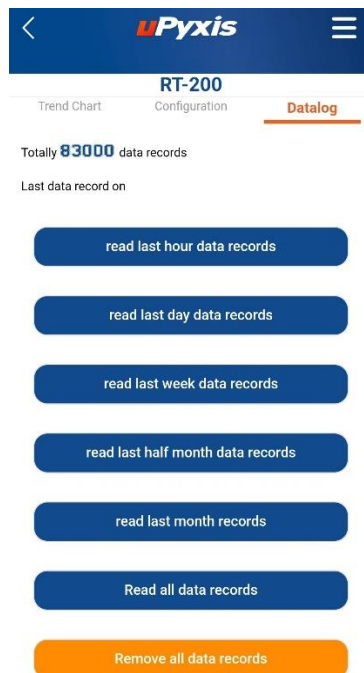

**Figure 31. – Data Log**

## 8 Setup and Calibration with uPyxis® Desktop App

### 8.1 Install uPyxis® Desktop App

Download the latest version of **uPyxis®** Desktop software package from: <https://upyxis.pyxis-lab.com.cn/release/pc/uPyxis.Setup-latest.zip>

This setup package will download and install the Microsoft.Net Framework 4.5 (if not previously installed on the PC), the USB driver for the USB-Bluetooth Adapter (MA-NEB), the USB-485 Adapter (MA-485), and the main **uPyxis®** Desktop application. Double click the **uPyxis.Setup.exe** file to install.

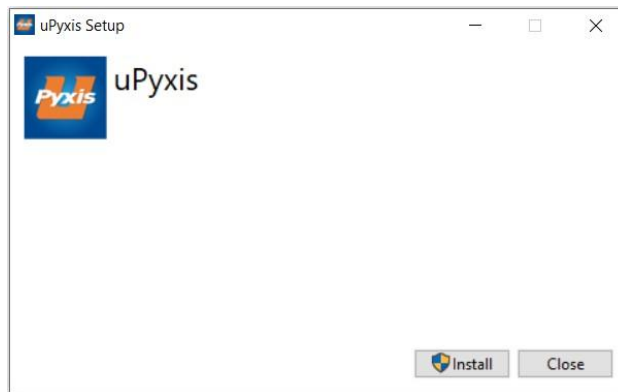

*Figure 32. uPyxis® Desktop App installation*

Click **Install** to start the installation process. Follow the screen instructions to complete the USB driver and **uPyxis®** installation.

## 8.2 Connecting to uPyxis® Desktop App via USB-C Cable

For those desiring not to use wireless connection to uPyxis Desktop, the MA-CR Bluetooth adapter (P/N: MA-CR) can be purchased as an optional accessory to connect an RT-200 sensor to a laptop or a desktop computer with a USB-C cable and the **uPyxis®** Desktop App. In this format, the power should be sourced from the laptop via the USB-C cable connected to the MA-CR and Laptop USB-C port.

- 1) Download and install uPyxis Desktop APP from <https://upyxis.pyxis-lab.com.cn/release/pc/uPyxis.Setup-latest.zip>
- 2) Connect a USB Type-C cable to the port at the bottom of the MA-CR and to the USB port of the laptop or computer. This will provide power the MA-WB from the laptop/computer. Connect the MA-CR to the RT-200 sensor. The MA-CR Bluetooth adapter will boost the 5V of the regular USB to 24V to power the sensor for use with uPyxis Desktop App.



MA-CR Bluetooth Adapter – Bottom USB-C

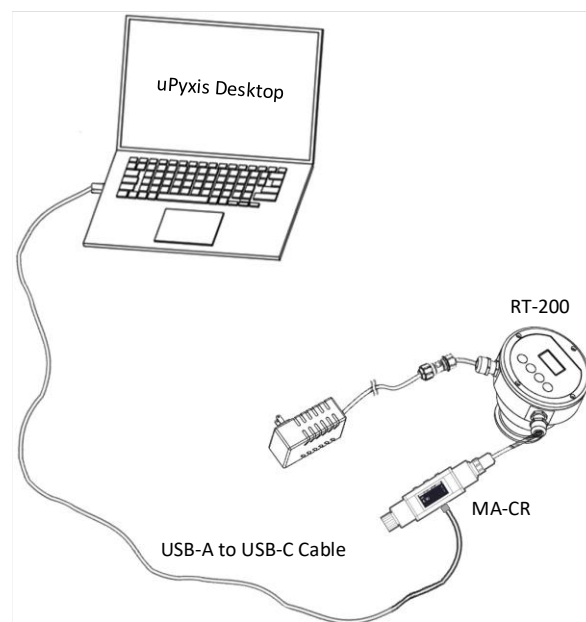
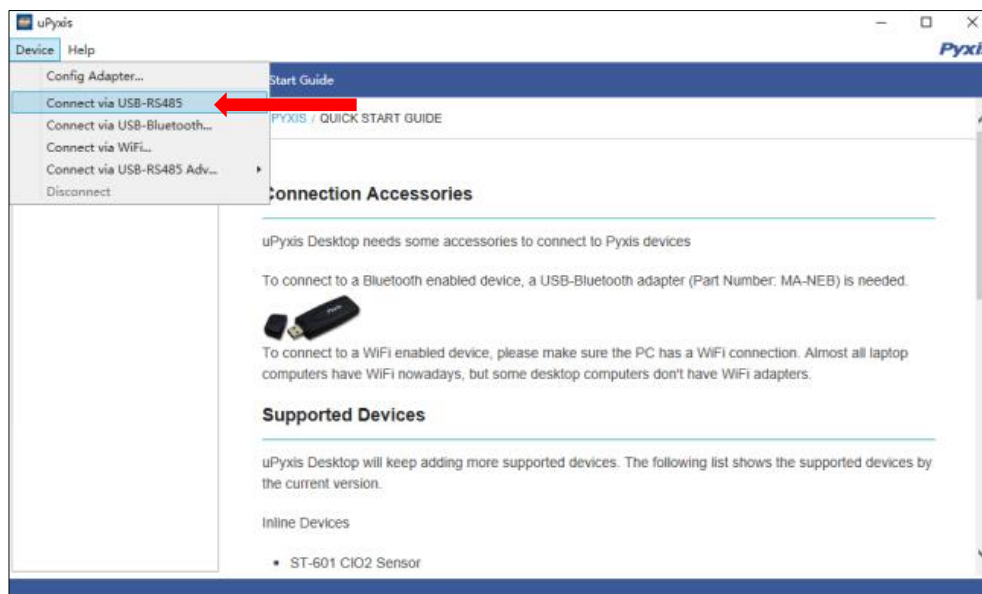

**Figure 33.** – MA-CR Adapter Connected via USB-C to Laptop for uPyxis Desktop Use

- 3) Set the MA-CR to operate in USB Mode by following the steps below.
  - a. Once the MA-CR screen is powered Press ◀ or ▶ until you arrive at (USB to RS485) screen.
  - b. Press the **OK** Button.
  - c. Follow Prompts below to Enable USB feature. Once enabled, you may connect to uPyxis.



- 4) Open the desktop uPyxis APP.
- 5) Click Device to launch the connection option menu.
- 6) Select Connect via USB-RS485 (Figure 36).
- 7) Select the Comm Port to make a connection. Normally only one Comm port is identified by uPyxis. If more than one Comm port listed in the selection dropdown, you may try to select each one to see if a connection can be made. Alternatively, you may use the Windows Device Manager to identify the Comm Port that the Pyxis USB adapter is using.



**Figure 34.** - Connect to RT-200 via USB-RS485 option

### 8.3 Information Screen

Once connected to the device, a picture of the device will appear on the top left corner of the window and the **uPyxis®** Desktop App will default to the **Information** screen. On the **Information** screen you can set the information description for **Device Name**, **Product Name**, and **Modbus Address**, then click **Apply Settings** to save.

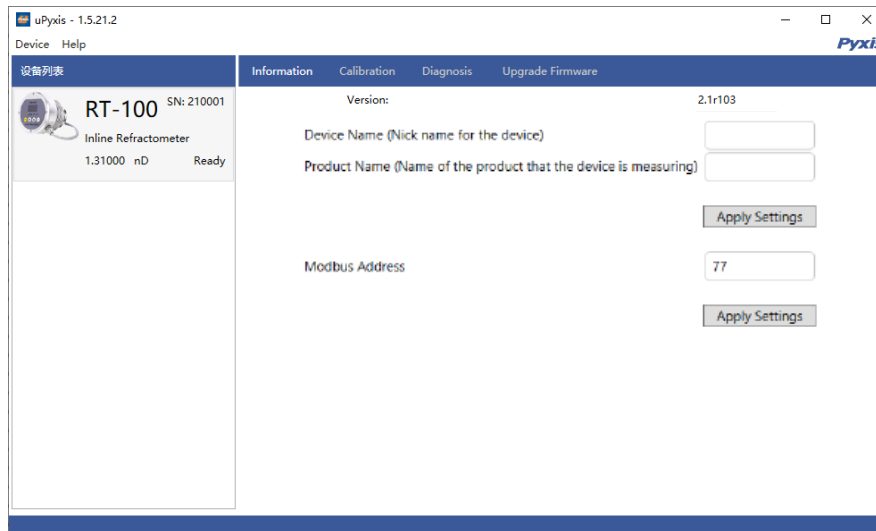

**Figure 35.** – Information Screen uPyxis Desktop

## 8.4 Calibration Screen

To calibrate the device, click on **Calibration**. From the **Calibration** screen, the user can perform the various forms of calibrations as discussed in this manual (see Sections 6.1 and 6.2) by pressing on **Air Calibration and Bias Calibration (Offset Calibration)**. The calibration objective is determined by the drop-down box selected. On the **Calibration** screen there are seven calibration options based on the including **AIR CALIBRATION, BRIX, MEG, MPG, ALV, ALV+ and GEO**. Follow the screen instructions for each calibration step.

The user may also perform a factory reset of all calibration values saved in the device by pressing **Restore Factory** and entering 'upyxis' into the prompt.

**Setting 4-20mA Range** The 4-20mA output range for any concentration scale may be modified by the user, if the default range is not suitable for you. This feature enables the user to adjust the 4-20mA output values of the RT-200 for the concentration curve as desired. **\*NOTE\*** 20mA value adjustment must be LESS than the highest default 20mA output value of the concentration selected. (ie. for BRIX concentration, the 20mA value may be set to 100% or lower). Please refer to Section 9.1 for default 4-20mA output scales of the RT-200.

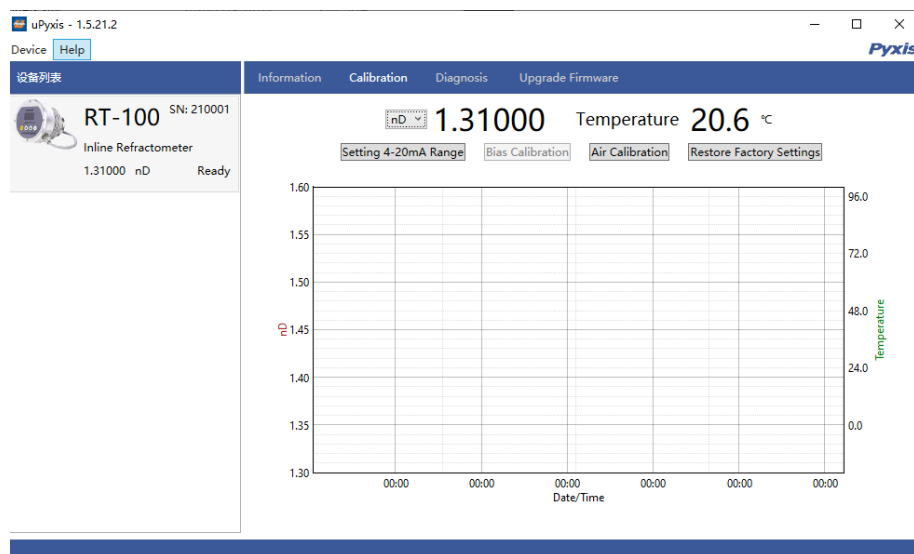

Figure 36.

### 8.5 Add/Modify Custom Fluid

In order to adapt to more application scenarios, users can add new fluids through uPyxis and display them on the OLED screen. This method will establish a formula between the new fluid and Brix%, and the accuracy can reach  $\pm 0.2\%$ . Modification of the Custom Fluid Name and Coefficient are also supported via uPyxis.

#### STEP 1 - Name the Custom (New) Fluid

The name should not exceed 7 characters in length. **\*NOTE\*** Only alphanumeric and “\_” may be used.

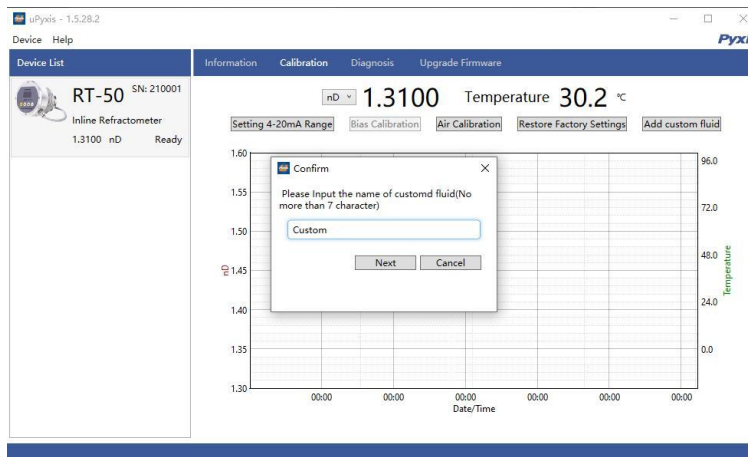

Figure 37.

#### STEP 2 - Entering at Least 5-sets of Custom Product Concentration Data

The user should then enter at least 5-sets of the Custom (New) Fluid Concentration (%) and to the corresponding Brix (%) concentration already populated in the table. The uPyxis App will calculate and establish the coefficient formula between the Custom (New) Fluid Concentration (%) and Brix (%). **\*NOTE\*** If your data correlation coefficient  $R^2$  is less than 0.8, the uPyxis APP will **NOT** permit you to proceed to the next step and users must check their concentration data for accuracy.

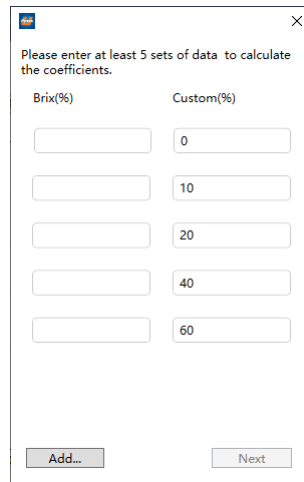
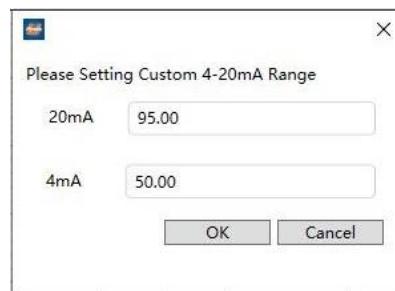

Figure 38.

**STEP 3 - Set Custom (New) Fluid 4-20mA Range & Sensor Output Scale**

According to the concentration range of the Custom (New) Fluid, enter the appropriate concentration (%) of 4mA, and concentration (%) of 20mA to program the 4-20mA output scale from the sensor. **\*NOTE\*** It is important to remember this output scale for programming the signal receiving device accurately (ie. Controller, PLC or Network)



Please Setting Custom 4-20mA Range

20mA 95.00

4mA 50.00

OK Cancel

**Figure 39.**

**STEP 4 - Apply the Custom (New) Fluid Settings and Display**

Please confirm whether to apply this custom fluid and display it on the OLED screen. Once OK is pressed, the uPyxis APP will apply this customized firmware to the RT-50 process control board and the unit is now set to display your custom fluid.



Do you agree to display Custom% on OLED?

Yes No

**Figure 40.**

### 8.6 Diagnosis Screen

From the **Diagnosis** screen, the user can check the diagnosis condition. This feature may be used for technical support when communicating with [service@pyxis-lab.com](mailto:service@pyxis-lab.com).

The user can choose the time period of data export, including: hour, day, week, half month, and all data stored. After selecting the time, press **Export History Data** and wait for the progress bar to load.

**\*NOTE\*** The Prism RT-200 is programmed to store data at a frequency of once per minute with a maximum of 56 days storage capacity.

The **Diagnosis** screen’s functions are described in table below:

Table 7.

Function	Description
Wipe History Data	The removal of unnecessary historical data is a relatively slow process. Do not power off during the process.
Export Spectrum	Derive the original spectrum.
Export History Data	The historical data is exported and saved in CSV format. The storage contents include refractive index nD, temperature °C, Brix, EG, and other.
Save & Share	Save the data and send it to other software.
Hour (Dropdown)	Select the length of time to export data. The latest hour is exported by default. Users may select Day, Week, and Half-Month. Data can be exported for up to 56 days.

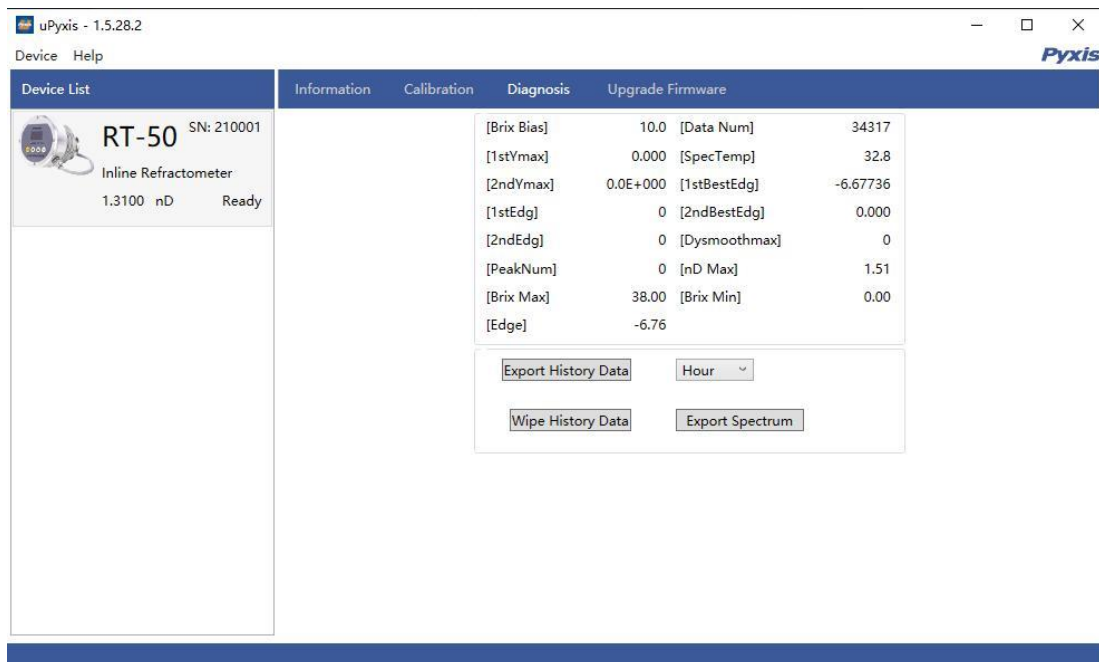

Figure 41.

## 8.7 Upgrade Firmware

RT-200 must be used in usb connection mode. Select the “\*.bin” file for firmware update, if you need to fix some issues with the firmware of your device.

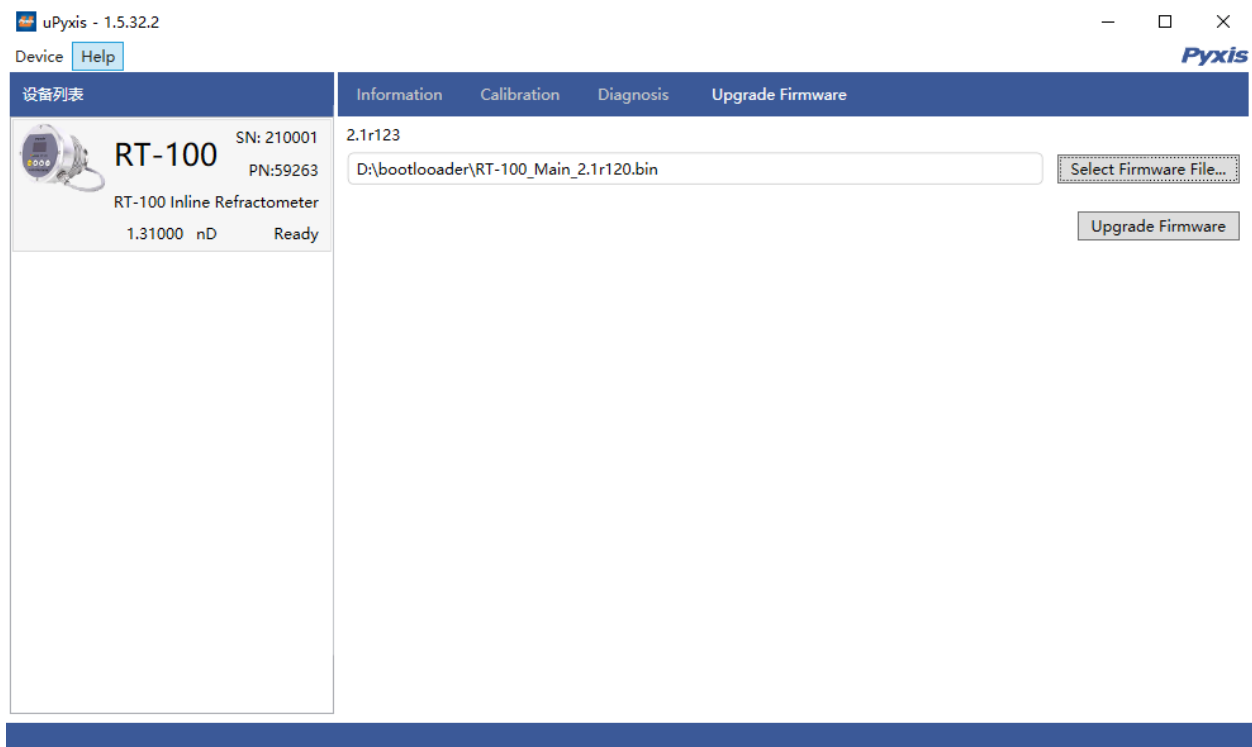

Figure 42.

## 9 4-20mA Outputs

### 9.1 4–20mA Output Setup

The 4 ~ 20mA range can be modified by uPyxis if the default range is not suitable (refer to Calibration Sections 7.3 and 8.4 of this manual). The 4–20mA default output of the Prism RT-200 sensor is scaled as outlined below.

*Table 8.*

Measurement Mode	4 mA Output Value	20 mA Output Value
Refractive Index (nD)	1.3000	1.5100
Brix (% or Bx)	0%	100%
Mono Ethylene Glycol (%MEG)	0%	100%
Mono Propylene Glycol (%MPG)	0%	100%
Advanced Low Viscosity Fluid (%ALV)	0%	100%
Advanced Low Viscosity Plus Fluid (%ALV+)	0%	100%
Custom Fluid (%)	0%	100%
Temperature	-20 °C	150 °C

### 9.2 Communication using Modbus RTU

The Prism RT-200 sensor is configured as a Modbus slave device. In addition to the nD, %Bx, %MEG, %MPG, %ALV, %ALV PLUS, % Custom and temperature values, many operational parameters, including warning and error messages, are available via a Modbus RTU connection. Contact Pyxis Lab Customer Service ([service@pyxis-lab.com](mailto:service@pyxis-lab.com)) for more information.

### 9.3 Communication with Bluetooth

The RT-200 has added built-in Bluetooth, which facilitates Bluetooth connection for data diagnosis in harsh environments such as high temperatures. The Bluetooth function remains on as the device is powered on. The status of Bluetooth is displayed on the screen.



*Figure 43. Bluetooth on*



*Figure 44. Bluetooth connected*

## 10 Sensor Maintenance and Precaution

### 10.1 Methods to Cleaning the Prism RT-200

For most RT-200 sensor cleanings, the sapphire lens should be rinsed with clean or DI water than wiped clean with a soft tissue. If tenacious inorganic deposits are present on the sapphire lens, soak the lower half of the Prism RT-200 sensor in 100 mL of Pyxis inline sensor cleaning solution (SER-01) for 15-minutes. If the surface is not entirely clean, continue to soak the sensor for an additional time until clean. Lightly wipe the sensor lens with a soft tissue. Rinse sensor eye with clean or DI water. Pyxis Lab Inline Sensor Cleaning Solution can be purchased at our online E-Store/Catalog at <https://pyxis-lab.com/product/probe-cleaning-kit/>



*Figure 45. Inline Probe Cleaning Solution Kit (P/N: SER-01)*

## 11 Contact Us

### Pyxis Lab, Inc

21242 Spell Circle

Tomball TX 77375 USA

[www.pyxis-lab.com](http://www.pyxis-lab.com)

Phone: +1 (866) 203-8397

Email: [service@pyxis-lab.com](mailto:service@pyxis-lab.com)