

MA-ETH

(RS485 to Ethernet Adapter)

Operation Manual

For use on UC-50 Display of the IK-765 Series Panels



January 5, 2023
Rev. 1.1

Pyxis Lab, Inc.
1729 Majestic Dr. Suite 5
Lafayette, CO 80026 USA
www.pyxis-lab.com

Table of Contents

1. Introduce	3
1.1 MA-ETH Interface.....	3
1.2 Specifications.....	3
1.3 Unpacking the MA-ETH	4
1.4 Standard Accessories.....	4
2. Dimension	4
3. Electrical Connection & Installation	4
3.1 MA-ETH Wiring	4
3.2 UC-50 Terminal Board Wiring Diagram	5
3.2.1 Installation Method #1.....	5
3.2.2 Installation Method #2.....	7
4. MA-ETH Operation	9
4.1 Key Function.....	9
4.2 Main Screen	9
4.3 Ethernet Settings.....	9
4.3.1 Select the Method for Obtaining IP addresses	9
4.3.2 IP Configuration Options.....	10
4.4 Serial Port.....	11
4.5 Rotate Screen	11
4.6 Device Information.....	11
5. Communication using Modbus TCP	12
6. Contact Us	12

Warranty Information

Confidentiality

The information contained in this manual may be confidential and proprietary and is the property of Pyxis Lab, Inc. Information disclosed herein shall not be used to manufacture, construct, or otherwise reproduce the goods described. Information disclosed herein shall not be disclosed to others or made public in any manner without the express written consent of Pyxis Lab, Inc.

Standard Limited Warranty

Pyxis Lab warrants its products for defects in materials and workmanship. Pyxis Lab will, at its option, repair or replace instrument components that prove to be defective with new or remanufactured components (i.e., equivalent to new). The warranty set forth is exclusive and no other warranty, whether written or oral, is expressed or implied.

Warranty Term

The Pyxis warranty term for the ST-765SS Series sensor body is thirteen (13) months from original shipment from Pyxis. The Pyxis warranty term for the EH-765 (electrode reference head) installed on the ST-765SS Series sensor body is six (6) months from original shipment from Pyxis. In no event shall the standard limited warranty coverage extend beyond this timeline from original shipment date.

Warranty Service

Damaged or dysfunctional instruments may be returned to Pyxis for repair or replacement. In some instances, replacement instruments may be available for short duration loan or lease.

Pyxis warrants that any labor services provided shall conform to the reasonable standards of technical competency and performance effective at the time of delivery. All service interventions are to be reviewed and authorized as correct and complete at the completion of the service by a customer representative, or designate. Pyxis warrants these services for 30 days after the authorization and will correct any qualifying deficiency in labor provided that the labor service deficiency is exactly related to the originating event. No other remedy, other than the provision of labor services, may be applicable.

Repair components (parts and materials), but not consumables, provided during a repair, or purchased individually, are warranted for 90 days ex-works for materials and workmanship. In no event will the incorporation of a warranted repair component into an instrument extend the whole instrument's warranty beyond its original term.

Warranty Shipping

A Repair Material Authorization (RMA) Number must be obtained from Pyxis Technical Support before any product can be returned to the factory. Pyxis will pay freight charges to ship replacement or repaired products to the customer. The customer shall pay freight charges for returning products to Pyxis. Any product returned to the factory without an RA number will be returned to the customer. To receive an RMA you can generate a request on our website at [Request Return or Repair - Pyxis Lab, Inc. \(pyxis-lab.com\)](https://www.pyxis-lab.com/Request-Return-or-Repair)

Pyxis Technical Support

Contact Pyxis Technical Support at +1 (866) 203-8397 or by emailing service@pyxis-lab.com

1. Introduce

The MA-ETH (P/N 21612) is an adapter designed for use as an attachment to UC-50 display/data logging terminal. Provided with a 0.96" display to show communication status, the MA-ETH can convert RS-485 to Ethernet supporting MODBUS TCP and MODBUS RTU protocol conversion. The MA-ETH also supports DHCP automatic fetching, manual changing of the IP address and communication Porter Rate and parity bit modification.



1.1 MA-ETH Interface



Figure 1. MA-ETH Interface

1.2 Specifications

Item	MA-ETH
P/N	21612
Power Supply	22 – 26V DC
MA-ETH Display	0.96" Color 128 x 64 Resolution
Material	ABS
Storage Temperature	-7 °C – 60 °C (20 – 140 °F)
Operating Temperature	4 °C – 50 °C (40 – 122 °F)
Input Signal	RS-485
Output Signal	Ethernet
Dimension (L x W x H)	126.2*32*32mm
Cables Included	Flying Lead Cable w/male7-Pin Adapter – 0.3m (0.9ft) 8-Pin to 7-Pin Conversion Adapter – 0.2m (0.6ft)
Weight	530 g (1.16lbs)
Regulation	CE Marked / RoHS

**NOTE* Specifications are subject to change without notice.*

1.3 Unpacking the MA-ETH

Remove the instrument and accessories from the shipping container and inspect each item for any damage that may have occurred during shipping. Verify that all items listed on the packing slip are included. If any items are missing or damaged, please contact Pyxis Customer Service at service@pyxis-lab.com

1.4 Standard Accessories

- One MA-ETH (P/N: 21612)
 - Includes One Flying Lead Cable with Male 7-Pin Adapter - 0.3m/ 0.9 feet
 - Includes One 8-Pin to 7-Pin Conversion Adapter - 0.2 m / 0.6 feet

2. Dimension

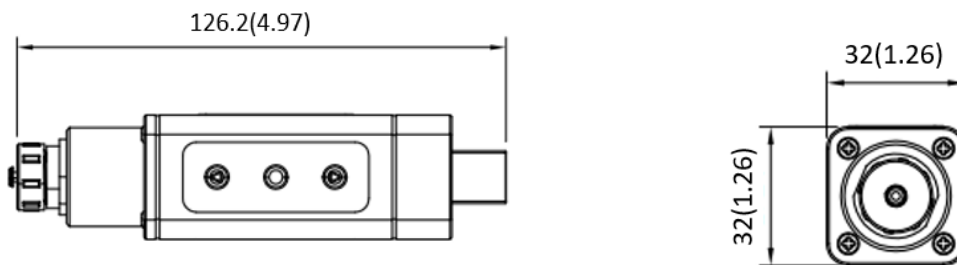

Figure 2. Dimensions of the MA-ETH mm(inch)

3. Electrical Connection & Installation

3.1 MA-ETH Wiring

Follow the wiring table below to connect the MA-ETH flying lead cable to the UC-50.

Wire Color	Designation
Red	24 V +
Brown	Power Ground
Blue	485 A
Yellow	485 B

3.2 UC-50 Terminal board wiring diagram

The UC-50 is a universal display for all Pyxis sensors. Based on different sensor and installation formats, the terminals of the UC-50 may be wired differently. This manual offers two (2) potential methods of wiring the MA-ETH adapter to the UC-50 and represents the ST-765SS Series Oxidizer + pH sensor provided on the Pyxis OxiPanel IK-765 Series analyzers.

⚠ WARNING Any wiring of the UC-50 should only take place while the device is de-energized.

3.2.1 Installation Method #1

For UC-50 display units that are integrated into a Pyxis OxiPanel IK-765 Series analyzers, users should not need to disassemble the UC-50 housing for connection of the MA-ETH adapter. The user can connect MA-ETH to the prewired 8-Pin output cable already connected to the UC-50 by installing the 8-Pin to-7-Pin Conversion Adapter provided with the MA-ETH package. Once connected, the user can power the MA-ETH by activating the 24-VDC relay in the UC-50 as outlined in the next section of this document.

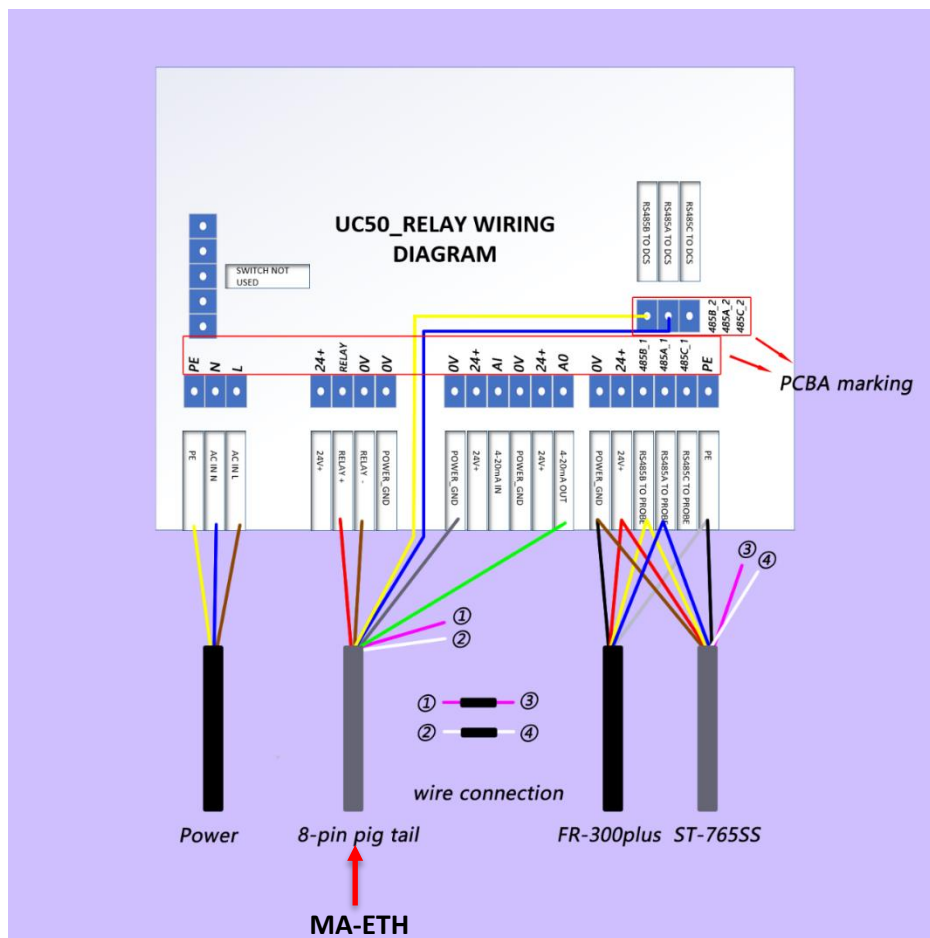

Figure 3. Example UC-50 Wiring Diagram #1

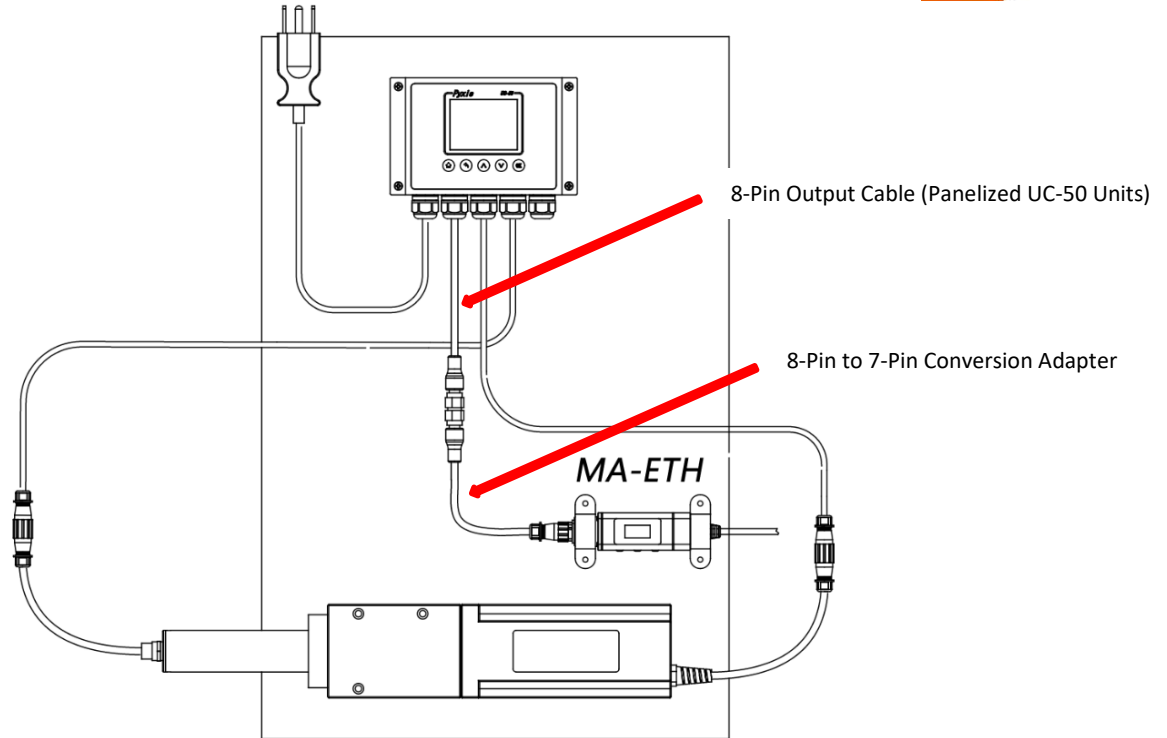

Figure 4. Installation Diagram Method #1

Turning ON the UC-50 Relay Output

1. From the main screen, scroll down the menu list and select **Relay Configuration**.
2. Press the **OK** key to highlight the mode field (highlighted field is black), then press **OK** to enter edit mode (edit mode is blue), press ▲ or ▼ to select manual mode (Figure 5).
3. Move the cursor to the **Turn On** button and click **OK** to enable 24V output of the UC-50 relay terminal to power the MA-ETH (Figure 6).

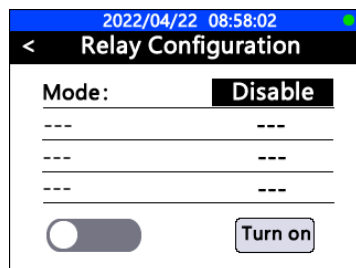

Figure 5. Relay Configuration

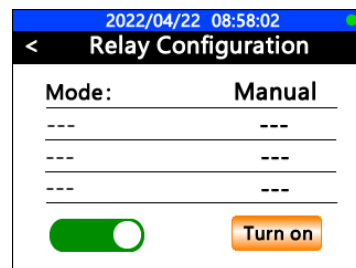

Figure 6. Turn on relay output

3.2.2 Installation Method #2

For UC-50 units that do not offer a prewired 8-in output cable, users will need to open UC-50 housing and wire the MA-ETH manually to the UC-50 terminal board. To do this, users should connect wire the Flying Lead Cable male/ 7-Pin Adapter that is provided with each MA-ETH package as outlined in the diagram below.

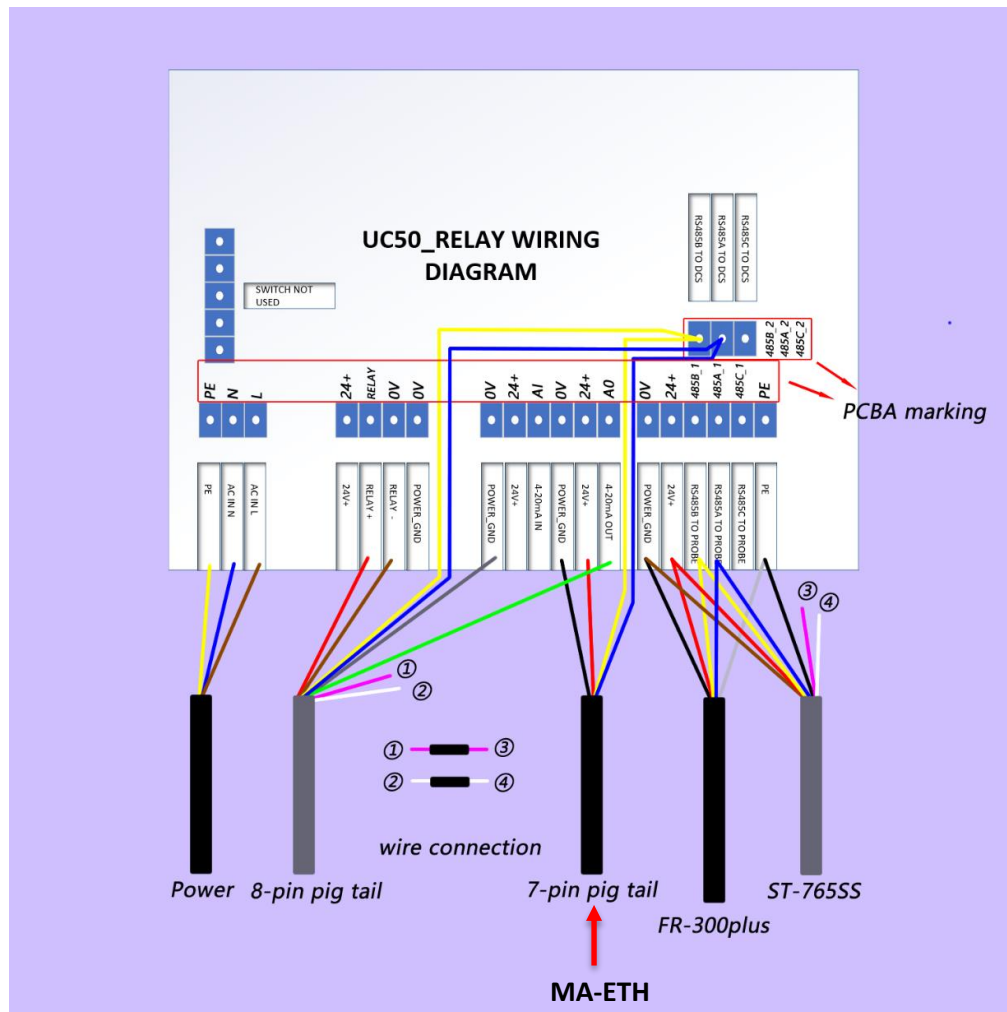

Figure 7. Example UC-50 Wiring Diagram #2

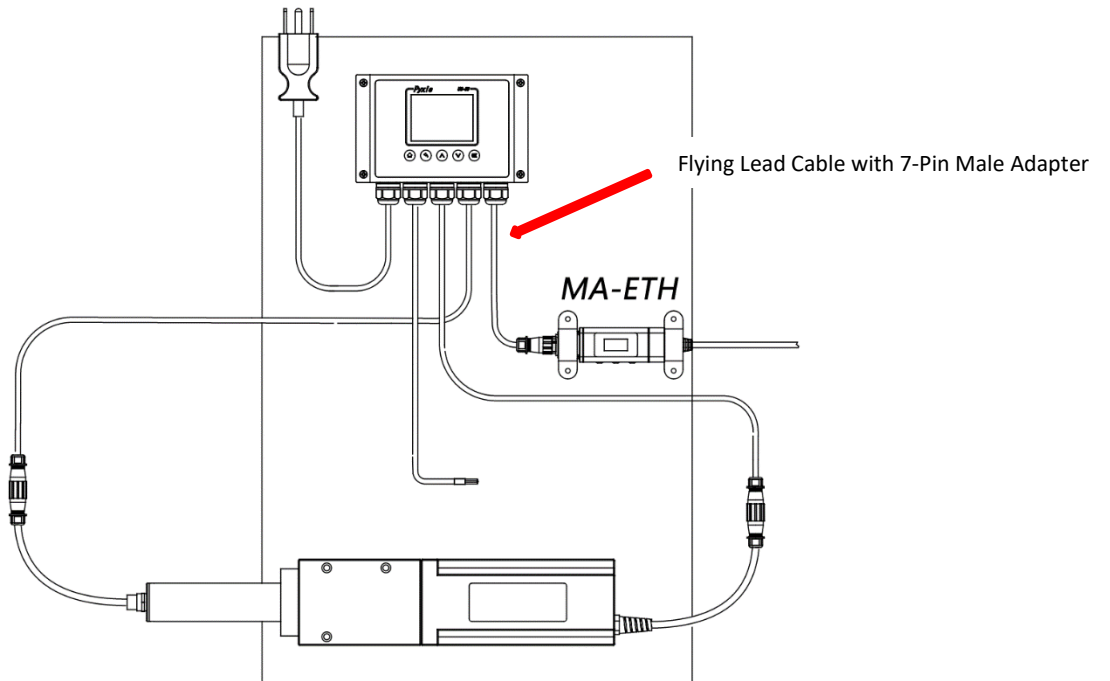

Figure 8. Installation Diagram Method #2

4. MA-ETH Operation

4.1 Key Function

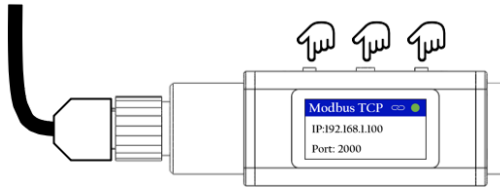

Figure 9. Key Function

● **Enter Key**

- Main Screen → Setting Menu
- Confirm settings

◀ ▶ **Left / Right Key**

- Select Different Parameters
- Change Page

4.2 Main Screen

When first powered-on, the MA-ETH is set to obtain static IP by default.

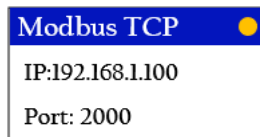

Figure 10. Main page

Main Page Symbol Description

Symbol	Meaning
●	No network cable is connected.
●	Network cable is connected.
🔗	The IP address was accessed successfully.

4.3 Ethernet Settings

4.3.1 Select the Method for Obtaining IP Addresses

The IP address is the identity representation of the module in the LAN, which is unique in the LAN and therefore cannot be repeated with other devices in the same LAN. The IP address of MA-ETH can be obtained two ways: static IP (fix IP) and DHCP (dynamic IP). Press ◀ or ▶ in the setting menu to select **[Ethernet]** to enter the **Protocol** page.



Figure 11.

4.3.2 IP Configuration Options

- **Static IP (Fix IP)**

The static IP needs to be set manually by the user, and the IP and port number should be written at the same time during the setting process. The static IP is suitable for the scenario that requires a one-to-one correspondence between IP and equipment.



Figure 10.

- **DHCP (Dynamic IP)**

The main function of DHCP is to obtain the IP address from the gateway host dynamically, to avoid the tedious step of setting the IP address. If you choose the **Dynamic IP** option, you only need to enter port number in the **Configuration** page.



Figure 11.

After settings, Select **[Return to Home]** in **Ethernet** menu. The MA-ETH will restart automatically. The changes you've made will take effect after the restart.

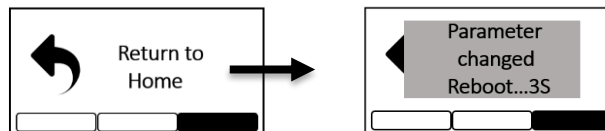

Figure 12.

The MA-ETH will execute the IP connection task. If the connection is successful, the yellow light in the upper right corner of the main page will change to green and the connection symbol will be displayed.

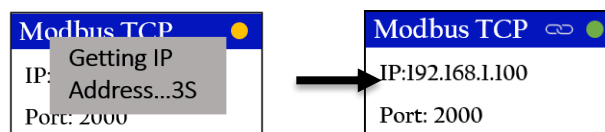

Figure 13.

4.4 Serial Port

Press ◀ or ▶ in the setting menu to select **[Serial Port]** to modify communication parameters. (Figure 14).

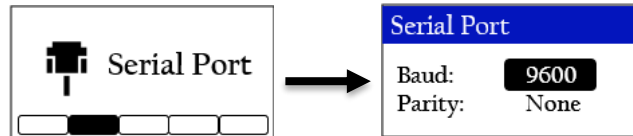

Figure14.

4.5 Rotate Screen

User can choose the display direction of the MA-ETH screen based on the installation in the field. Press ◀ or ▶ in the setting menu to select **[Rotate 180 deg]** to Rotate the screen 180°. (Figure 15).

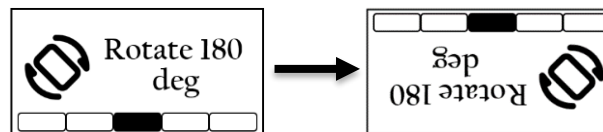

Figure15.

4.6 Device Information

Press ◀ or ▶ in the setting menu to select **[Info]** to view MA-ETH's hardware version and software version. (Figure 16).

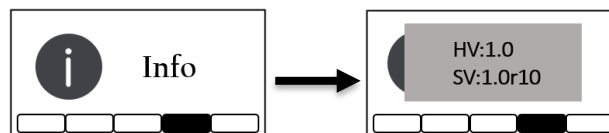

Figure 16.

5. Communication using Modbus TCP

The UC-50 controller is configured as a Modbus slave device. The probe information connected to the UC-50 can be obtained through the Modbus TCP connection. Contact Pyxis Lab Customer Service (service@pyxis-lab.com) for more information.

Register Address of Communication Parameters (writable)

Register address	Type	Byte order	Register definition
42001	Unsigned int 16	AB	Device Address(default:20)

Register Address of Measurement Parameters (read-only)

Register address	Type	Byte order	Register definition
46001-46002	float	CDAB	Free Chlorine
46003-46004	float	CDAB	pH
46005-46006	float	CDAB	Temperature
46007-46008	float	CDAB	Analog input

***Note*:** If the base address is 1, such as PLC system access directly according to the register address, if the base address is 0 system, the register address is reduced by 1 after access.

6. Contact Us

Pyxis Lab, Inc
 1729 Majestic Dr. Suite 5
 Lafayette, CO 80026 USA
www.pyxis-lab.com
 Phone: +1 (866) 203-8397
 Email: service@pyxis-lab.com