

MA-CIP-2 with LT-736 Series

Automatic Clean in Place Sensor Panel

Operation Manual



November 2021

General Information

In no event will the manufacturer be liable for direct, indirect, special, incidental or consequential damages resulting from any defect or omission in this manual. The manufacturer reserves the right to make changes in this manual and the products it describes at any time, without notice or obligation. Revised editions are found on the manufacturer's website.

Safety Information

Please read this entire manual before unpacking, setting up or operating this equipment. Pay attention to all danger, warning and caution statements. Failure to do so could result in serious injury to the operator or damage to the equipment.

To make sure that the protection provided by this equipment is not impaired, do not use or install this equipment in any manner other than that specified in this manual.

Use of Hazard Information



DANGER

Indicates a potentially or imminently hazardous situation which, if not avoided, will result in death or serious injury.



WARNING

Indicates a potentially or imminently hazardous situation which, if not avoided, could result in death or serious injury.



CAUTION





Indicates a potentially hazardous situation that may result in minor or moderate injury.

NOTICE

Indicates a situation which, if not avoided, may cause damage to the instrument. Information that requires special emphasis.

Precautionary Labels

Read all labels and tags attached to the instrument. Physical injury or damage to the instrument could occur if not observed.

	This symbol, if noted on the instrument, refers to the instruction manual for operation and/or safety information.
	This symbol, when noted on a product enclosure or barrier, indicates that a risk of electrical shock and/or electrocution exists.
	Delicate internal electronic components can be damaged by static electricity, resulting in degraded performance or eventual failure.
	Electrical equipment marked with this symbol may not be disposed of in European public disposal systems after 12 August of 2005. In conformity with European local and national regulations (EU Directive 2002/98/EC), European electrical equipment users must now return old or end-of-life equipment to the Producer for disposal at no charge to the user.

Catalogue

1. MA-CIP-2 Description	- 1 -
2. Specifications	- 3 -
3. Structure Description/Dimensions & Spare Parts	- 5 -
4. Installation and Connection	- 7 -
4.1. Installation Requirements	- 7 -
4.2. Equipment Installation	- 8 -
4.3. Electrical Connection	- 9 -
5. Touch Screen Operation	- 10 -
5.1. Initial Screen.....	- 10 -
5.2. User Login	- 10 -
5.3. Real-Time Monitoring	- 11 -
5.4. Menu Bar.....	- 13 -
5.5. Parameter Settings.....	- 14 -
5.5.1. <i>Alarm Parameter Settings</i>	- 14 -
5.5.2. <i>4-20mA Output Parameters Settings</i>	- 15 -
5.5.3. <i>Control Parameters</i>	- 16 -
5.5.4. <i>Cleaning Parameters</i>	- 17 -
5.5.5. <i>Communication Settings</i>	- 18 -
5.5.6. <i>Diagnostic Parameters</i>	- 19 -
5.6. Parameter Calibration	- 21 -
5.6.1. <i>Sensor Calibration (Turbidity used as example)</i>	- 22 -
5.7. Alarm Browsing	- 26 -
5.8. Historical Data	- 27 -
5.9. Historical Data Curve.....	- 29 -
5.10. User Management	- 31 -
6. Routine Maintenance	- 32 -
6.1. Mailing Address.....	- 32 -
7. Contact Us	- 32 -

1. MA-CIP-2 Description

The Pyxis MA-CIP-2 is a self-sufficient bypass 'Clean-In-Place' PLC based control panel specifically designed for use with Pyxis Lab inline sensors. This device may be used as a stand-alone display/data logging panel with automated Clean-In-Place control capability for applications where Pyxis inline sensors are exposed to heavy fouled water or process applications requiring a higher frequency of chemical cleaning. The MA-CIP-2 panel comes as a plug-and-play platform and is highly customized depending on the type and quantity of sensors purchased with the panel. The MA-CIP-2 includes one UC-100S 7-inch LCD capacitive touch screen display and data logging terminal capable displaying the input sensor values, trend graphs, sensor calibration and cleanliness diagnostics interface, input data storage, alarm output, remote data logging and easy programming for self-cleaning frequency and duration. MA-CIP-2 operates on 100-240VAC / 22W power supply and offers 2x 4-20mA, RS485 Modbus RTU and RJ-45 socket with TCP outputs. Equipped with ¾" NPT-CPVC plumbing, bypass isolation valves, recirculating pump, inline Pyxis sensors (selected and purchased separately), chemical injection port and chemical reagent pump and shelf, this unique platform enables users of Pyxis inline sensors to cost-effectively and rapidly integrate an automated cleaning cycle process for extended accuracy.

Any Pyxis inline sensors purchased with the MC-CIP-2 panel, will be terminated to the UC-100S display/data logger in RS-485 format. For Pyxis sensors offering 'cleanliness diagnostics' the RS-485 connectivity enables real-time cleanliness diagnosis/alarming of the sensor to automatically activate the bypass clean-in-place process. This unique differentiation of Pyxis inline sensors provides the user with a truly "automated" process to ensure optimum sensor cleanliness and accuracy at all times. For Pyxis sensors that do not offer 'cleanliness diagnostics' an event timer cycle may be programmed and used for sensor cleanings.

Typical Applications

A typical setup using MA-CIP-2 would be in a heavily fouled cooling or process water application containing organic or inorganic contaminants that rapidly deposit on the inline sensor. The MA-CIP-2 operates to isolate the sensor and apply / recirculate the proper chemical cleaning solution for a pre-set period then open the valves and allow the sensor to be returned to service.

Features

- 1 – UC-100S Touch Screen PLC w/Relay Control and 2x 4-20mA & RS-485 Input/Output
- 1 – Seko Chemical Feed Pump for Cleaning Reagent
- ¾ -inch NPT-CPVC Bypass Plumbing inline Pyxis Tee Assembly for ordered sensors premounted
- 2 – Normally Open Motorized Isolation Valves for Inlet and Outlet
- 1 – Normally Closed Motorized Isolation Valve for Recirculation Mode
- 1 - Recirculating Pump for Cleaning Solution
- 1 - Injection Tee Assembly for Chemical Dosing

LT-736 Series Sensor Description

The **LT-736** series are proprietary inline turbidity sensors offered in a range from 0.001 to 1,000 NTU with ultra-low resolution. Sensor format details are provided in the specification table of this document with options meeting ISO-7027 and EPA-180.1 compliance guidelines. The LT-736 series sensors offer a unique flat surface distal end in a quartz glass plate, allowing for extended cleanliness and easy maintenance and prevention of air bubble interference. This sensor is designed for optimal accuracy and performance in a wide range of turbidity water samples using 90° surface scatter configuration, installed in the MA-CIP-2 panel with the FT-100 Inline Tee making it highly versatile for a wide variety of drinking or industrial water applications. All LT-736 series sensors are offered in Warm White Light (LED) or InfraRed LED (860nm). They are powered by a 24 VDC/2W power supply and offer both 4-20 mA and RS-485 Modbus output signals. When clean, the unique Pyxis sensor design offers a calibration stability of <0.02NTU for up to 1-year of operation with no need for calibration. The LT-736 series sensor is connected to the UC-100S display via RS-485 digital communication for live sensor readings, diagnostics data and calibration interface. Additionally, the sensor can be wirelessly accessed via Bluetooth for Diagnostics, Cleaning & Calibration when using the **uPyxis APP** for mobile or desktop devices and the **MA-CR** Bluetooth Adapter as an optional accessory.



LT-736 Series Turbidity Sensor

FT-100 In-Line Tee Assembly Installations

The LT-736 series turbidity sensor is installed using the Pyxis **FT-100** in-line flow Tee assembly on the MA-CIP-2 panel. This uniquely designed in-line Tee operates at a maximum of 40 Liters/Min (10.6 GPM) flow rate and operating pressures as high as 6.9 bar (100psi). For consistent and precise turbidity measurement, the users should identify the optimum flow rate for the application of installation. This can be done by adjusting the inlet valve and regulating flow until the turbidity display on the UC-100S is consistent with little variation. The FT-100 flow tee is constructed of schedule 40-CPVC and designed with a unique 45° downward angle for extended sensor cleanliness and allows for users to install the LT-736 series in pressurized flow applications with limited space. This in-line Tee dramatically reduces the installation space requirement and is highly compatible with most by-pass sensor plumbing installations allowing the user to easily remove the sensor for cleaning and maintenance. The LT-736 series sensor flat distillate end is specifically designed to prevent air bubbles from accumulating when installed in the FT-100. For precise sensor calibration users should remove the LT-736 series sensor, clean it and conduct a near-zero and slope calibration using the L-CAL portable calibration kit and turbidity calibration standard solutions. See calibration section for details.



FT-100 In-Line Tee Assembly

2. Specifications

MA-CIP-2 Specifications

Item	MA-CIP-2 Clean-In-Place Panel
P/N	MA-CIP-2
Plumbing Format/Operation	¾" NPT / Sch 80 CPVC / 116psi (8Bar)
Inlet/Outlet Isolation Valves	Normally Open Motorized / 24 VDC / 5W / IP67
Circulation Isolation Valve	Normally Closed Motorized / 24 VDC / 5W / IP67
Recirculating Pump	Diaphragm Pump/ 1.3GPM@60psi / 24 VDC / 40W / IP44
Reagent Chemical Pump	Seko Solenoid Pump 110/220 VDA, IP65, 5 L/hr @ 116 PSI (8Bar)
Storage Temperature	32 - 120 °F (0 - 50° C)
Operational Temperature	32 - 120 °F (0 - 50° C)
Panel Dimension	Approximately 1,000mm H x 700mm W <i>Panel Sizes Will Vary Based on Quantity of Sensors Selected</i>
Panel Weight	Approximately 10kg (22lb) <i>Weights May Vary Based on Quantity of Sensors Selected</i>
Certificates	CE / RoHS Marked

UC-100S Specifications (included on MA-CIP-2 Panel)

Item	UC-100S
Power	110/220VAC 50/60 Hz, 30W
Display	7inch - 4 Wire Resistance Color Touch, 800 x 400 Resolution
Output	2 x 4-20 mA / RS-485 Modbus-RTU / Modbus TCP / 2 x Relay
Input	2 x 4-20 mA / RS-485 Modbus / 4 x Digital
Internet	RJ-45 socket, Modbus-TCP
Data Storage	4G, up to 1 million data entries or events
USB	1 x USB host, for data downloading and screen upgrade
Dimension (WxHxD)	15.7 in W x 11.8 in H x 6.7 in D
Weight	5 kg
Operation Temperature	32 – 122°F
Storage Temperature	14 – 140°F
Humidity	10 – 90% No Condensation
Protection	IP65
Regulation	CE / RoHS Marked

LT-736 Turbidity Sensor with FT-100 Inline Tee Assembly Specifications (included on MA-CIP-2 Panel)

Item	LT-736	LT-736B
P/N	53215	53223
Light Source (LED)	Warm White	860nm
Compliance	EPA180.1	ISO-7027
Range (NTU)	0.002 – 1000.00	
Accuracy Using FT-100	+/- 0.01 NTU or 2% <40NTU +/-0.05 NTU or 2% >40NTU	
Repeatability Using FT-100	+/- 0.002 NTU or 1% <40NTU +/-0.05 NTU or 1% >40NTU	
Calibration Stability	< 0.02 NTU/year drift (Assuming sensor is clean)	
Power Supply	22 – 26V DC, Power Consumption – 1.5W	
Outputs	Isolated 4 – 20 mA Analog Output & Isolated RS-485 Digital Output	
Wireless Access	Bluetooth Enabled with used w/ MA-CR or PowerPACK Adapters	
Installation	FT-100 In-Line Tee with 1.5" NPT Glue & Thread	
Weight	800 Gram (2.1 lbs – Sensor Only)	
Operational Pressure	LT-73X Series Sensors up to 100 psi (6.9 Bar) FT-100 Inline Tee up to 100 psi (6.9 Bar)	
Operating Sample Temperature	1-50°C (33.8 – 131°F)	
Sample Flow Range	LT-73X Series Sensors = 0 – 40 L/min (0-10.6 GPM) FT-100 Inline Tee = 0 - 40 L/Min (0-10.6 GPM)	
Recommended Flow Rate	Application Specific Set Through Inlet Valve Adjustment Until Sensor Stable	
Wet Material	LT-73X Series - 304 Stainless Steel / PVC & Polycarbonate	
Cable Length	Standard MA-4.9CR Cable (8Pin Adapters – 4.9ft) Flying Lead MA-1.5CR Cable (8 Pin Adapter / Flying Leads – 1.5ft)	
Calibration Options	LT-SOLID-CAL Solid State Calibration Kit for Repeatable Liquid-Less Calibration L-CAL Portable Turbidity Kit using Formazin Standards & DI Water	
Rating	IP67 - Sensor	
Regulation	CE / RoHS Marked	
Dimension	189mm (7.4inch) Length x 36mm (1.44inch) Body Diameter	

3. Structural Description/Dimensions & Spare Parts

The MA-CIP-2 panel is a truly customized solution and dimensions, weights and layout will vary depending on the quantity and type of Pyxis Lab inline sensors that are purchased for installation on the panel. Pyxis Lab manufactures the panel as a complete product in house with the sensors purchased and a formal diagram/drawing will be made available to the client upon shipment of the panel based on the sensor solutions ordered. Below is an example of the MA-CIP-2 panel with the Pyxis LT-736B inline turbidity sensor. This is for representation purposes only and final design will vary base on each unique application.

MA-CIP-2 Stuctural Design *(Precise Layout will vary on sensors selected)*

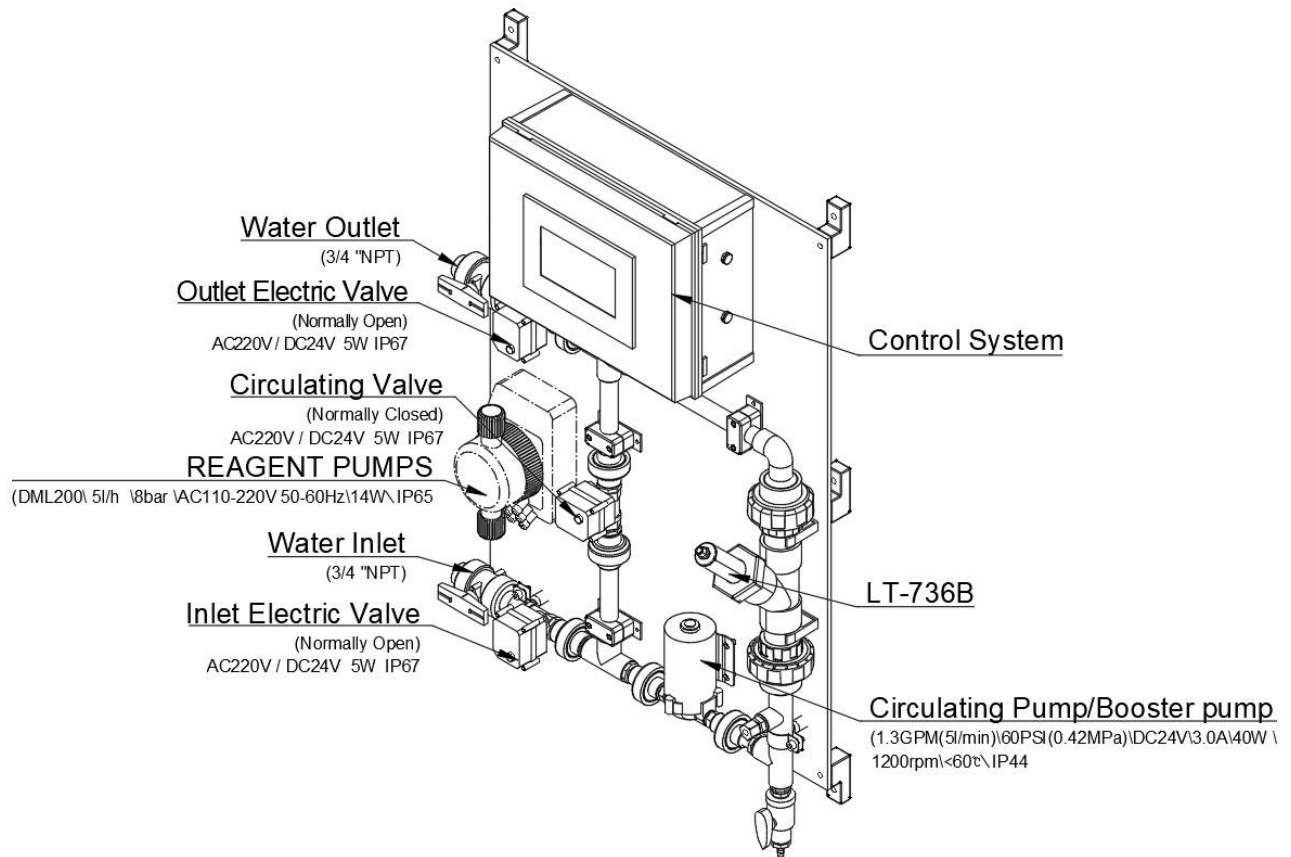

Figure 1 – MA-CIP-2 Typical Panel Diagram - Precise Layout will depend on user selected sensors

MA-CIP-2 Spare/Replacement Parts

The MA-CIP-2 panel spare parts may be referenced in the table below. Please contact Pyxis Lab Inc. for pricing and order information on these items.

Item Name	Part Number	Description
Inlet/Outlet Electric Valve (2)	44024	Valve Normally Open Motorized / 24 VDC / 5W / IP67 / ¼ inch NPT
Circulating Electric Valve (1)	44025	Valve Normally Closed Motorized / 24 VDC / 5W / IP67 / ¼ inch NPT
Circulation/Booster Pump (1)	52607	Circulation Diaphragm Pump/1.3GPM@60psi / 24 VDC / 40W / IP44
Seko Chemical Feed Pump (1)	Contact Pyxis	Chemical Pump Seko AML-200/5L-hr/120psi/100-240VAC/IP65

UC-100S Display/Data Logging Terminal Dimensions

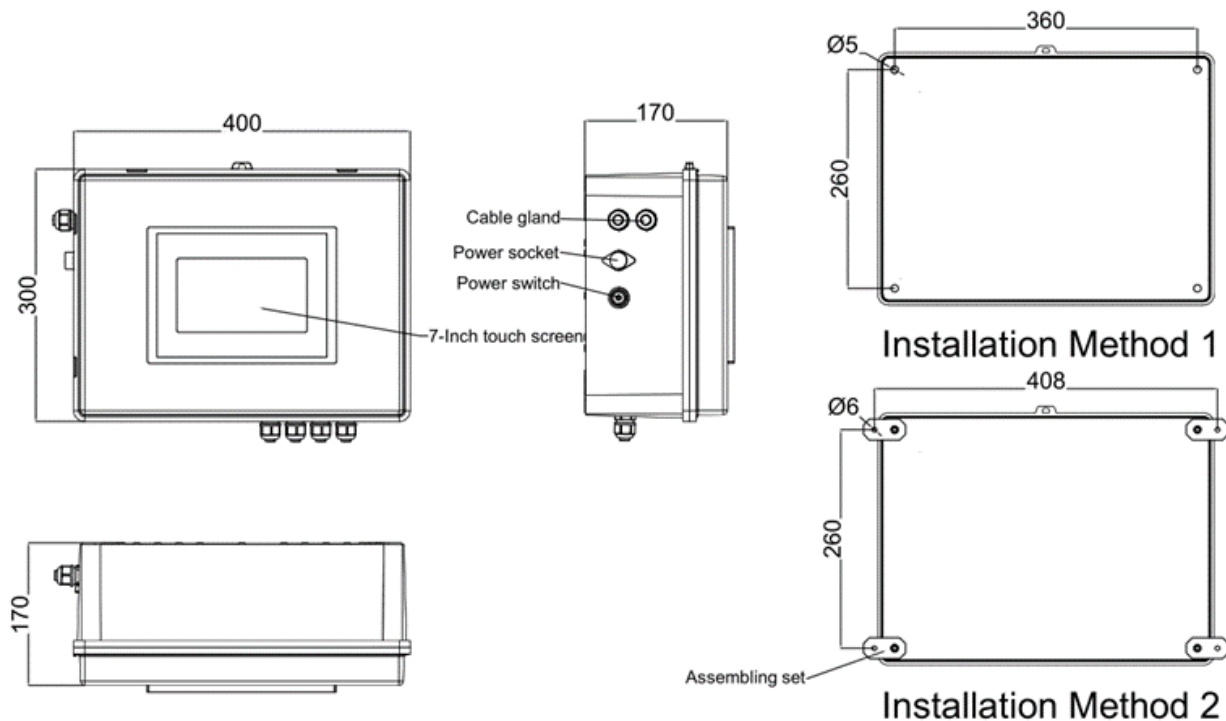

4. Installation and Connection

4.1. Installation Requirements

Power Supply: 100~240V AC 50/60Hz; lead wire into the device installation point should be within 0.5 meters.

Sample Water Supply: Inlet $\frac{3}{4}$ - inch FNPT with pressure no less than 15psi and no greater than 60psi. Flow should be regulated by the user at the point of application until the sensor reading is stable and consistent. Once achieved, this flow should be consistently maintained.

Sample Water Outlet: Outlet $\frac{3}{4}$ - inch FNPT should be diverted to a lower pressure receiving line or sump.

Equipment Installation: Wall-mounted installation of MA-CIP-2. Typical panel size is approximately 1,000mm in Height and 700mm in Width and requires a wall flatness less than 0.5cm/m². ****NOTE*** the MA-CIP-2 panel dimensions are subject to change depending on the quantity and type of Pyxis sensors selected for the panel design.*

Equipment Weight: Approximately 10kg panel weight should be mounted fixed on the wall with expansion screws. At least 0.5m operation space is reserved around the equipment installation. ****NOTE*** the MA-CIP-2 panel weights are subject to change depending on the quantity and type of Pyxis sensors selected for the panel design.*

3G/4G Network Signal: If the MA-CIP-2 is to be connected to a modem or wireless gateway, the 3G/4G network signal in the area of equipment installation area should be verified and normal. (ie. mobile phones on site can receive calls and surf the Internet normally)

4.2. Equipment Installation

It is recommended to select a water inlet point close to the ideal sampling point of the system for easy installation and maintenance. Prepare and install expansion screws on a solid wall prior to installation.

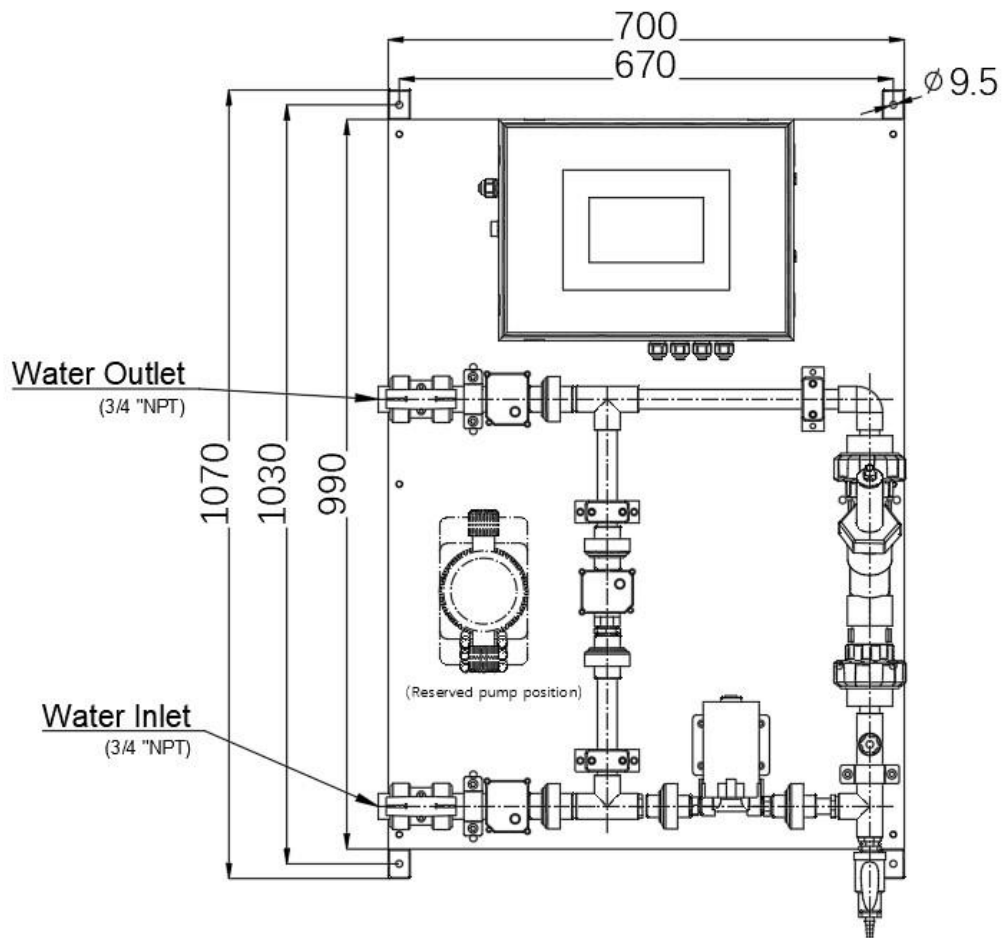

Figure 1 - MA-CIP-2 Typical Equipment Installation Diagram (may vary based on sensors selected)

4.3. Electrical Connection

The MA-CIP-2 power plug should be plugged into a power socket of 100~240V AC 50/60Hz for normal operation. ***NOTE*** the 4-20mA output terminal highlighted below as Turbidity is represented for example purposes only. This output designation will vary depending on the sensors selected for installation on the MA-CIP-2 by the client.

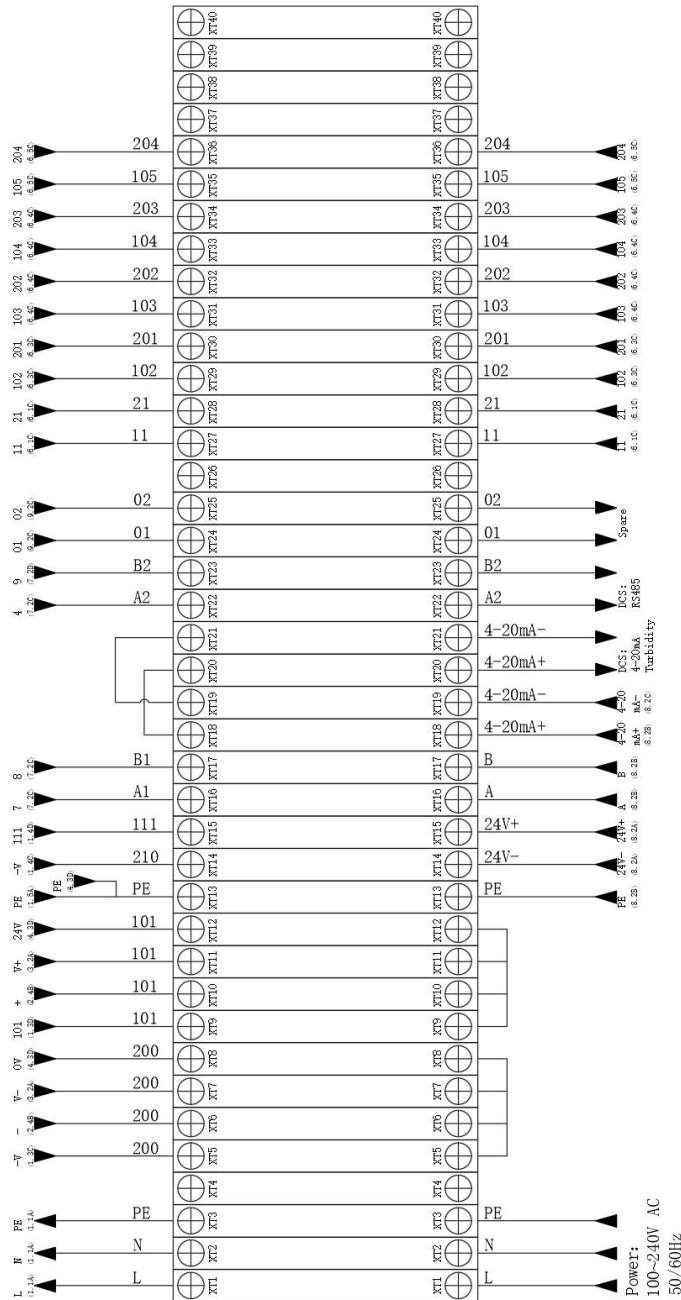

Figure 2 - Terminal Wiring Diagram

⚠ All contact with the 220V single-phase power supply should be conducted by a certified electrician. Failure to follow the electrical operation specifications may cause electric shock injury or even death.

5. Touch Screen Operation

5.1. Initial Screen

After the system is powered on, the screen will open the initial screen, where the user can select the user to log in or enter the system. ***NOTE*** the initial screen dialog will vary depending on the sensors selected for installation on the MA-CIP-2 by the client. In this example, Turbidity was the sensor selected.

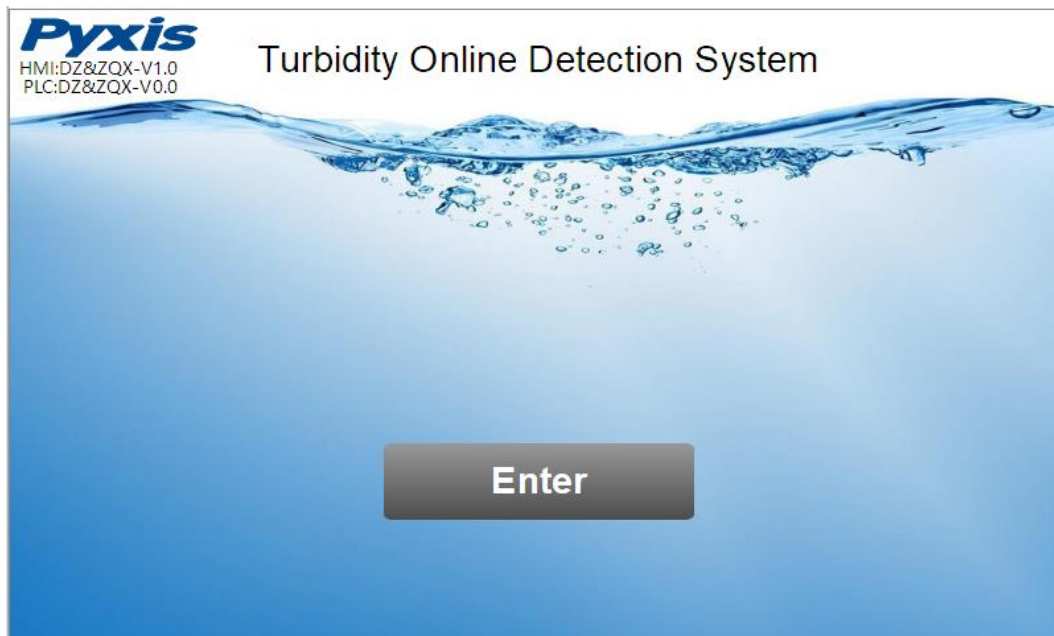

Figure 3 - Main Screen Interface

5.2. User Login

After startup, the user needs to log in with the user name and password, otherwise they can only view the reading on the main interface, and cannot perform instrument parameter settings and calibration. Click the "User Login" button, a prompt box pops up: select the user "**pyxis**", enter the password: "**888888**" in the user password field.

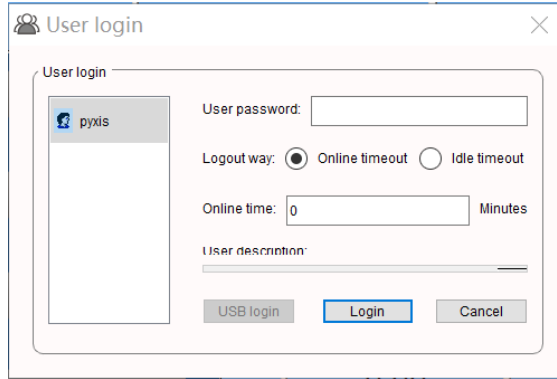

Figure 4 - User login Interface

If you don't need a password or want to change the user, you can enter the system and perform "management" in the "user management" interface of the menu.

5.3. Real-Time Monitoring

Click the "Enter System" button on the main interface to enter the real-time monitoring screen of the system, where the data detected by the sensor within 15 minutes will be displayed in real time.

Figure 5 - Real-Time Monitoring Screen (Turbidity Is Used as the Example Sensor)

No.	Real-Time Monitoring Screen Features
1	The blue area on the top of the screen will scroll the alarm information in real time. After the alarm occurs, please handle it according to the content in time
2	The white center area will display the value of each sensor in real time
3	The bottom left area shows the operational status of circulating pump and electric valve. The bottom right side shows the control status of cleaning system.

In the Cleaning ‘Control Mode’ interface, you can select the mode of the self-cleaning system as manual/automatic. When the Cleaning ‘Control Mode’ is changed to manual, each electric valve and pump can be opened and closed individually. ***NOTE*** For Pyxis inline sensors that offer self-cleanliness diagnostic capability such as inline fluorometers (ie. ST-500), the automated cleaning control mode may be programmed on sensor cleanliness factor (Threshold) or on a timer basis, or both. For Pyxis sensors not offering self-cleanliness diagnostic capability (Threshold) the automated cleaning control mode will be timer based only. Please contract Pyxis Lab to determine which Pyxis sensors offer the self-cleanliness diagnostic capability.

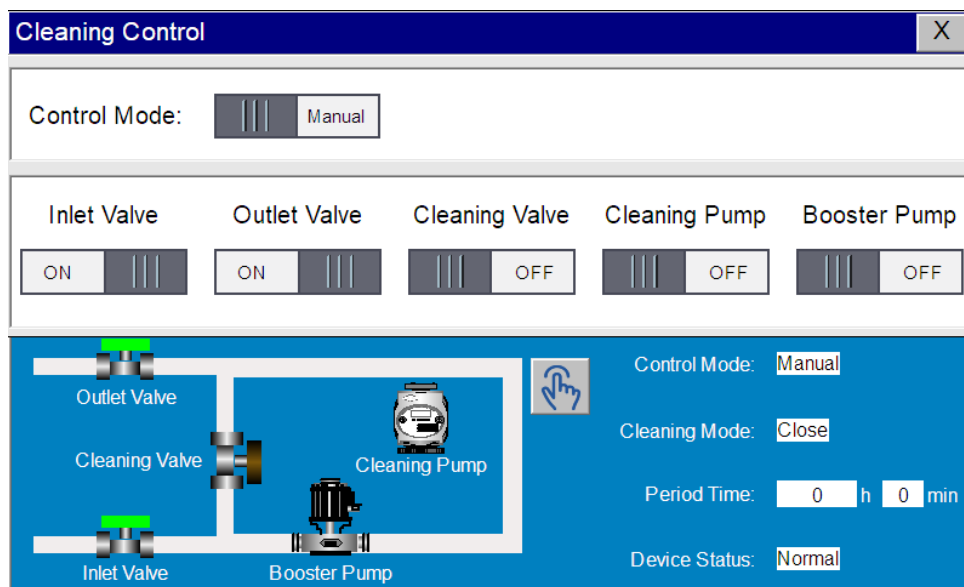



Figure 6 - Cleaning ‘Control Mode’ Screen

5.4. Menu Bar

Click the "  " button in the upper left corner of the screen to enter the system menu interface, where the user can choose to enter the desired operation interface.

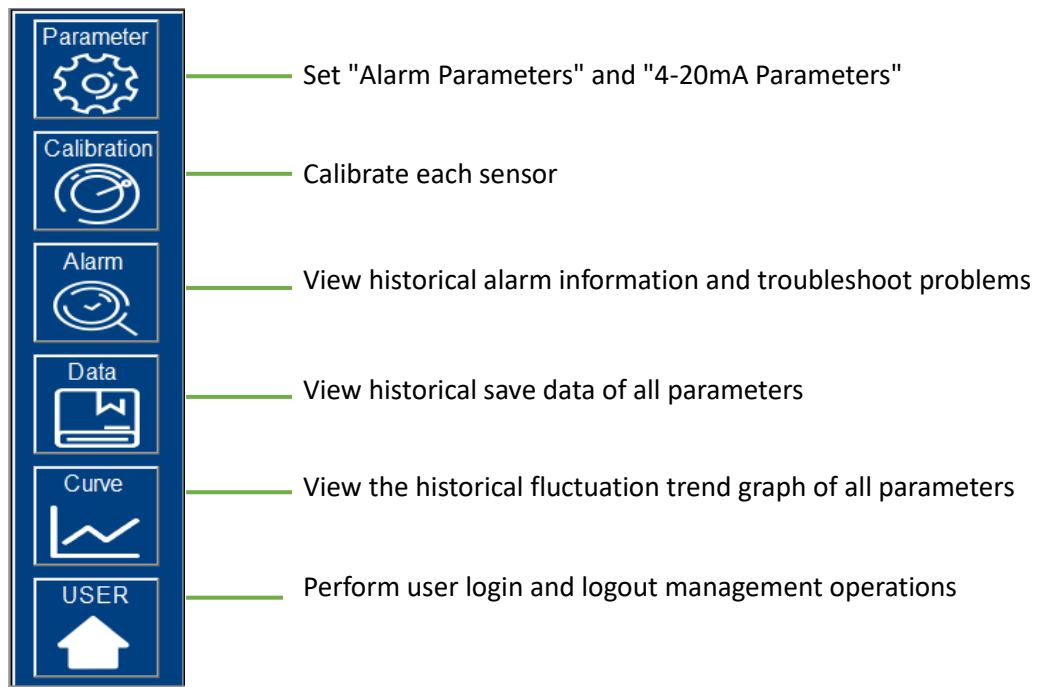

Figure 7 - Menu Bar

5.5. Parameter Setting

Click the "Parameter" button in the menu bar, you can choose to enter the "Alarm Parameters", "Control Parameters" and "Cleaning Parameters" setting interface:

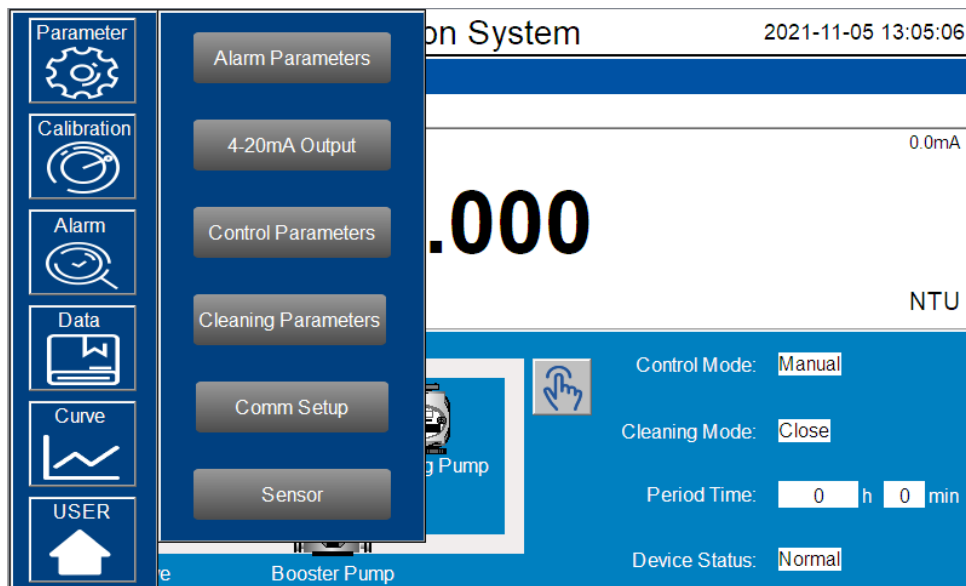

Figure 8 - Parameter Settings

5.5.1. Alarm Parameter Settings

When the online user has access to the Alarm Parameter Settings, the upper and lower alarm limits can be set. Click "Alarm Parameter " to enter the interface of alarm parameter settings. Here you can set the alarm upper limit and lower limit of each sensor. When the measured value is lower than the set lower alarm limit, the real-time monitoring screen "XX lower limit alarm" prompt of the corresponding sensor will be displayed. When the measured value is greater than the set upper limit value, the "XX upper limit alarm" prompt of the corresponding sensor will be displayed on the real-time monitoring screen. Users can also select to turn ON or OFF the alarm display function in the upper left of the corresponding parameter list.

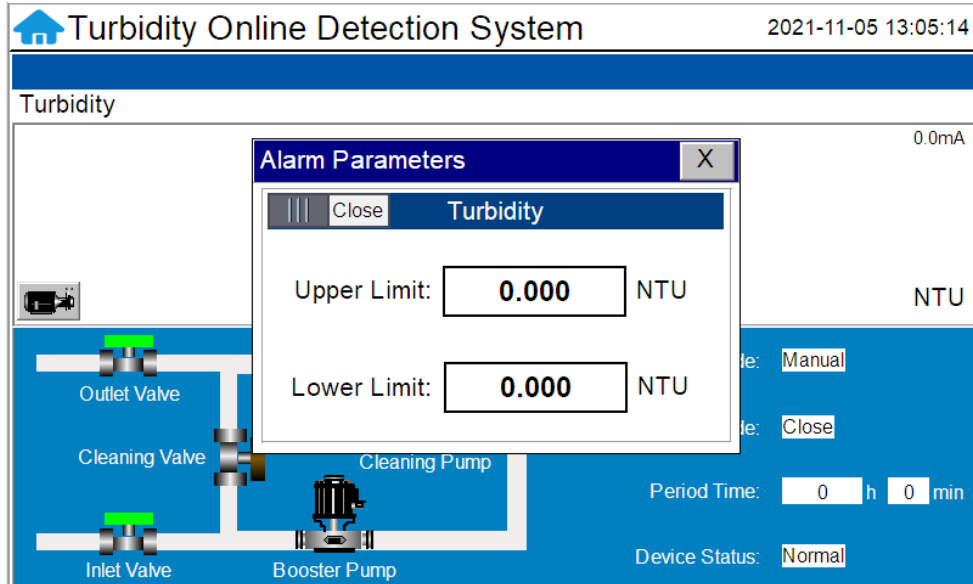

Figure 9 - Alarm Parameter Setting Screen

5.5.2. 4-20mA Output Parameters Setting

Click "4-20mA Output " to enter the 4-20mA output parameter setting interface. The 4mA and 20mA output values should correspond to the lower and upper limits of the selected sensor range. ***NOTE*** The closer the value is set to the measurement value of the sensor the more accurate the output data.

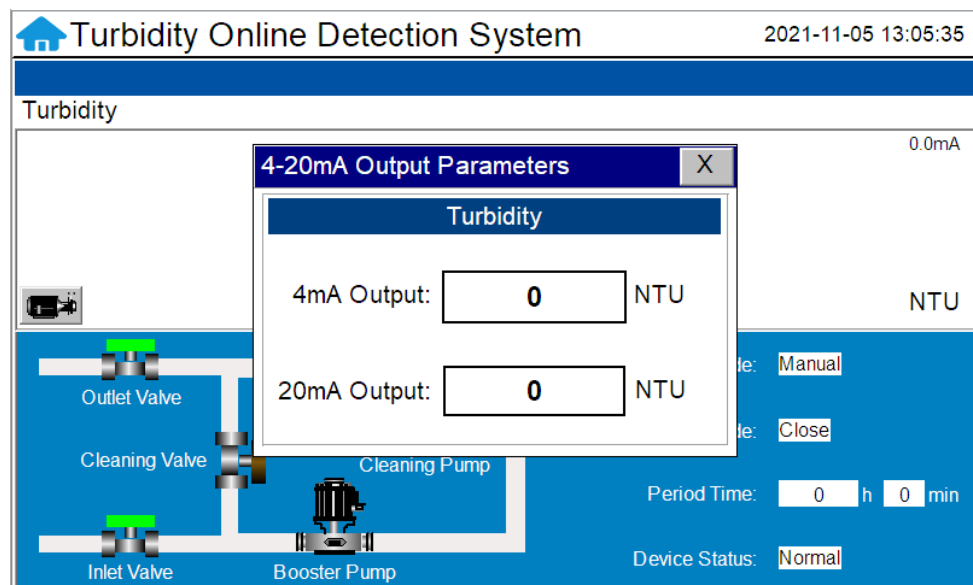

Figure 10 - 4-20mA Output Setup Screen

5.5.3. Control Parameters

Click "Control Parameters" to enter the Cleaning Control Interface. Here the user can choose automatic cleaning or manual cleaning control mode.

Control Parameters Description

Cleanliness – Users may choose to display the sensor cleanliness as a percentage value for Pyxis sensors that offer this feature only (*ie. Inline Pyxis fluorometers*).

Control Mode - Displays the control status of the Clean-In-Place circulatory system, auto or manual. Cleaning mode is divided into 3 modes.

- **Close** = When the system cleaning state is off, the cleaning system mode will be 'close'.
- **Cycle** = When the system cleaning state is periodic, the system will be cleaned at a preset periodic time and displayed as 'cycle'.
- **Threshold** = When the control mode is threshold, the system will begin cleaning after the sensor cleanliness value reaches the preset sensor cleanliness threshold. (*limited to specific Pyxis fluorometers – contact Pyxis Lab to determine if your sensor has self cleanliness diagnostics*)

Device Status - Displayed as normal, cleaning and protection.

- **Normal** = When the system is not cleaning.
- **Cleaning** = When the equipment starts cleaning.
- **Protection** = When the cleaning time exceeds the preset protection time equipment will automatically jump to the protection state. While in the protected state, the customer needs to manually change the mode back to normal before the self-cleaning system can be restarted.

Communication Protection – is divided into normal and stop. When the cleaning is complete, the communication protection time enters the countdown and then the communication will be reconnected. This feature allows the communication to be put on hold during the chemical cleaning process and avoid erroneous data log.

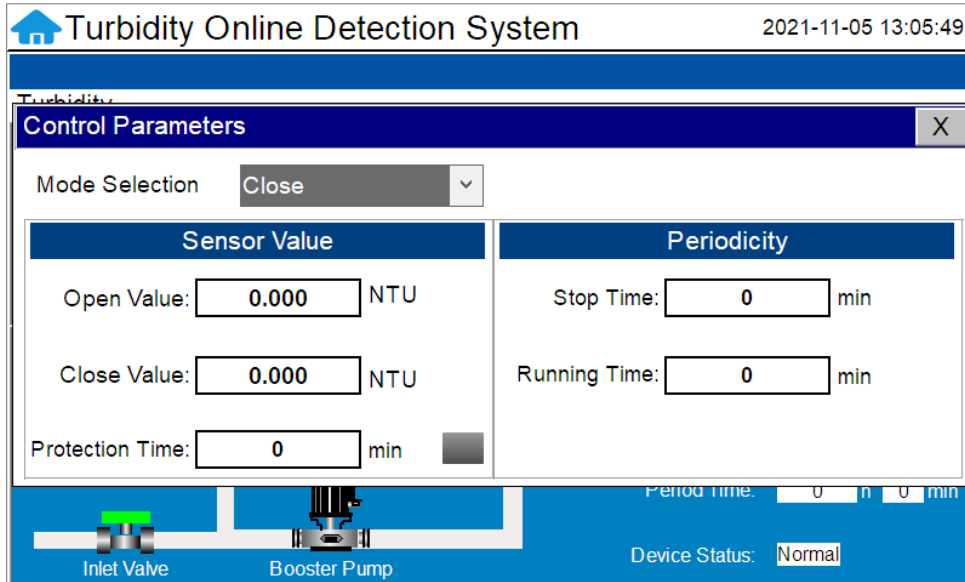

Figure 11 - Control Parameters Screen (Turbidity Sensor used as Example – No Cleanliness Diagnostics)

5.5.4. Cleaning Parameters

Click the “Cleaning Parameters” and enter the cleaning control parameter interface. Here users can choose the cleaning control process. Customers can set the cleaning cycle periodicity (frequency) time. Once the periodicity (frequency) of the cleanings has been programmed, user can program the Run Time Parameters for the cleaning cycle. This includes the chemical cleaning pump time in seconds, the cleaning valve actuation in seconds and communication protection time in seconds based on desired need.

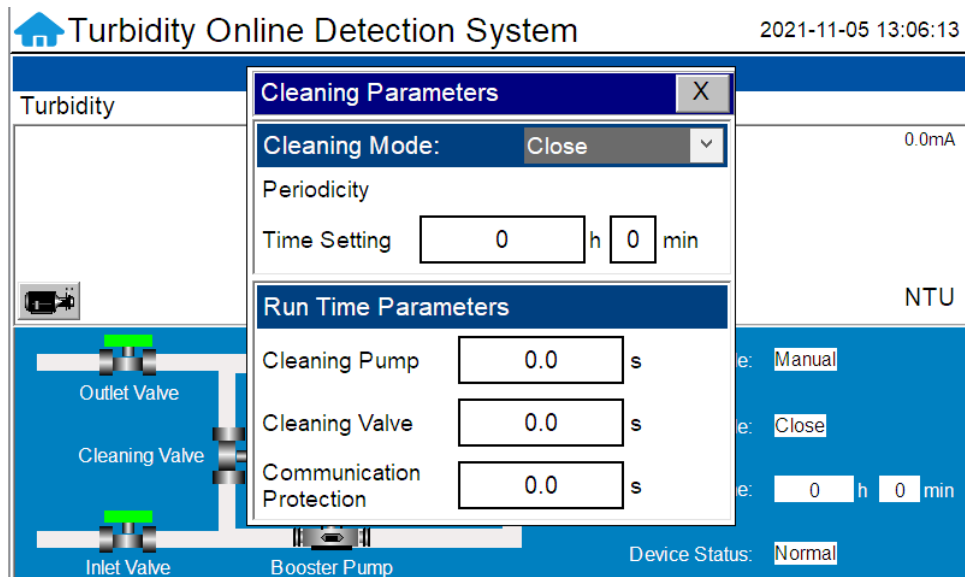

Figure 12 - Cleaning Parameter

5.5.5. Communication Settings

Enter the “CommSetup” tab to access the communication settings page. DCS/Network communication parameters generally do not need to be changed. If the DCS/Network communication station numbers and other parameters need to be changed on site, they can be changed in this interface.

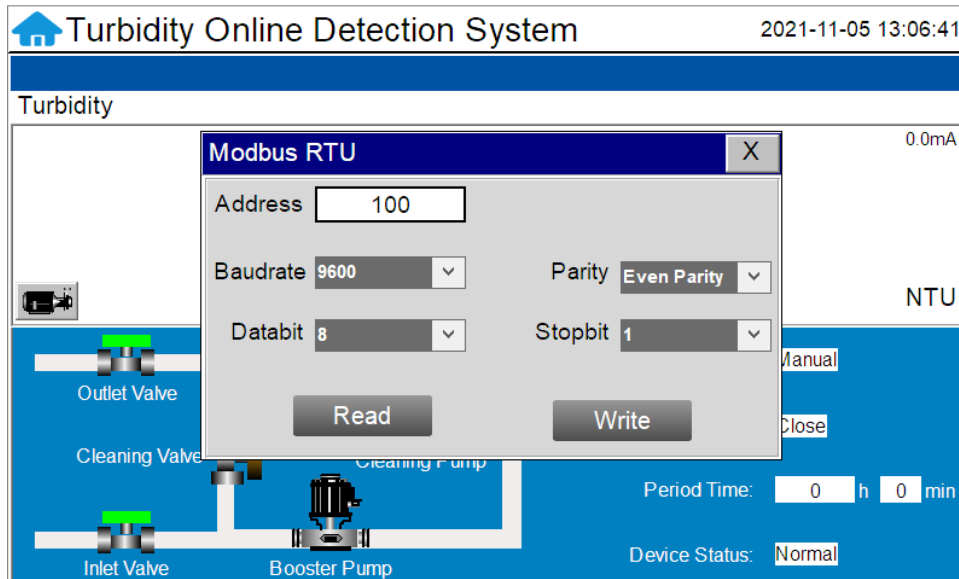

Figure 13 - Modbus RTU Setting

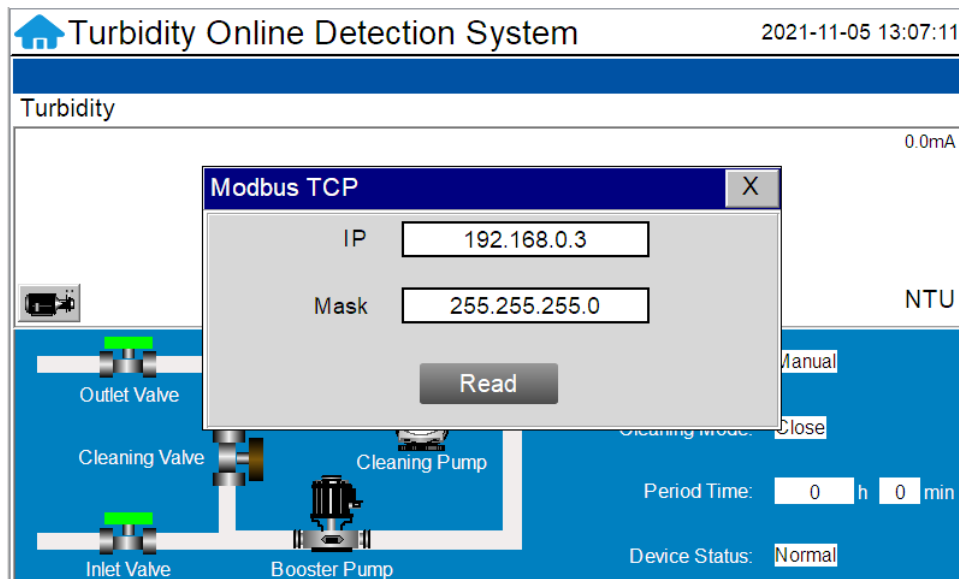

Figure 14 - Modbus TCP Setting

5.5.6. Diagnostic Parameters

Click “Sensor” then click “Diagnostic Parameters” to launch the diagnosis page to access the raw data measured by the probe. To help troubleshooting possible issues with the probe, please save an image of this data when the probe is placed in a clean water (tap water or deionized water), in a calibration standard and in the sample that the probe is intended for. ***NOTE*** *LT-73X series sensors MUST be installed in the FT-100, FR-100 or L-CAL Portable Calibration Kit vessel with the known standard solutions in order to get accurate diagnostic data. This is due to the unique sensor optical design which must be shielded from any ambient light.)*

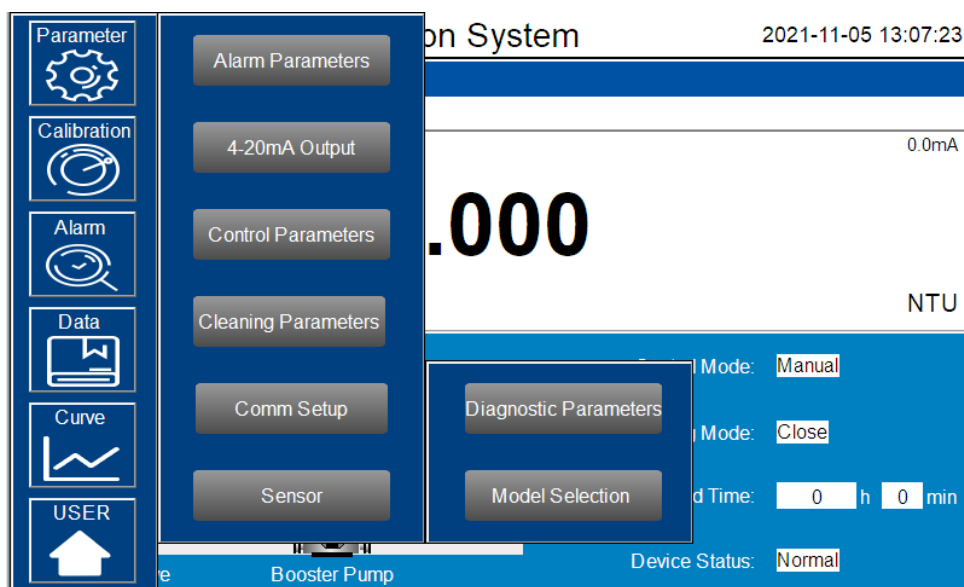

Figure 15 - Sensor Setting

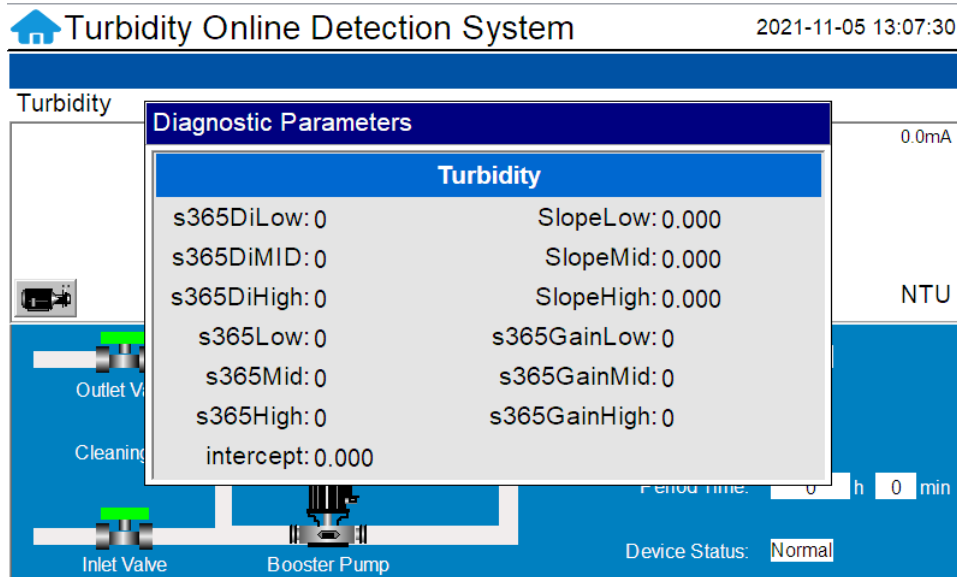

Figure 16 - Diagnostic Parameters for connected Sensor

If an alternative sensor needs to be selected, click the “Model Selection” button to enter the selection interface and select the corresponding name of the new sensor.

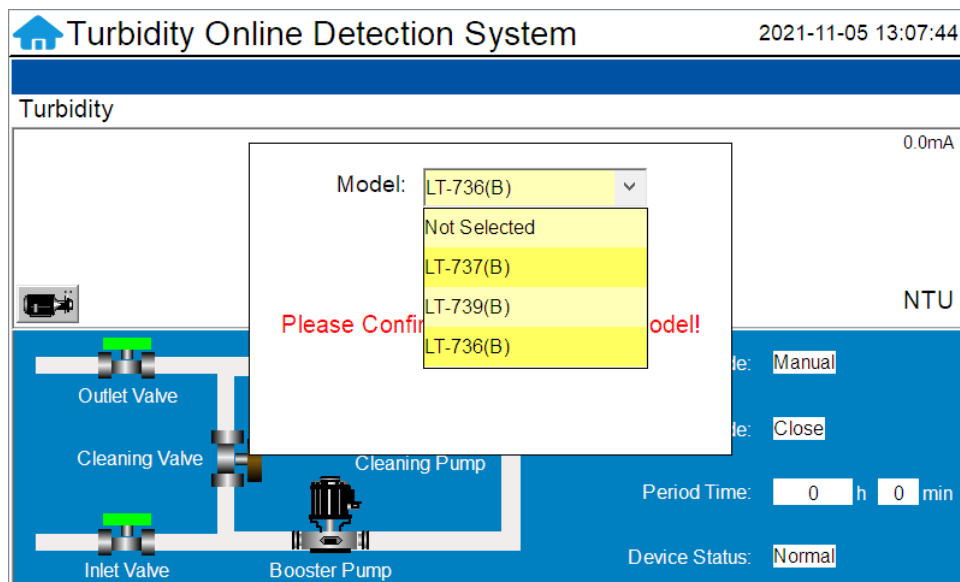

Figure 17 - Select Sensor Model from Dropdown List

5.6. Parameter Calibration

Click the "Calibration" button in the menu bar and then select the sensor to be calibrated. Once selected, you may conduct a one-point (slope only) calibration or a two-point (near zero and slop) calibration using the L-CAL Liquid Portable Calibration Kit as outlined in Section 5.6.1 of this manual.

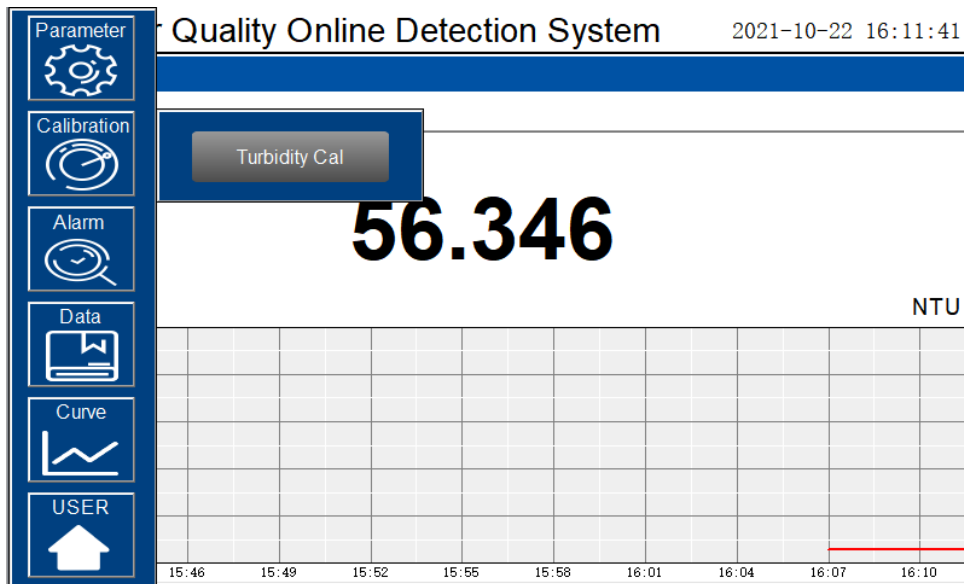

Figure 18 - Parameter Calibration

5.6.1. Turbidity Calibration Using L-CAL Liquid Portable Calibration Kit for LT-73X Sensors

Pyxis Lab has developed a portable and reusable liquid-state turbidity calibration kit for rapid calibration of the all LT-73X Series inline ultra-low turbidity sensors. The L-CAL calibration kit allows users to calibrate all LT-73X Series ultra-low turbidity sensors using smaller volumes of Formazin turbidity calibration standards providing an affordable and reusable solution for long term sensor reliability. The unique design of the L-CAL liquid calibration kit allows the LT-73X sensor to be easily inserted and calibrated with the sensor in a horizontal position, allowing air bubbles to be evacuated through the integrated air-vent line ensuring superior accuracy of the sensor calibration. The L-CAL has an easy to remove lid allowing users to fill and empty the calibration kit with DI water for vessel/sensor cleaning and Formazin calibration standards for sensor calibration.



L-CAL Liquid Turbidity Calibration Kit (P/N 53247)

Turbidity Calibration Principals & Considerations

The precision, resolution and the low detection limit of the LT-73X Series sensors are not affected by the calibration method, regardless of using certified Formazin standards and the L-CAL kit. The calibration only affects the turbidity sensor accuracy. The nature of turbidity measurement makes an absolute turbidity value not easily obtainable for any sensor manufacturer although proper standards and methods are followed. For example, turbidity values greater than 1.0 NTU measured on real-world samples with different sensors, even from the single manufacturer, could differ significantly. For ultra-low turbidity (less than 0.3 NTU) measurement using the same methods (ISO-7027 or EPA-180.1), it is likely that the values from different sensors can agree within 0.05 NTU. As such, the user should choose a calibration method and remain with the same calibration method for consistency.

L-CAL Specifications and Suggested Formazin Standard Solutions for LT-736 Series

Item	L-CAL Portable Liquid Formazin Calibration Kit
P/N	53247
Sensor Name	LT-736 / LT-736B
Calibration	Recommended Calibration Standard Solution Range
Low-Range (0.05NTU Recommended for Calibration)	Bubble Free DI Water or Sample <0.1 NTU
Mid-Range 1	5 – 10 NTU
Mid-Range 2	25 – 50 NTU
High-Range	500-1000 NTU

LT-736 Turbidity Calibration Procedure Using L-CAL

Proper calibration of Pyxis Lab LT-736 series inline turbidity sensor should be conducted with the **L-CAL Liquid Portable Turbidity Calibration Kit** (P/N 53247) as illustrated and outlined below. *(All non-turbidity Pyxis sensors may be calibrated in an open beaker with standard solution and do not require the L-CAL Kit. Contact Pyxis Lab for details on the L-CAL Portable Calibration Kit)*

One-Point Calibration

Close the MA-CIP-2 water inlet valve and drain the water from the pipeline. Remove and rinse the sensor with deionized water 2-3 times then gently wipe with a soft cloth to ensure all deposits and particulate are properly removed. Fill the L-CAL Portable Turbidity Calibration Kit vessel with formazin turbidity calibration standard solution (between 500 and 1000 NTU) and enter the value of the standard solution in the "High Range Standard Solution" screen then click the "Calibration" tab. A calibration success pop-up box will appear if calibration is successful. ***NOTE*** *Please refer to the suggested Formazin standard solution range for high-range calibration found in the table on the previous page of this manual).*

Two-Point Calibration

Close the MA-CIP-2 water inlet valve and drain the water from the pipeline. Remove and rinse the sensor with deionized water 2-3 times then gently wipe with a soft cloth to ensure all deposits and particulate are properly removed. Then fill the L-CAL Portable Turbidity Calibration Kit vessel with with deionized water and click "Calibration" under the "Low Range Standard Soltuion" to start the zero calibration. Remove and rinse the sensor 2-3 times with deionized water. Fill the L-CAL vessel with formazin turbidity calibration standard solution. If using the "Mid Range Standard Solution 1" please use a formazine solution between 5 and 10NTU. If using the "Mid-Range Standard Solution 2" tab please use formazine solution between 25 and 50 NTU. Either Mid-Range may be used based on user preference. Then click the "Calibration" tab. A calibration success pop-up box will appear if calibration is successful. ***NOTE*** *Please refer to the suggested Formazin standard solution range for high-range calibration found in the table on the previous page of this manual).*

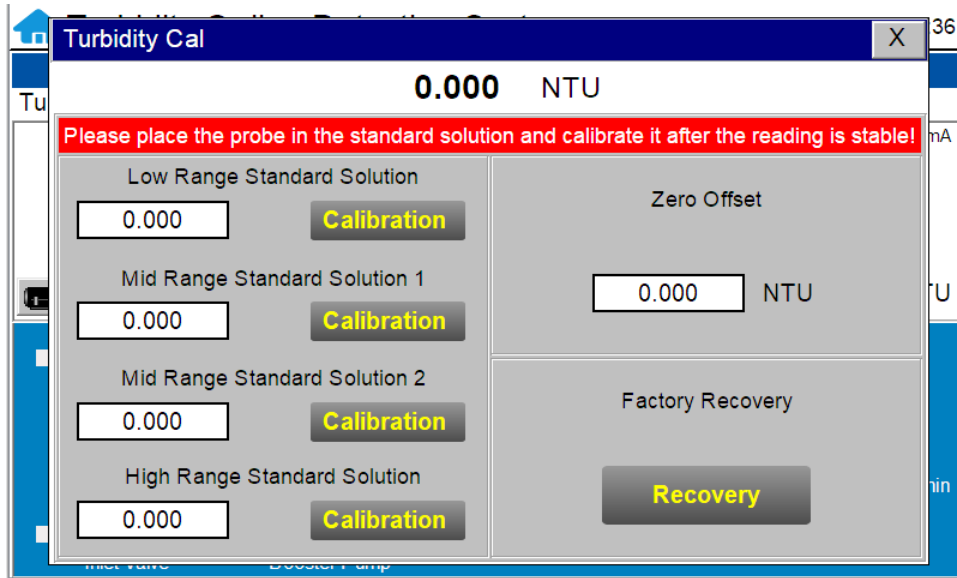

Figure. 19 Sensor Calibration Screen 1 – (Turbidity Used as Sensor Example)

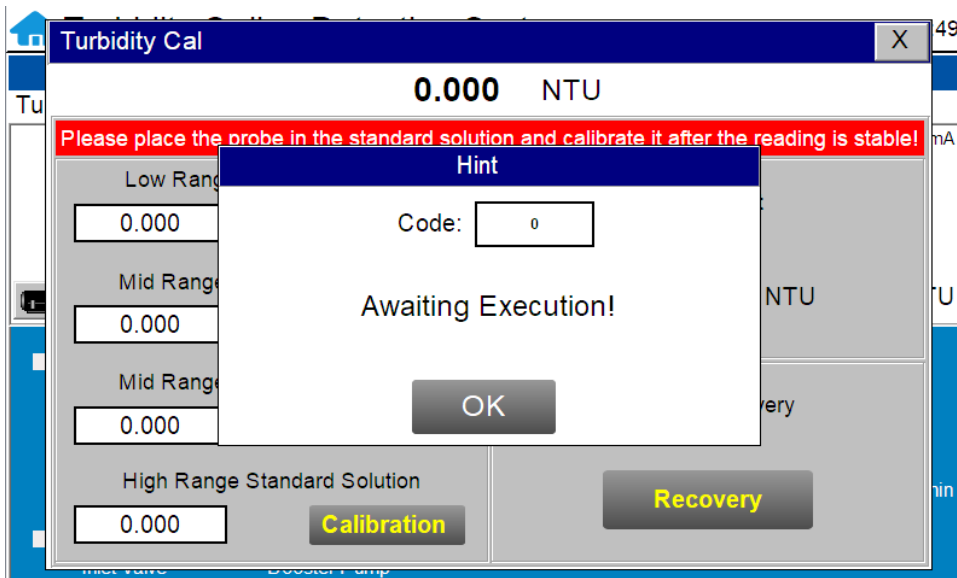

Figure 20 - Sensor Calibration Screen 2 - (Turbidity Used as Sensor Example)

L-CAL Portable Liquid Formazin Calibration Kit Use Method

After removing the LT-73X sensor, gently wipe off the flat distal end with a soft cloth to ensure it is clean. The LT-73X Sensor should then be calibrated using the L-CAL portable liquid calibration kit using the following steps, and wirelessly calibrated via the uPyxis Mobile or Desktop APP. Please refer to LT-73X Series Operation Manual for details.

Insert LT-73X Sensor



Tighten Sensor Nut



Position Vertically and Remove Lid



Preclean by adding DI-Water (200mL)



Insert Lid



Gently Shake Then Empty Contents



Add Calibration Standard (500mL)



Insert Lid and Remove Air Bubble Vent Line Cap



FOLLOW
CALIBRATION
STEPS

**NOTE* Sensor Brace Included with L-CAL Kit for Stability*



WATCH PROCEDURE VIDEO <https://www.youtube.com/watch?v=1MuJM5Q5VB4>

5.7. Alarm Browsing

Click the "Alarm Browsing" button. In this interface, the user can browse all alarm signals. Drag the right scroll bar up and down to view historical alarm records. You can also click "Previous" and "Next" to turn pages quickly. Click Query, enter the number in the pop-up box and query and you can quickly view the alarm details associated with the corresponding number. After clicking the delete button in the lower left corner, all alarm records will be deleted. Upon exit of this screen the historical data in the data report will be cleared.

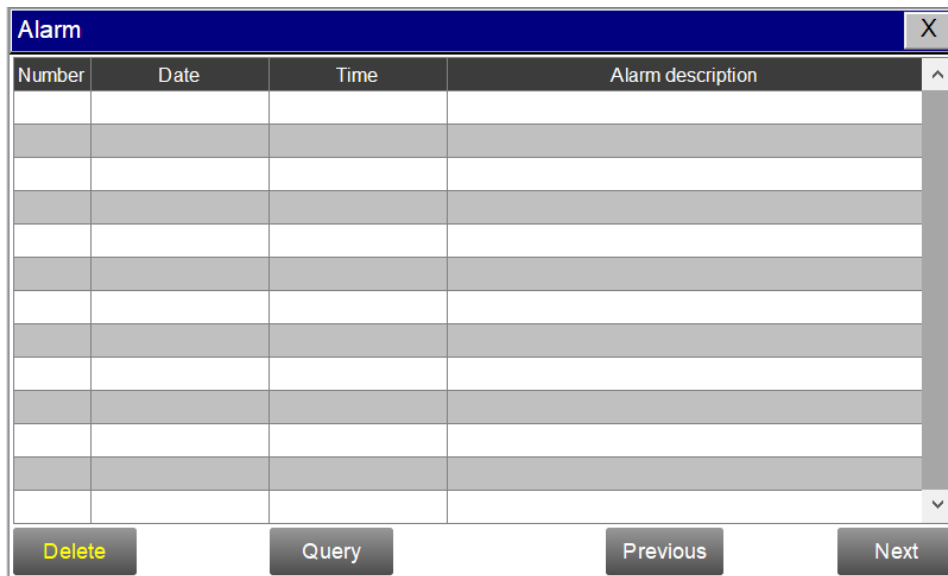

Figure 21 - Alarm Browsing

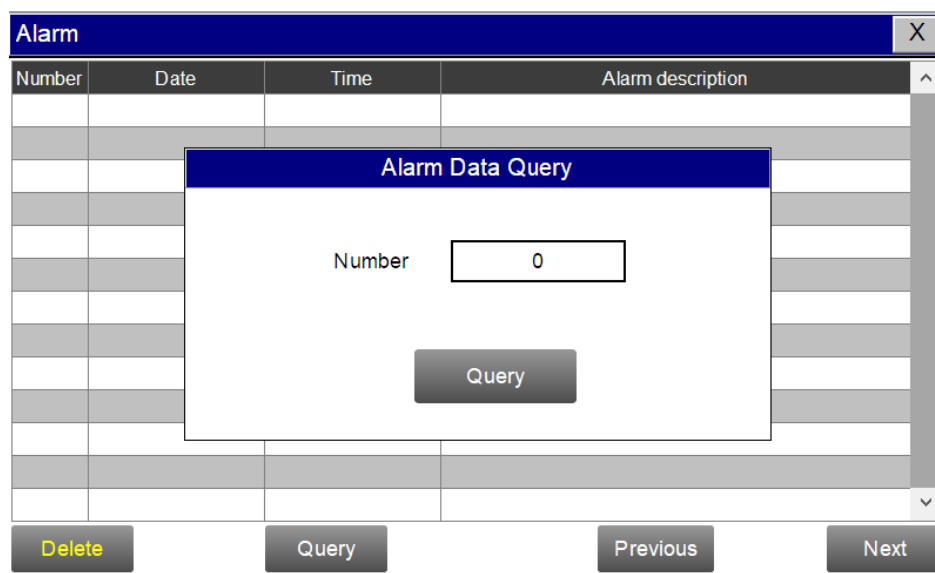

Figure 22 - Alarm Data Query Interface

5.8. Historical Data

Click the "Historical Data" button in the menu bar to enter the data report interface.

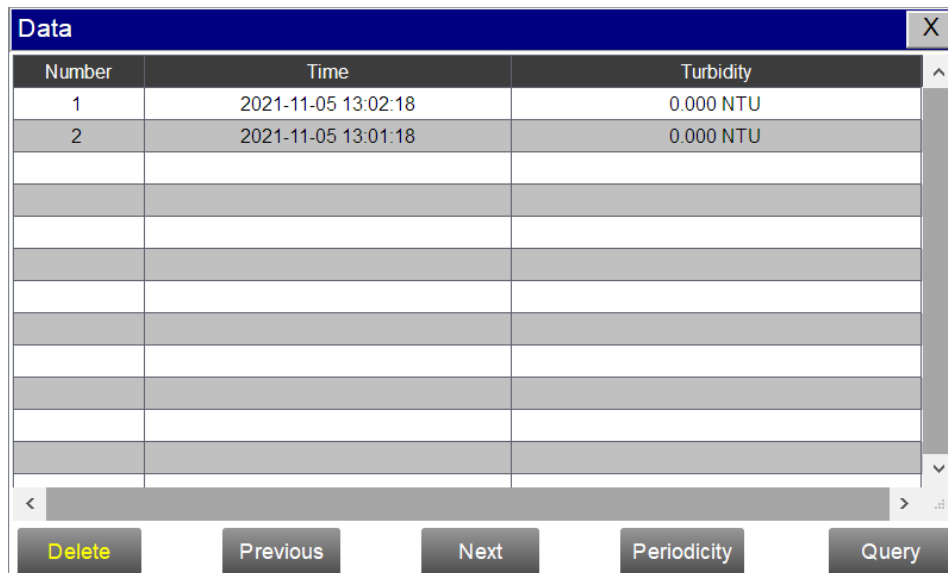

Figure 23 - Historical Data Interface

In the data report, the user can view the stored data of all parameters. The system records sensor readings every 4 seconds by default. Drag the scroll bar on the right to slide up or down, or click "Previous" and "Next" to view historical data records. The data record can save 100,000 pieces of data, and more than 100,000 will overwrite the previous data. The user can click the 'Periodicity' button to change the period time of the system recording sensor data.

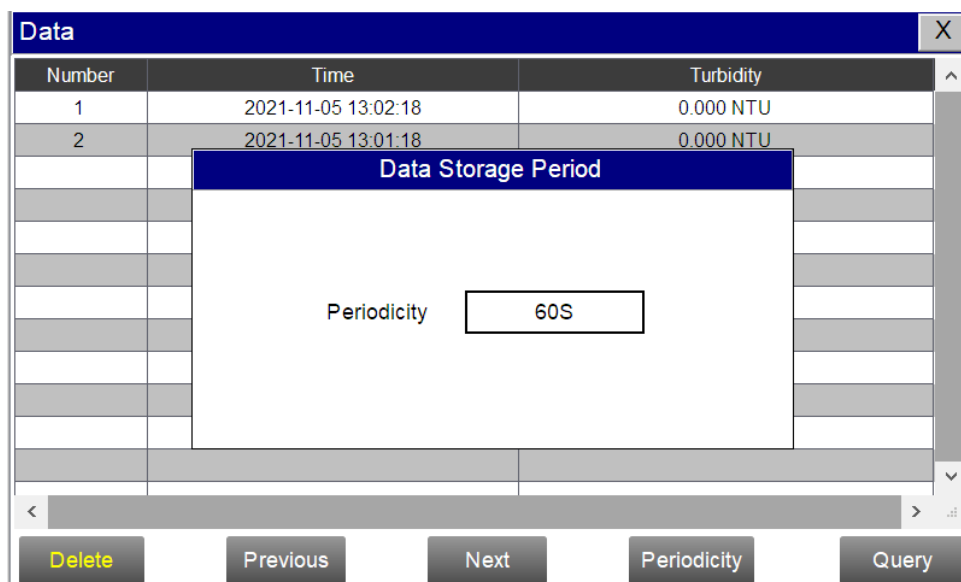

Figure 24 - Data Storage Period Time Setting

Click Delete in the lower left corner. After entering the retention time, click the Delete button to clear all historical data except the retention time.

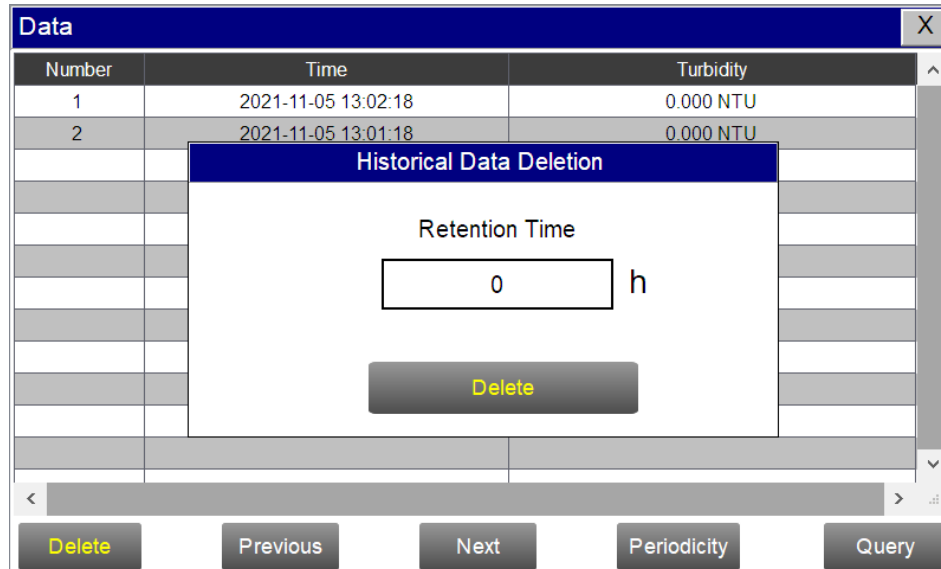

Figure 25 - Delete Historical Data

Click the query in the lower right corner, enter the start time and end time, and then click the query button. The data report will only display the historical data of the regional time. ***NOTE*** The start time and end time need to be filled in completely according to the system time format (note the time symbol format, which needs to be entered in the English) otherwise it will not be recognized for query.

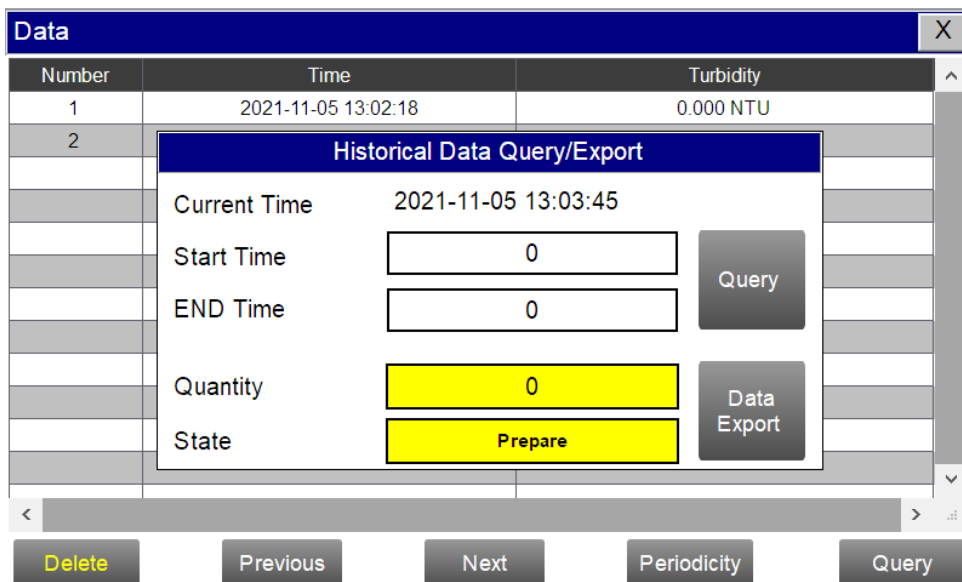

Figure 26 - Historical Data Query Export Interface

Exporting Historical Data

Insert the USB disk behind the screen and enter the time range of the data to be exported in the query area. Click on the data export tab, when the status is displayed as success and the quantity is a positive number, it means that the data export has been successful. If the status is displayed successfully, but the quantity is negative, this indicates that the data was not successfully exported, please check whether the time format is correct.

5.9. Historical Data Curve

Click the "Historical Curve" button in the menu bar to enter the trend curve interface. The ordinate (Y-Axis) is the monitoring value of the sensor and the abscissa (X-Axis) is the monitoring time. You can click the button below the abscissa to browse and view the values in different time periods. Clicking the Y-axis range will pop up the Y-axis range as shown in Figure 28. Enter the minimum and maximum values to change the displayed value of the Y-axis of the curve.

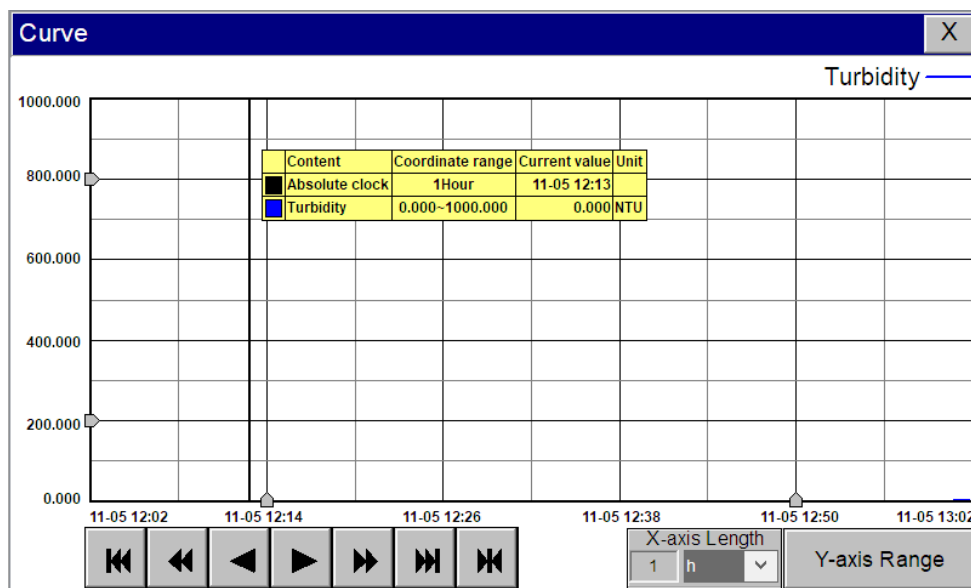

Figure 27 - Historical Curve Interface

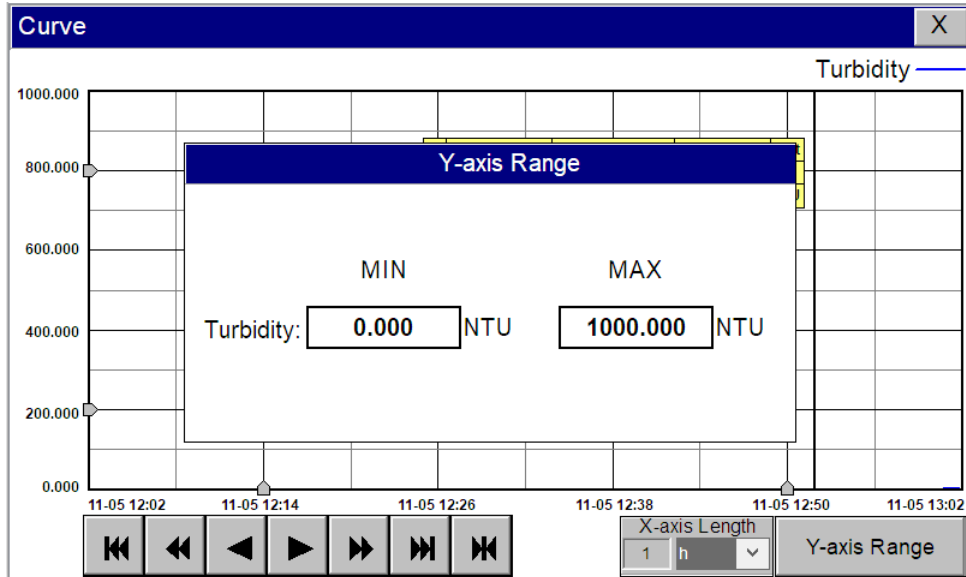

Figure 28 - Y-Axis range setting

- The curve will scroll back (to the left of the X-axis) one page
- The curve will scroll back (to the left of the X-axis) half the page of the curve
- The curve will scroll backward (to the left of the X-axis) to a position where the main line is drawn
- The curve will scroll forward (to the right of the X-axis) to a position where the main line is drawn
- The curve will scroll forward (to the right of the X-axis) half the page of the curve
- The curve will scroll forward (to the right of the X-axis) one page
- A dialog box will pop up to reset the starting time of the curve

Figure 29 - Button Introduction

Figure 30 - Time Setting Interface

5.10. User Management

Click the "User Management" button on the menu bar, and then you can choose "Login", "Logout" and "Administration" operations. Logout allows the the user log out of the interface and results VIEW ONLY of the real-time data reading, but cannot perform parameter settings and other operations. Click "Admin" to enter the user management interface, where you can add users, modify passwords and other operations. Users can set their own user name and password, and select the user group to which they belong. Among them, only users in the administrator group can set parameters such as calibration.

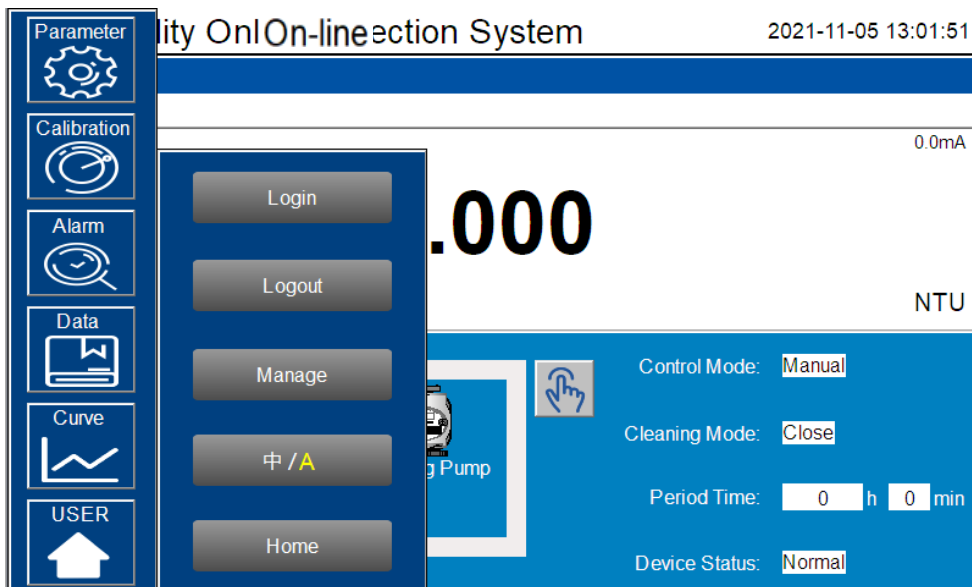

Figure 31 - User Management

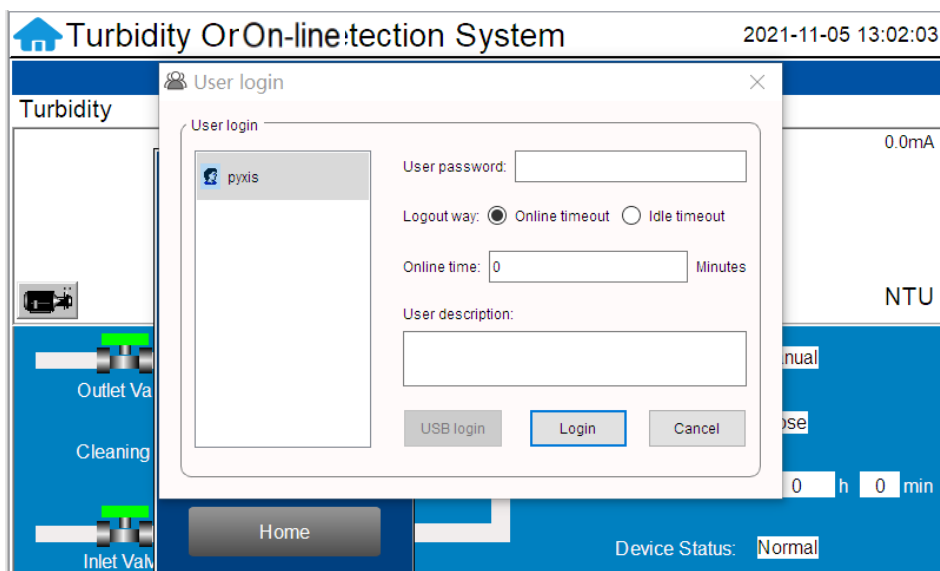

Figure 32 - User Management Interface

Change Password: Select the user to be changed, then click the “Change User” button, enter the user's own password in the User Password column and Confirm Password column, and click Confirm to modify successfully. ***NOTE*** - If the user does not want to set a password, the password can be deleted and saved.

6. Routine Maintenance

6.1. Mailing Address

No.	Define	Address	Format	Model	Unit	Note
1	Turbidity <i>(sensor for example only)</i>	1	Float	Read-only	NTU	Data format ABCD
2	Abnormal Communication of Sensor	3	uint	Read-only		0: Normal 1: Alarm
3	Sensor Upper Limit Alarm	4	uint	Read-only		0: Normal 1: Alarm
4	Sensor Lower Limit Alarm	5	uint	Read-only		0: Normal 1: Alarm
5	PLC Communication is Abnormal	6	uint	Read-only		0: Normal 1: Alarm
Communication Protocol: Standard Modbus-RTU						
Communication parameters: baud rate-9200, data bit-8, stop bit-1, parity bit-even						
Station number: 100						

7. Contact Us

Contact us if you have questions about the use or maintenance of the SP-350P Water Multimenter:

Pyxis Lab, Inc.

1729 Majestic Dr. Suite 5

Lafayette, CO 80026 USA

1-866-203-8397 www.pyxis-lab.com service@pyxis-lab.com