



LT-73X Series Ultra-Low Turbidity Sensors & Accessories

Ultra-Low Turbidity Sensors for Drinking/Clean Water Applications



Pyxis Lab® Inc.
21242 Spell Circle
Tomball, TX 77375
www.pyxis-lab.com

USER MANUAL

Table of Contents

1	Introduction.....	3
1.1	Main Features.....	3
2	Specifications.....	4
3	Unpacking Instrument.....	6
3.1	Standard Accessories Included	6
3.2	Optional Accessories	6
4	Installation	7
4.1	FR-100 Flow Reservoir Assembly for Drinking Water Installation	7
4.2	FT-100 Inline Tee Assembly Installation	10
4.3	Wiring.....	11
4.4	Connecting via Bluetooth	12
5	Setup and Calibration with uPyxis® Mobile App.....	12
5.1	Download uPyxis® Mobile App.....	12
5.2	Connecting to uPyxis® Mobile App.....	13
5.3	Calibration Screen and Reading	14
5.3.1	<i>Low Range Calibration</i>	15
5.3.2	<i>Mid Range Calibration</i>	15
5.3.3	<i>High Range Calibration</i>	16
5.3.4	<i>L -CAL Portable Calibration Kit Overview & Procedure Images</i>	16
5.4	Diagnosis Screen.....	18
5.5	Device Info Screen	19
6	Setup and Calibration with uPyxis® Desktop App.....	20
6.1	Install uPyxis® Desktop App.....	20
6.2	Connecting to uPyxis® Desktop App via Bluetooth.....	20
6.3	Connecting to uPyxis® Desktop App via USB-C Cable.....	22
6.4	Information Screen.....	23
6.5	Calibration Screen	24
6.5.1	<i>Low Range Calibration</i>	25
6.5.2	<i>Mid Range Calibration</i>	25
6.5.3	<i>High Range Calibration</i>	26
6.5.4	<i>L -CAL Portable Calibration Kit Overview & Procedure Images</i>	26
6.6	Diagnosis Screen.....	28
7	Outputs.....	28
7.1	4–20mA Output Setup.....	28
7.2	Adjusting the 4–20mA Span	29
7.3	Communication using Modbus RTU	30
8	Sensor Maintenance and Precaution	30
8.1	Methods to Cleaning the LT-73X Series Sensor	31
8.2	Storage	32
9	Troubleshooting.....	32
10	Contact Us.....	32

Warranty Information

Confidentiality

The information contained in this manual may be confidential and proprietary and is the property of Pyxis Lab, Inc. Information disclosed herein shall not be used to manufacture, construct, or otherwise reproduce the goods described. Information disclosed herein shall not be disclosed to others or made public in any manner without the express written consent of Pyxis Lab, Inc.

Standard Limited Warranty

Pyxis Lab warrants its products for defects in materials and workmanship. Pyxis Lab will, at its option, repair or replace instrument components that prove to be defective with new or remanufactured components (i.e., equivalent to new). The warranty set forth is exclusive and no other warranty, whether written or oral, is expressed or implied.

Warranty Term

The Pyxis warranty term is thirteen (13) months ex-works. In no event shall the standard limited warranty coverage extend beyond thirteen (13) months from original shipment date.

Warranty Service

Damaged or dysfunctional instruments may be returned to Pyxis for repair or replacement. In some instances, replacement instruments may be available for short duration loan or lease.

Pyxis warrants that any labor services provided shall conform to the reasonable standards of technical competency and performance effective at the time of delivery. All service interventions are to be reviewed and authorized as correct and complete at the completion of the service by a customer representative, or designate. Pyxis warrants these services for 30 days after the authorization and will correct any qualifying deficiency in labor provided that the labor service deficiency is exactly related to the originating event. No other remedy, other than the provision of labor services, may be applicable.

Repair components (parts and materials), but not consumables, provided during a repair, or purchased individually, are warranted for 90 days ex-works for materials and workmanship. In no event will the incorporation of a warranted repair component into an instrument extend the whole instrument's warranty beyond its original term.

Warranty Shipping

A Repair Authorization (RA) Number must be obtained from Pyxis Technical Support before any product can be returned to the factory. Pyxis will pay freight charges to ship replacement or repaired products to the customer. The customer shall pay freight charges for returning products to Pyxis. Any product returned to the factory without an RA number will be returned to the customer. To receive an RMA you can generate a request on our website at <https://pyxis-lab.com/request-tech-support/>.

Pyxis Technical Support

Contact Pyxis Technical Support at +1 (866) 203-8397, service@pyxis-lab.com, or by filling out a request for support at <https://pyxis-lab.com/request-tech-support/>.

1 Introduction

The LT-73X Series sensor is an inline turbidity sensor offered in the ranges of 0.001 to 1,000 NTU with an ultra-fine resolution and meeting ISO-7027 (850 nm LED) and EPA-180.1 (warm white LED) compliance guidelines. The quartz plate front surface in the LT-73X Series sensor allows for extended cleanliness and easy maintenance. This sensor is designed for optimal precision and performance in a wide range of turbidity using a 90° surface scatter configuration. The sensor can be installed in two flow assembly formats (**FR-100 Flow Reservoir Assembly** or **FT-100 Inline Tee Assembly**), making it versatile for a variety of drinking or industrial water applications. It is powered by a 24 VDC/1.5 W power supply and provides both 4–20 mA and RS-485 Modbus output signals. When clean, the unique Pyxis sensor design offers a stability of <0.02 NTU for up to one year without calibration. Additionally, this sensor can be wirelessly accessed via MA-CR Bluetooth adapter for Diagnostics, Cleaning, and Calibration when using the **uPyxis®** Mobile or Desktop App.

1.1 Main Features

The LT-73X Series sensor includes the following features:

- Warm white (3200 K) or Infrared (850 nm) LED for long operational life
- Resolution as low as 0.001 NTU
- FR-100 Flow Reservoir Assembly available for all LT-73X Series sensors for optimum resolution.
- FT-100 Inline Tee Assembly available for all LT-73X Series sensors for industrial applications.
- Built-in transmitter, without preamplifier or meter head.
- Combination 4–20mA isolated signal and RS-485 Modbus output
- Wireless calibration using the MA-CR Bluetooth/USB Adapter and **uPyxis®** Mobile or Desktop App
- Easily removed and cleaned without the need for tools.
- Optional Motorized Brush Clean Assembly (FRP-100 and FT-100-PLUS) purchased separately for automatic sensor eye cleaning. Contact order@pyxis-lab.com for details.
- Easy calibration with L-CAL portable Formazine calibration kit

2 Specifications

Table 1. LT-73X Series Specifications

Specification*	LT-736	LT-737	LT-739
Part Number (P/N)	53215	53216	53221
Turbidity Range	0.002–1000.00	0.001–5.000	0.001–40.00
Accuracy Using FR-100	<40 NTU: ± 0.005 NTU or $\pm 2\%$ >40 NTU: ± 0.02 NTU or $\pm 2\%$	± 0.005 NTU or $\pm 1\%$	<10 NTU: ± 0.005 NTU or $\pm 2\%$ >10 NTU: ± 0.01 NTU or $\pm 2\%$
Accuracy Using FT-100	<40 NTU: ± 0.01 NTU or $\pm 2\%$ >40 NTU: ± 0.05 NTU or $\pm 2\%$	± 0.01 NTU or $\pm 1\%$	<10 NTU: ± 0.01 NTU or $\pm 2\%$ >10 NTU: ± 0.02 NTU or $\pm 2\%$
Resolution Using FR-100	<40 NTU: ± 0.001 NTU or $\pm 1\%$ >40 NTU: ± 0.02 NTU or $\pm 1\%$	± 0.001 NTU or $\pm 1\%$	<10 NTU: ± 0.001 NTU or $\pm 1\%$ >10 NTU: ± 0.01 NTU or $\pm 1\%$
Resolution Using FT-100	<40 NTU: ± 0.002 NTU or $\pm 1\%$ >40 NTU: ± 0.05 NTU or $\pm 1\%$	± 0.002 NTU or $\pm 1\%$	<10 NTU: ± 0.002 NTU or $\pm 1\%$ >10 NTU: ± 0.02 NTU or $\pm 1\%$
Light Source (LED)	Warm White		
Compliance	EPA 180.1		
Calibration	Pyxis Formazine Standards with L-CAL for Field Cal = 0.01 Repeatability, Pyxis Lab Factory Ultra-Pure Calibration Services = 0.001 Repeatability		
Calibration Stability†	<0.02 NTU/year drift	<0.01 NTU/year drift	<0.02 NTU/year drift
Outputs	4–20mA Analog Output, RS-485 Digital Output with Modbus protocol		
Installation	FR-100 Flow Reservoir Assembly: ¼-inch OD Tubing, (Sold Separately) FT-100 Inline Tee Assembly: 1.5-inch NPT Thread & Socket (Sold Separately)		
Cables Included	Standard MA-4.9CR Cable (8-Pin Extension – 4.9 ft), Flying Lead MA-1.5CR Cable (8-Pin Male Adapter/Flying Leads – 1.5 m)		
Power Supply	22–26 VDC, 1.5 W		
Dimension (L x Dia)	7.4 x 1.44 inch (189 x 36 mm)		
Material	304 Stainless Steel		
Operational Temperature	33.8–131°F (1–50 °C)		
Operational Pressure	LT-73X Series sensors: up to 100 psi (6.9 Bar), FR-100 Flow Reservoir: atmospheric pressure, FT-100 Inline Tee: up to 100 psi (6.9 Bar)		
Operational Flow Rate	LT-73X Series sensors: 0–40 L/min (0–10.6 GPM), FR-100 Flow Reservoir: 200–1,800 mL/min, FT-100 Inline Tee: 0–40 L/min (0–10.6 GPM)		
Enclosure Rating	IP67		
Regulation	CE, RoHS, UKCA		

* With Pyxis's continuous improvement policy, these specifications are subject to change without notice.

† Assuming sensor is clean

Table 2. LT-73XB Specifications

Specification*	LT-736B	LT-737B	LT-739B
Part Number (P/N)	53223	53224	53225
Turbidity Range	0.002–1000.00	0.001–5.000	0.001–40.00
Accuracy Using FR-100	<40 NTU: ± 0.005 NTU or $\pm 2\%$ >40 NTU: ± 0.02 NTU or $\pm 2\%$	± 0.005 NTU or $\pm 1\%$	<10 NTU: ± 0.005 NTU or $\pm 2\%$ >10 NTU: ± 0.01 NTU or $\pm 2\%$
Accuracy Using FT-100	<40 NTU: ± 0.01 NTU or $\pm 2\%$ >40 NTU: ± 0.05 NTU or $\pm 2\%$	± 0.01 NTU or $\pm 1\%$	<10 NTU: ± 0.01 NTU or $\pm 2\%$ >10 NTU: ± 0.02 NTU or $\pm 2\%$
Resolution Using FR-100	<40 NTU: ± 0.001 NTU or $\pm 1\%$ >40 NTU: ± 0.02 NTU or $\pm 1\%$	± 0.001 NTU or $\pm 1\%$	<10 NTU: ± 0.001 NTU or $\pm 1\%$ >10 NTU: ± 0.01 NTU or $\pm 1\%$
Resolution Using FT-100	<40 NTU: ± 0.002 NTU or $\pm 1\%$ >40 NTU: ± 0.05 NTU or $\pm 1\%$	± 0.002 NTU or $\pm 1\%$	<10 NTU: ± 0.002 NTU or $\pm 1\%$ >10 NTU: ± 0.02 NTU or $\pm 1\%$
Light Source (LED)	850 nm		
Compliance	ISO-7027		
Calibration	Pyxis Formazine Standards with L-CAL for Field Cal = 0.01 Repeatability, Pyxis Lab Factory Ultra-Pure Calibration Services = 0.001 Repeatability		
Calibration Stability †	<0.02 NTU/year drift	<0.01 NTU/year drift	<0.02 NTU/year drift
Outputs	4–20mA Analog Output, RS-485 Digital Output with Modbus protocol		
Installation	FR-100 Flow Reservoir Assembly: ¼-inch OD Tubing, (Sold Separately) FT-100 Inline Tee Assembly: 1.5-inch NPT Thread & Socket (Sold Separately)		
Cables Included	Standard MA-4.9CR Cable (8-Pin Extension – 4.9 ft), Flying Lead MA-1.5CR Cable (8-Pin Male Adapter/Flying Leads – 1.5 m)		
Power Supply	22–26 VDC, 1.5 W		
Dimension (L × Dia)	7.4 × 1.44 inch (189 × 36 mm)		
Material	304 Stainless Steel		
Operational Temperature	33.8–131°F (1–50 °C)		
Operational Pressure	LT-73X Series sensors: up to 100 psi (6.9 Bar), FR-100 Flow Reservoir: atmospheric pressure, FT-100 Inline Tee: up to 100 psi (6.9 Bar)		
Operational Flow Rate	LT-73X Series sensors: 0–40 L/min (0–10.6 GPM), FR-100 Flow Reservoir: 200–1,800 mL/min, FT-100 Inline Tee: 0–40 L/min (0–10.6 GPM)		
Enclosure Rating	IP67		
Regulation	CE, RoHS, UKCA		

* With Pyxis's continuous improvement policy, these specifications are subject to change without notice.

† Assuming sensor is clean

3 Unpacking Instrument

Remove the instrument and accessories from the shipping container and inspect each item for any damage that may have occurred during shipping. Verify that all accessory items are included. If any item is missing or damaged, please contact Pyxis Lab Customer Service at service@pyxis-lab.com.

3.1 Standard Accessories Included

- MA-4.9CR Cable (4.9 ft 8-Pin Male/Female Extension Cable) P/N: 50745
- MA-1.5CR Cable (1.5 m/4.9 ft 8-Pin Male Adapter/Flying Lead) P/N: 50746
- User Manual available online at [Support Documents - Pyxis Lab, Inc. \(pyxis-lab.com\)](https://pyxis-lab.com/support)

3.2 Optional Accessories

The following optional accessories can be ordered at order@pyxis-lab.com or the Pyxis E-Store at <https://pyxis-lab.com/shop/>

Table 3. Optional Accessories

Accessory Name	Part Number (P/N)
FR-100 Flow Reservoir Assembly	50779
FT-100 Inline Tee Assembly	50780
MA-CR Bluetooth Adapter For Pyxis 8-Pin Sensors	MA-CR
MA-NEB USB Bluetooth Adapter For uPyxis ® Desktop	MA-NEB
PowerPACK-1 110VAC Outlet Powered Bluetooth Adapter	MA-BLE-1
MA-50CR Cable (15 m/50 ft 8-Pin Male/Female Extension Cable)	50743
L-CAL Portable Liquid Formazine Calibration Kit	53247
Formazine 2.0 NTU Turbidity Calibration Standard — 4,000 mL	57010-2L
Formazine 5.0 NTU Turbidity Calibration Standard — 4,000 mL	57010-5L
Formazine 10 NTU Turbidity Calibration Standard — 4,000 mL	57010-10L
Formazine 30 NTU Turbidity Calibration Standard — 4,000 mL	57010-30L
Formazine 200 NTU Turbidity Calibration Standard — 4,000 mL	57010-200L
Formazine 500 NTU Turbidity Calibration Standard — 4,000 mL	57010-500L

4 Installation

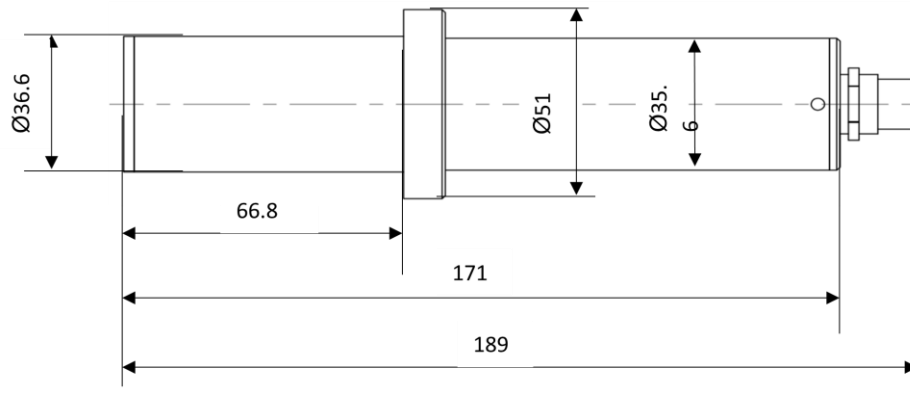

Figure 1. Dimension of the LT-73X Series sensor (mm)

4.1 FR-100 Flow Reservoir Assembly for Drinking Water Installation



Figure 2. LT-73X Series Sensor with FR-100 Flow Reservoir Assembly

For use in drinking water installations, the LT-73X Series ultra-low turbidity sensors should be installed using the Pyxis FR-100 Flow Reservoir Assembly. This uniquely designed reservoir operates in a by-pass format at a 200–1,800 mL/min flow rate and serves as a calming vessel. Specifically designed to reduce stray light interference, the FR-100 Flow Reservoir Assembly also allows for the elimination of air bubble entrainment, drop-out of large particulate and suspended solids including precipitated inorganics such as iron and manganese. The FR-100 Flow Reservoir Assembly comes wall- or panel-mountable and complete including ¼-inch tubing inlet with isolation valve, pressure reducing valve, inline rotameter, ⅜-inch tubing sample output and overflow assembly as well as ½-inch NPT bottom blowdown ball valve for solids removal. The LT-73X Series sensors can be easily installed via the union adapter provided onto the side wall of the FR-100 Flow Reservoir Assembly. Replacement sensors or reservoirs may be purchased independently.

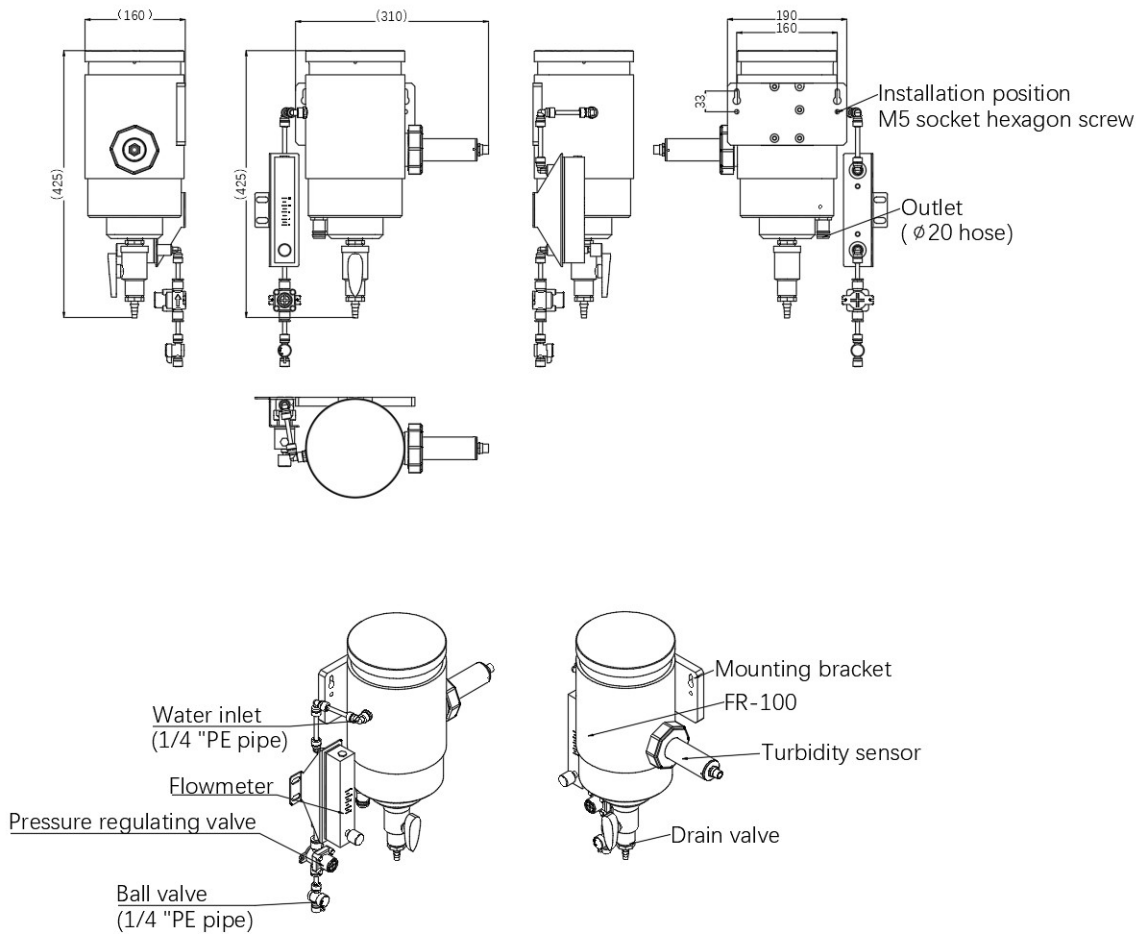

Figure 3. FR-100 Flow Reservoir Assembly Dimensions (mm) & Diagram



Figure 4. Top view of FR-100. Diffusers (6 each) are provided and can be randomly installed in overflow weir to help minimize air bubbles.

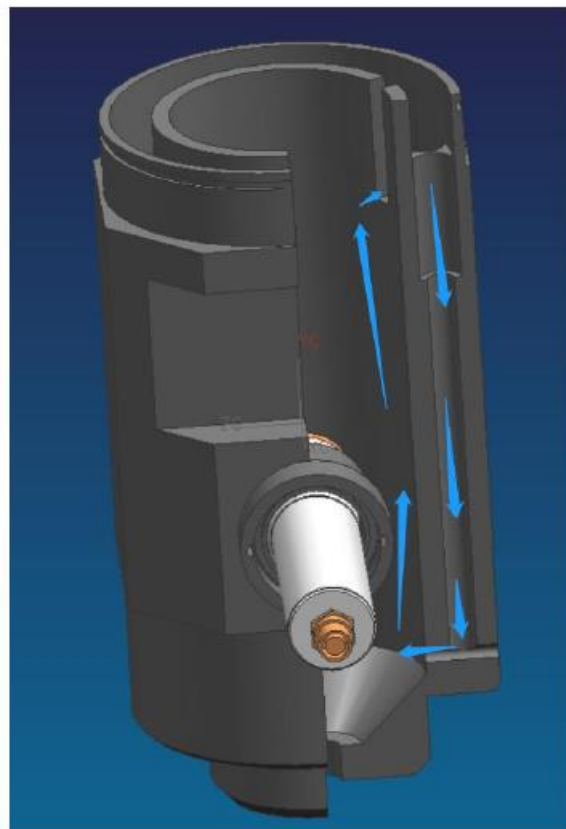
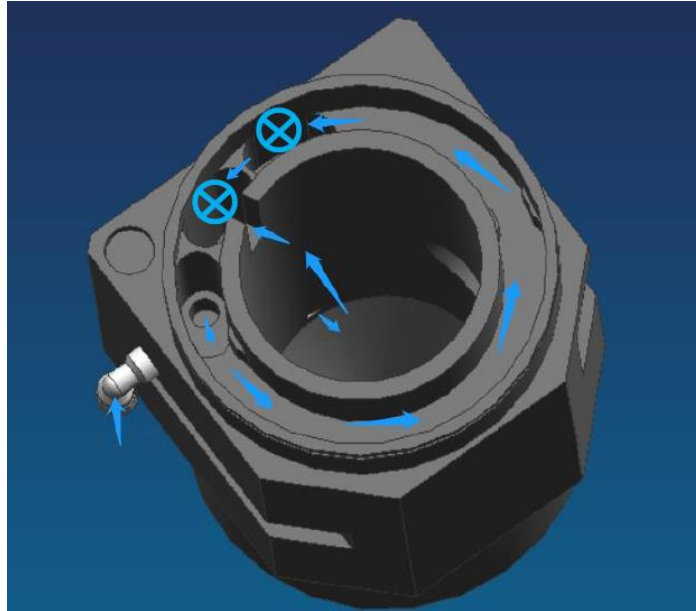

Figure 4A. FR-100 Sample Flow Path

4.2 FT-100 Inline Tee Assembly Installation



Figure 5. LT-73X Series Sensor with FT-100 Inline Tee Assembly

For use in alternative installations, the LT-73X Series ultra-low turbidity sensors may also be installed using the Pyxis FT-100 Inline Flow Tee Assembly. This uniquely designed in-line Tee operates at up to 40 Liters/Min (10.6 GPM) flow rate and operating pressures as high as 6.9 bar (100 psi). Constructed of Schedule 40-CPVC and designed with a unique 45° downward angle for extended sensor cleanliness, the FT-100 in-line Tee assembly allows for users to install the LT-73X Series sensor in pressurized flow applications with limited space. This inline tee dramatically reduces the installation space requirement and is highly compatible with most by-pass sensor plumbing installations, allowing the user to easily remove the sensor for wireless cleaning and maintenance. The LT-73X Series sensor’s flat distillate end is specifically designed to prevent air bubbles from accumulating when installed in the FT-100. When emptied and cleaned, the FT-100 may also serve as a low range (zero-point) calibration of the sensor via the **uPyxis®** App. The FT-100 Inline Flow Tee Assembly offers 1.5” FNPT threaded and socket adapters with quick unions to allow for rapid installation or replacement. The FT-100 Inline Flow Tee Assembly may be purchased independently as desired. ***NOTE*** In applications subject to significant air bubble entraining, Pyxis suggests installing the FT-100 with the Y-type tee and sensor pointing down. This installation method allows for the bubbles to be swept away from the sensor eye, eliminating interference.

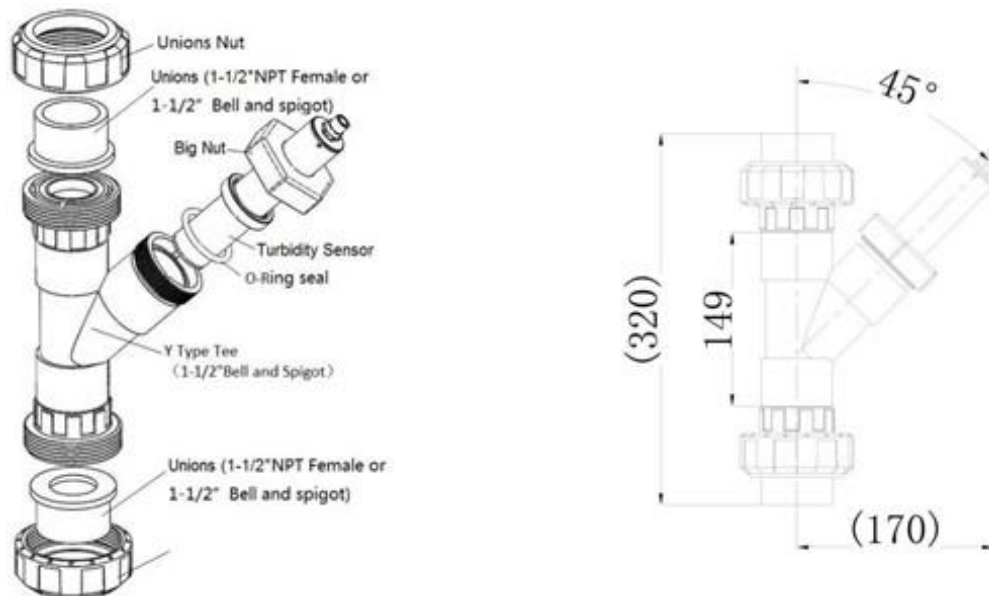

Figure 6. FT-100 Inline Tee Assembly Dimensions (mm) & Diagram

4.3 Wiring

If the power ground terminal and the negative 4–20mA terminal in the controller are internally connected (non-isolated 4–20mA input), it is unnecessary to connect the 4–20mA negative wire (gray) to the 4–20mA negative terminal in the controller. If a separate DC power supply other than that from the controller is used, make sure that the output from the power supply is rated for 22–26 VDC @ 65 mA.

NOTE *The negative 24V power terminal (power ground) and the negative 4–20mA terminal of the LT-73X Series sensor are internally connected.*

Follow the wiring table below to connect the LT-73X Series sensor to a controller:

Table 4.

Color	Designation
Red	24V
Brown	Power GND- and 4-20mA-
Gray*	4-20mA-
White	4-20mA + Turbidity
Pink	No Connect
Blue	RS-485 A
Yellow	RS-485 B
Green	Earth Ground – LT-737 and LT739 Series (458C – LT-736/LT-736B Only)

* Internally connected to the power ground

4.4 Connecting via Bluetooth

The Pyxis MA-CR Bluetooth/USB adapter (P/N: MA-CR) can be used to connect a LT-73X Series sensor to a smart phone with the **uPyxis®2.0** Mobile App or a computer with the **uPyxis®** Desktop App.

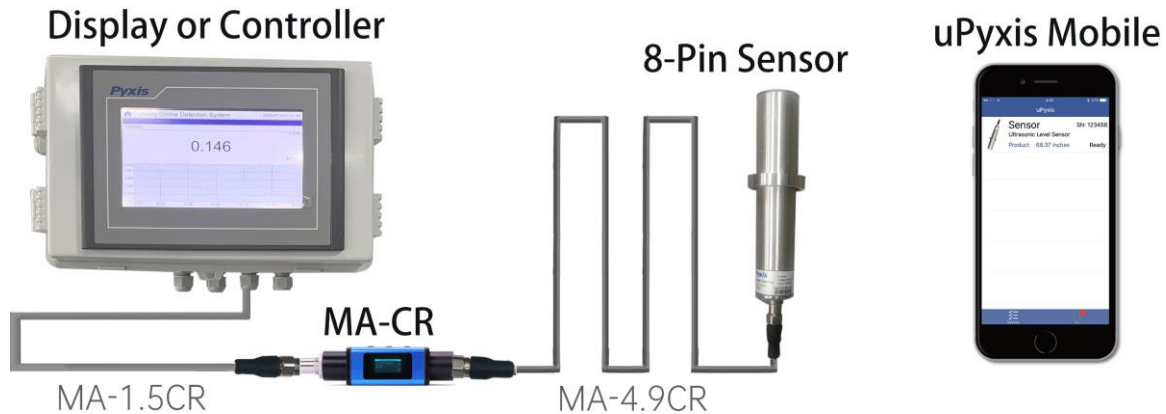

Figure 7. Bluetooth connection to LT-73X Series sensor with MA-CR and uPyxis Mobile App

5 Setup and Calibration with uPyxis® Mobile App

5.1 Download uPyxis® Mobile App

Download **uPyxis®** Mobile App from [Apple App Store](#) or [Google Play](#).



Figure 8. uPyxis® 2.0 Mobile App installation

5.2 Connecting to uPyxis® Mobile App

Connect the LT-73X Series sensor to a mobile smart phone according to the following steps:

1. Open **uPyxis®2.0** Mobile App.
2. On **uPyxis®2.0** Mobile App, pull down to refresh the list of available Pyxis devices.
3. If the connection is successful, the LT-73X Series and its Serial Number (SN) will be displayed (Figure 9).
4. Press on the **LT-73X Series sensor image**.

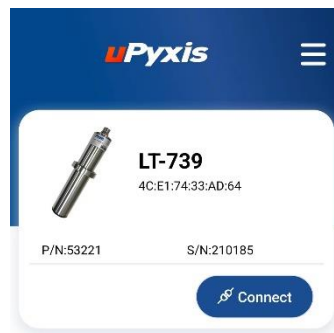

Figure 9.

5.3 Calibration Screen and Reading

When connected, the uPyxis®2.0 Mobile App will default to the **Calibration** screen. From the **Configuration** screen, you can perform calibrations by pressing on **Low Range Calibration**, **Mid Range Calibration**, **High Range Calibration**, and **4–20mA Span**. Please refer to the following table for the recommended Formazine turbidity standard solutions for each range:

Table 5. Recommended Formazine Calibration Standards

Calibration Range	LT-736/LT-736B	LT-737/LT-737B	LT-739/LT-739B
Near Zero/Low	Bubble-free DI or sample <0.1 NTU		
Mid	5–50 NTU	1–2 NTU	5–10 NTU
High	500–1000 NTU	3–5 NTU	20–40 NTU

NOTE Calibration of the LT-73X Series sensor should be conducted by using the L-CAL Portable Liquid Formazine Calibration Kit (P/N:53247). Please refer Section to 5.3.4 of this manual for details.

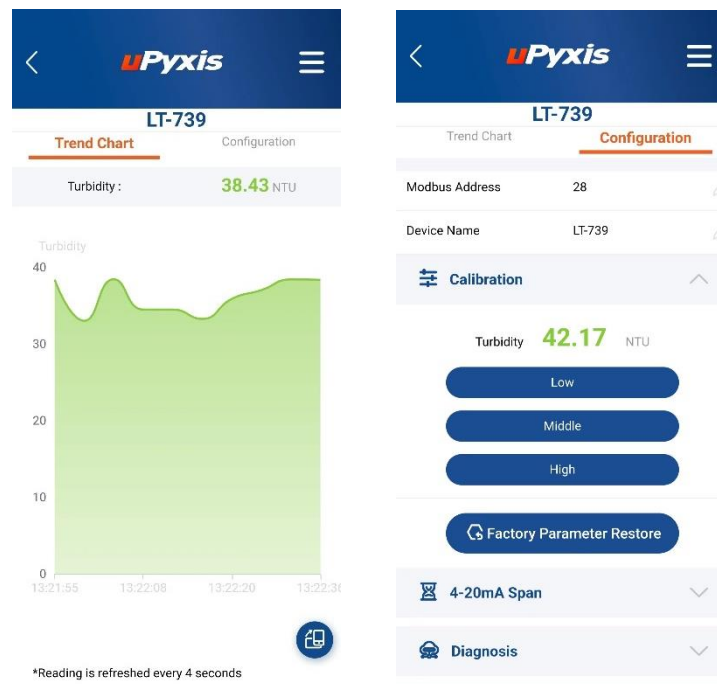

Figure 10.

5.3.1 Low Range Calibration

1. Isolate and empty the FR-100 Flow Reservoir or FT-100 Tee of sample water.
2. Remove the LT-73x Series sensor and gently wipe sensor eye surface with a dust- free cloth and confirm there are no obvious contaminants.
3. Rinse the L-CAL portable calibration kit with deionized (DI) water to ensure no contamination is present. Repeat up to three times to ensure optimum cleanliness.
4. Insert the LT-73x Series sensor into the L-CAL. Note the sensor stabilizing brace can be positioned under the sensor body to allow the L-CAL to remain level.
5. Fill the L-CAL with 250-500mL of bubble free deionized or distilled water and place the lid back onto the L-CAL to ensure a completely dark environment for the sensor.
6. Remove the vent tube cap from the L-CAL to allow any possible air bubbles to escape.
7. Allow the displayed data to stabilize; this could take some time to eliminate air bubbles.
8. Press **Low Range Calibration** to begin the low range calibration.
9. Enter "**0.05**" for the turbidity value of the DI water (Low Range Value).
**NOTE* Because there is no global standard for zero turbidity in the industry, Pyxis recommends 0.05 NTU as a target low range calibration using bubble-free DI water. Users may vary from this entry value if desired, however, a true "zero" turbidity calibration standard does not exist.*
10. If the calibration is successful, the interface will return a message of "Calibration Success". If the calibration has failed, the interface will return a message of "Calibration Failed" and the user must repeat the process.
11. Images for the L-CAL procedure images can be found in Section 5.3.4 of this manual.

5.3.2 Mid Range Calibration

1. Empty the L-CAL portable calibration kit completely and refill with 250-500mL of a known turbidity standard solution according to the **Recommended Formazine Calibration Standards** table based on the LT-73X series sensor being calibrated (see Section 5.3).
2. Place the lid back onto the L-CAL to ensure a completely dark environment for the sensor.
3. Remove the vent tube cap from the L-CAL to allow any possible air bubbles to escape.
4. Allow the displayed data to stabilize.
5. Press **Mid Range Calibration** to begin the middle range calibration.
6. Enter the known turbidity value of the calibration standard.
7. If the calibration is successful, the interface will return a message of "Calibration Success". If the calibration has failed, the interface will return a message of "Calibration Failed" and the user must repeat the process.
8. Images for the L-CAL procedure images can be found in Section 5.3.4 of this manual.

5.3.3 High Range Calibration

If the high range calibration is not required, the user does not need to calibrate the high range. To continue the high range calibration using a second turbidity standard solution, use the following steps:

NOTE *If the high range calibration is not required, the user does not need to calibrate the high range. An example of this may be if the sensor is being operated in the lower range of turbidity, then only a Low and Mid calibration are necessary. High range calibration is only necessary if the sensor is exposed to turbidity values exceeding the Mid Range level.*

1. Empty the L-CAL portable calibration kit completely and refill with 250-500mL of a known turbidity standard solution according to the **Recommended Formazine Calibration Standards** table based on the LT-73X series sensor being calibrated (see Section 5.3).
2. Place the lid back onto the L-CAL to ensure a completely dark environment for the sensor.
3. Remove the vent tube cap from the L-CAL to allow any possible air bubbles to escape.
4. Allow the displayed data to stabilize.
5. Press **High Range Calibration** to begin the middle range calibration.
6. Enter the known turbidity value of the calibration standard.
7. If the calibration is successful, the interface will return a message of "Calibration Success". If the calibration has failed, the interface will return a message of "Calibration Failed" and the user must repeat the process.
8. Images for the L-CAL procedure images can be found in Section 5.3.4 of this manual.

5.3.4 L-CAL Portable Calibration Kit Overview & Procedure Images

Pyxis Lab has developed a portable and reusable liquid-state turbidity calibration kit for rapid calibration of the Pyxis LT-73X Series inline ultra-low turbidity sensors. The LT-73X Series ultra-low turbidity sensors are factory calibrated using certified Formazine liquid standards. The L-CAL calibration kit allows users to calibrate all LT-73X Series ultra-low turbidity sensors using smaller volumes of Formazine turbidity calibration standards providing an affordable and reusable solution for long term sensor reliability. The unique design of the L-CAL liquid calibration kit allows the LT-73X sensor to be easily inserted and calibrated with the sensor in a horizontal position, allowing air bubbles to be evacuated through the integrated air-vent line ensuring superior accuracy of the sensor calibration. The L-CAL has an easy to remove lid allowing users to fill and empty the calibration kit with DI water for vessel/sensor cleaning and Formazine calibration standards for sensor calibration.



Figure 11.
L-CAL Liquid Turbidity Calibration Kit
(P/N 53247)

Insert LT-73X Sensor



Tighten Sensor Nut



Position Vertically and Remove Lid



Preclean by adding DI-Water (250-500mL)



Insert Lid



Gently Shake Then Empty Contents



Add Calibration Standard (250-500mL)



Insert Lid and Remove Air Bubble Vent Line Cap



PROCEED TO
CALIBRATING
SENSOR
Via
uPyxis APP

**NOTE* Sensor Brace Included with L-CAL Kit for Stability*



WATCH PROCEDURE VIDEO <https://www.youtube.com/watch?v=1MuJM5Q5VB4>

Turbidity Calibration Principals & Considerations

The precision, resolution and the low detection limit of the LT-73X Series sensors are not affected by the calibration method, regardless of using certified Formazine standards and the L-CAL kit. The calibration only affects the turbidity sensor accuracy. The nature of turbidity measurement makes an absolute turbidity value not easily obtainable for any sensor manufacturer although proper standards and methods are followed. For example, turbidity values greater than 1.0 NTU measured on real-world samples with different sensors, even from the single manufacturer, could differ significantly. For ultra-low turbidity (less than 0.3 NTU) measurement using the same methods (ISO-7027 or EPA-180.1), it is likely that the values from different sensors can agree within 0.05 NTU. As such, the user should choose a calibration method and remain with the same calibration method for consistency.

5.4 Diagnosis Screen

From the **Diagnosis** screen, you can check the diagnosis condition as well as **Export & Upload**. This feature may be used for technical support when communicating with service@pyxis-lab.com.

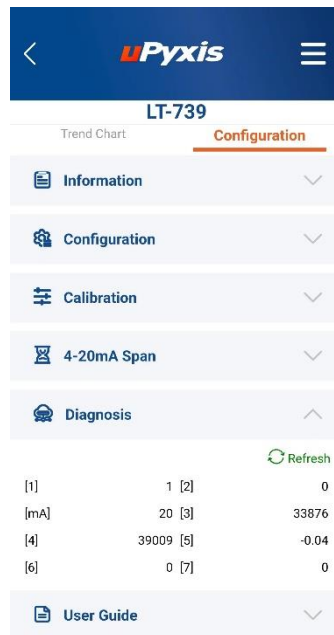

Figure 12.

5.5 Device Info Screen

From the **Device Info** screen. You can name the Device or Product.

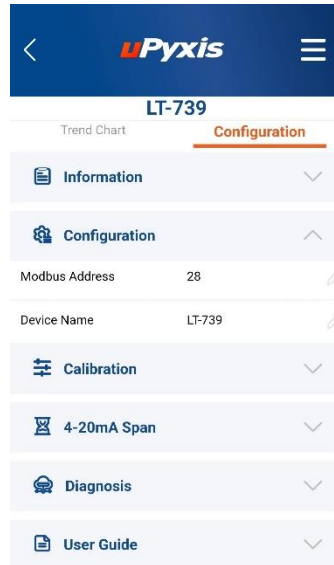

Figure 13.

6 Setup and Calibration with uPyxis® Desktop App

6.1 Install uPyxis® Desktop App

Download and install uPyxis Desktop APP on your PC or Laptop from <https://upyxis.pyxis-lab.com.cn/release/pc/uPyxis.Setup-latest.zip>

Click **Install** to start the installation process. Follow the screen instructions to complete the USB driver and uPyxis® installation.

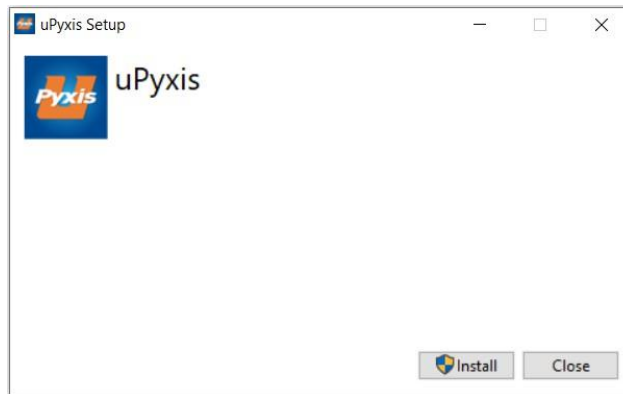

Figure 14. uPyxis® Desktop App installation

6.2 Connecting to uPyxis® Desktop App via Bluetooth

A Bluetooth adapter (P/N: MA-CR) can be used to connect a LT-73X Series sensor to a laptop or a desktop computer with a Bluetooth/USB Adapter (P/N: MA-NEB) and the uPyxis® Desktop App. The power should be sourced from a 24VDC power terminal of a controller. If a controller is not available, please purchase a Pyxis **PowerPACK Series** auxiliary power supply with Bluetooth (see Section 3.2), or an alternative 24VDC power supply that can directly connect to the LT-73X Series sensor with proper cable connectors from Pyxis.

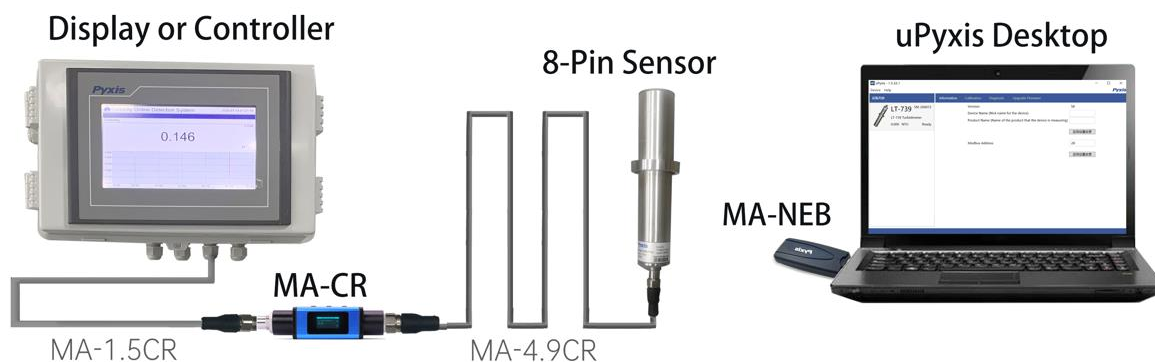

Figure 15. Bluetooth connection to LT-73X Series sensor with MA-CR, MA-NEB and uPyxis Desktop App.

Connect the LT-73X Series sensor to a Windows computer using a Bluetooth/USB adapter (P/N: MA-NEB) according to the following steps:

1. Install the MA-CR Bluetooth Adapter on the 8Pin output cable from the LT-73X series as outlined on page 19 as seen in **Figure 15** (if powered by a controller).
2. Plug the MA-NEB Bluetooth/USB adapter into a USB port of the PC.
3. Launch the **uPyxis®** Desktop App on the PC.
4. On **uPyxis®** Desktop App, click Device → **Connect via USB-Bluetooth** (Figure 15).
5. If the connection is successful, the LT-73X sensor and its Serial Number (S/N) will be displayed in the left pane of the **uPyxis®** window. ***NOTE*** After the sensor and Bluetooth are powered up, it may take up to 10 seconds for the adapter to establish the wireless signal for communication.

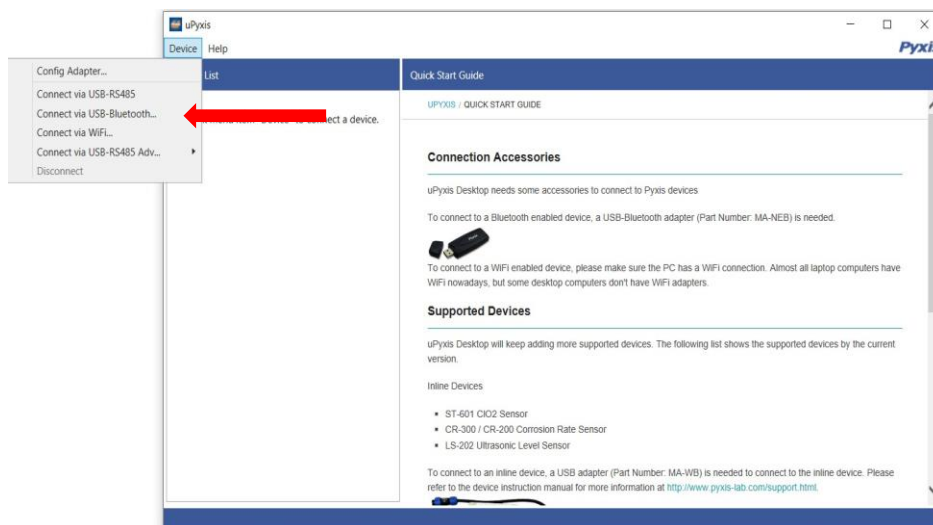

Figure 16.

6.3 Connecting to uPyxis® Desktop App via USB-C Cable

For those desiring not to use wireless connection to uPyxis, the MA-CR Bluetooth adapter (P/N: MA-CR) can be used to connect a LT-73X Series sensor to a laptop or a desktop computer with a USB-C cable and the **uPyxis® Desktop App**.

- 1) Download and install uPyxis Desktop APP from <https://upyxis.pyxis-lab.com.cn/release/pc/uPyxis.Setup-latest.zip>
- 2) Connect a USB Type-C cable to the port at the bottom of the MA-CR and to the USB port of the laptop or computer. This will provide power to the MA-CR from the laptop/computer. Connect the MA-CR to the ST-500W sensor. The MA-CR Bluetooth adapter will boost the 5V of the regular USB to 24V to power the sensor for use with uPyxis Desktop App.



MA-CR Bluetooth Adapter – Bottom USB-C

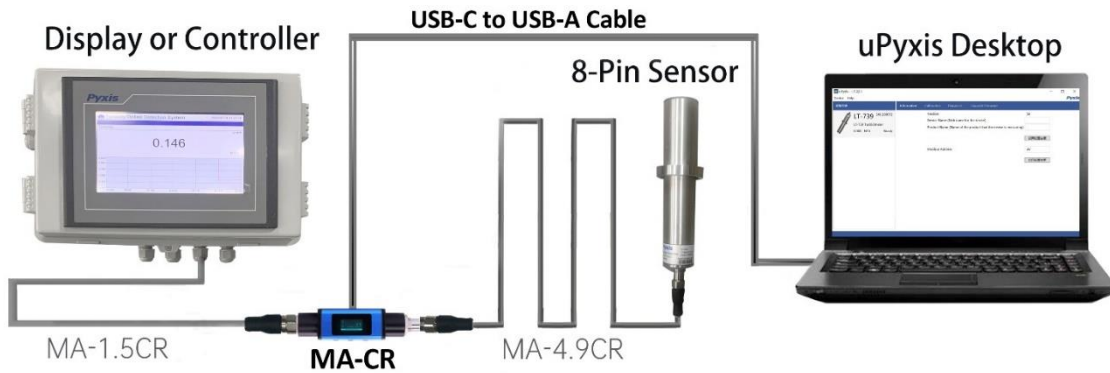

Figure 17.

- 3) Set the MA-CR to operate in USB Mode by following the steps below.
 - a. Once the MA-CR screen is powered Press ◀ or ▶ until you arrive at (USB to RS485) screen.
 - b. Press the **OK** Button.
 - c. Follow Prompts below to Enable USB feature. Once enabled, you may connect to uPyxis.



- 4) Open the desktop uPyxis APP.
- 5) Click Device to launch the connection option menu.
- 6) Select Connect via USB-RS485 (Figure 18).
- 7) Select the Comm Port to make a connection. Normally only one Comm port is identified by uPyxis. If more than one Comm port listed in the selection dropdown, you may try to select each one to see if a connection can be made. Alternatively, you may use the Windows Device Manager to identify the Comm Port that the Pyxis USB adapter is using.

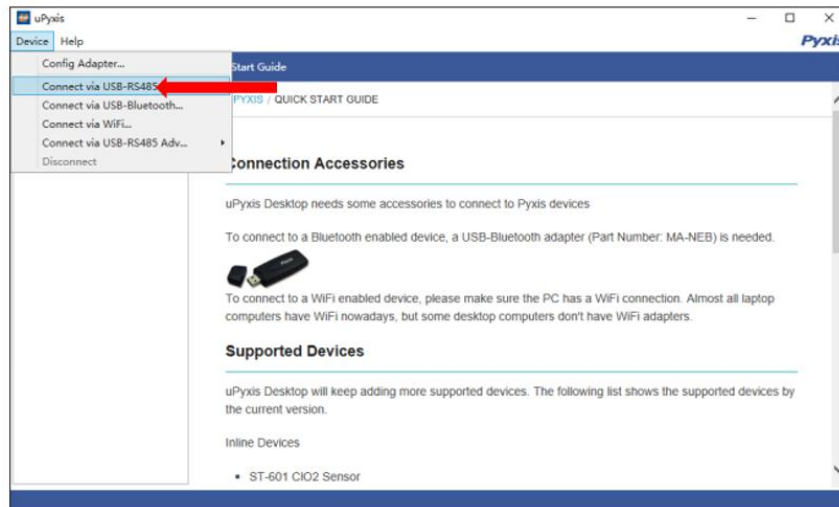

Figure 18. Connect to LT-73X Series via USB-RS485 Option

After the connection is established, the LT-73X serial number and current turbidity reading are displayed on the left of the information page (Figure 19). In this page, a nickname can be assigned to the probe. The probe Modbus address can be changed in this page.

6.4 Information Screen

Once connected to the device, a picture of the device will appear on the top-left corner of the window and the uPyxis® Desktop App will default to the **Information** screen. On the **Information** screen you can set the information description for **Device Name**, **Product Name**, and **Modbus Address**, then click **Apply Settings** to save.

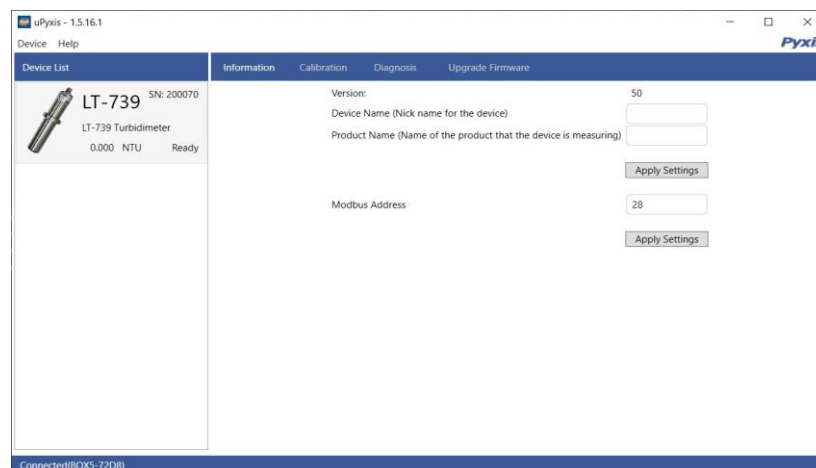

Figure 19.

6.5 Calibration Screen

To calibrate the device, click on **Calibration**. On the **Calibration** screen there are three calibration buttons, **Low Range Calibration**, **Mid Range Calibration**, **High Range Calibration**, and **4–20mA Span**. The screen also displays the reading of the device. The reading refresh rate is every 4 seconds. Please refer to the following table for the recommended turbidity standard solution for each range:

Table 6. Recommended Formazine Calibration Standards

Calibration Range	LT-736/LT-736B	LT-737/LT-737B	LT-739/LT-739B
Near Zero/Low	Bubble-free DI or sample <0.1 NTU		
Mid	5–50 NTU	1–2 NTU	5–10 NTU
High	500–1000 NTU	3–5 NTU	20–40 NTU

NOTE Calibration of the LT-73X Series sensor should be conducted by using the L-CAL Portable Liquid Formazine Calibration Kit (P/N:53247). Please refer to Section 6.5.4 of this manual for details.

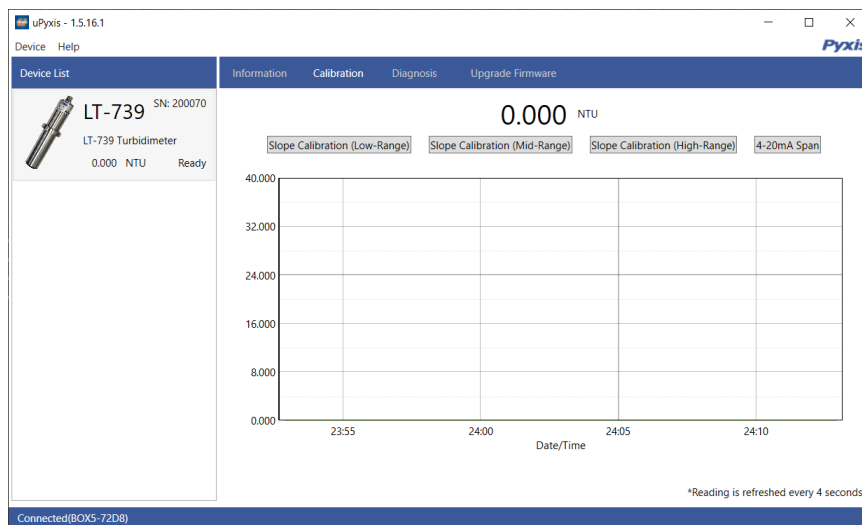

Figure 20.

6.5.1 Low Range Calibration

1. Isolate and empty the FR-100 Flow Reservoir or FT-100 Tee of sample water.
2. Remove the LT-73x Series sensor and gently wipe sensor eye surface with a dust- free cloth and confirm there are no obvious contaminants.
3. Rinse the L-CAL portable calibration kit with deionized (DI) water to ensure no contamination is present. Repeat up to three times to ensure optimum cleanliness.
4. Insert the LT-73x Series sensor into the L-CAL. Note the sensor stabilizing brace can be positioned under the sensor body to allow the L-CAL to remain level.
5. Fill the L-CAL with 250-500mL of bubble free deionized or distilled water and place the lid back onto the L-CAL to ensure a completely dark environment for the sensor.
6. Remove the vent tube cap from the L-CAL to allow any possible air bubbles to escape.
7. Allow the displayed data to stabilize; this could take some time to eliminate air bubbles.
8. Press **Low Range Calibration** to begin the low range calibration.
9. Enter "**0.05**" for the turbidity value of the DI water (Low Range Value).
**NOTE* Because there is no global standard for zero turbidity in the industry, Pyxis recommends 0.05 NTU as a target low range calibration using bubble-free DI water. Users may vary from this entry value if desired, however, a true "zero" turbidity calibration standard does not exist.*
10. If the calibration is successful, the interface will return a message of "Calibration Success". If the calibration has failed, the interface will return a message of "Calibration Failed" and the user must repeat the process.
11. Images for the L-CAL procedure images can be found in Section 6.5.4 of this manual.

6.5.2 Mid Range Calibration

1. Empty the L-CAL portable calibration kit completely and refill with 250-500mL of a known turbidity standard solution according to the **Recommended Formazine Calibration Standards** table based on the LT-73X series sensor being calibrated (see Section 6.5).
2. Place the lid back onto the L-CAL to ensure a completely dark environment for the sensor.
3. Remove the vent tube cap from the L-CAL to allow any possible air bubbles to escape.
4. Allow the displayed data to stabilize.
5. Press **Mid Range Calibration** to begin the middle range calibration.
6. Enter the known turbidity value of the calibration standard.
7. If the calibration is successful, the interface will return a message of "Calibration Success". If the calibration has failed, the interface will return a message of "Calibration Failed" and the user must repeat the process.
8. Images for the L-CAL procedure images can be found in Section 6.5.4 of this manual.

6.5.3 High Range Calibration

If the high range calibration is not required, the user does not need to calibrate the high range. To continue the high range calibration using a second turbidity standard solution, use the following steps:

NOTE *If the high range calibration is not required, the user does not need to calibrate the high range. An example of this may be if the sensor is being operated in the lower range of turbidity, then only a Low and Mid calibration are necessary. High range calibration is only necessary if the sensor is exposed to turbidity values exceeding the Mid Range level.*

1. Empty the L-CAL portable calibration kit completely and refill with 250-500mL of a known turbidity standard solution according to the **Recommended Formazine Calibration Standards** table based on the LT-73X series sensor being calibrated (see Section 5.3).
2. Place the lid back onto the L-CAL to ensure a completely dark environment for the sensor.
3. Remove the vent tube cap from the L-CAL to allow any possible air bubbles to escape.
4. Allow the displayed data to stabilize.
5. Press **High Range Calibration** to begin the middle range calibration.
6. Enter the known turbidity value of the calibration standard.
7. If the calibration is successful, the interface will return a message of "Calibration Success". If the calibration has failed, the interface will return a message of "Calibration Failed" and the user must repeat the process.
8. Images for the L-CAL procedure images can be found in Section 6.5.4 of this manual.

6.5.4 L-CAL Portable Calibration Kit Overview & Procedure Images

Pyxis Lab has developed a portable and reusable liquid-state turbidity calibration kit for rapid calibration of the Pyxis LT-73X Series inline ultra-low turbidity sensors. The LT-73X Series ultra-low turbidity sensors are factory calibrated using certified Formazine liquid standards. The L-CAL calibration kit allows users to calibrate all LT-73X Series ultra-low turbidity sensors using smaller volumes of Formazine turbidity calibration standards providing an affordable and reusable solution for long term sensor reliability. The unique design of the L-CAL liquid calibration kit allows the LT-73X sensor to be easily inserted and calibrated with the sensor in a horizontal position, allowing air bubbles to be evacuated through the integrated air-vent line ensuring superior accuracy of the sensor calibration. The L-CAL has an easy to remove lid allowing users to fill and empty the calibration kit with DI water for vessel/sensor cleaning and Formazine calibration standards for sensor calibration.



Figure 21.
L-CAL Liquid Turbidity Calibration Kit
(P/N 53247)

Insert LT-73X Sensor



Tighten Sensor Nut



Position Vertically and Remove Lid



Preclean by adding DI-Water (250-500mL)



Insert Lid



Gently Shake Then Empty Contents



Add Calibration Standard (250-500mL)



Insert Lid and Remove Air Bubble Vent Line Cap



**PROCEED TO
CALIBRATING
SENSOR
Via
uPyxis APP**

**NOTE* Sensor Brace Included with L-CAL Kit for Stability*

Turbidity Calibration Principals & Considerations

The precision, resolution and the low detection limit of the LT-73X Series sensors are not affected by the calibration method, regardless of using certified Formazine standards and the L-CAL kit. The calibration only affects the turbidity sensor accuracy. The nature of turbidity measurement makes an absolute turbidity value not easily obtainable for any sensor manufacturer although proper standards and methods are followed. For example, turbidity values greater than 1.0 NTU measured on real-world samples with different sensors, even from the single manufacturer, could differ significantly. For ultra-low turbidity (less than 0.3 NTU) measurement using the same methods (ISO-7027 or EPA-180.1), it is likely that the values from different sensors can agree within 0.05 NTU. As such, the user should choose a calibration method and remain with the same calibration method for consistency.

6.6 Diagnosis Screen

After the device has been calibrated and installation has been completed, to check diagnosis, click on **Diagnosis**. When in the **Diagnosis** screen you can view the Diagnosis Condition of the device. This feature may be used for technical support when communicating with service@pyxis-lab.com.

To perform a Cleanliness Check, first select the **Diagnosis Condition** which defines the fluid type that the LT-73X Series sensor is currently measuring, then click **Cleanliness Check**. If the sensor is clean, a green **Clean** message will be shown. If the sensor is severely fouled, a red **Dirty** message will be shown. In this case, follow the procedure in the **Methods to Cleaning the LT-73X Series Sensor** section of this manual.

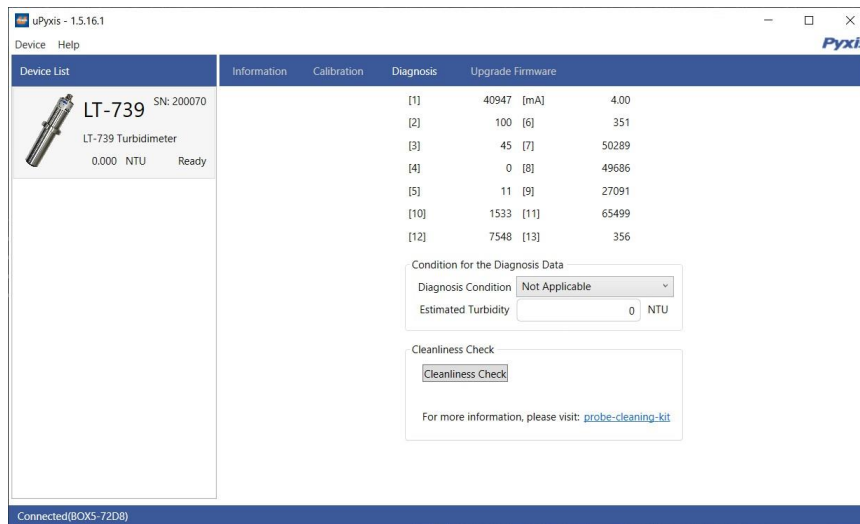

Figure 22.

7 Outputs

7.1 4–20mA Output Setup

Please refer to the 4-20mA scale values for each of the LT-73X Series sensors below. This information should be used for configuration of the connected controller, PLC or DCS when communicating in 4-20mA analog format from the LT-73X Series sensor.

Table 7. Factory 4-20mA Scales for LT-73X Series sensors.

Sensor Name	4mA Value	20mA Value
LT-736 / LT-736B	0 NTU	1,000 NTU
LT-737 / LT-737B	0 NTU	5.0 NTU
LT-739 / LT-739B	0 NTU	40.0 NTU

7.2 Adjusting the 4–20mA Span

Users may adjust the output scale using 4–20mA Span to alter the turbidity NTU value corresponding to the 20mA output via uPyxis®. For the uPyxis® Mobile App, press **4-20mA Span** found on the **Calibration and Reading Screen**, shown in Figure 23. For the uPyxis® Desktop App, click **4-20mA Span** found on the **Calibration Screen**, shown in Figure 24. ***NOTE*** the 20mA value may be adjusted only to an NTU value lower than the upper factory limit of the sensor.

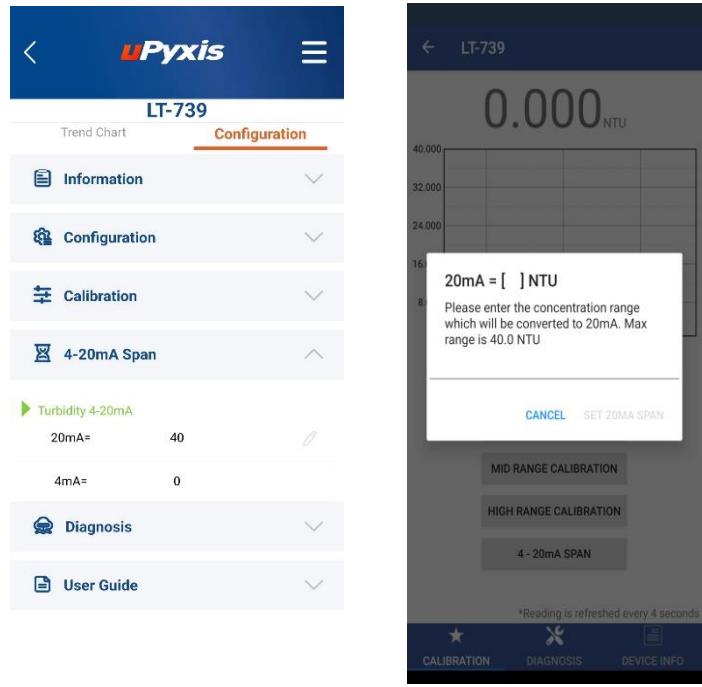

Figure 23.

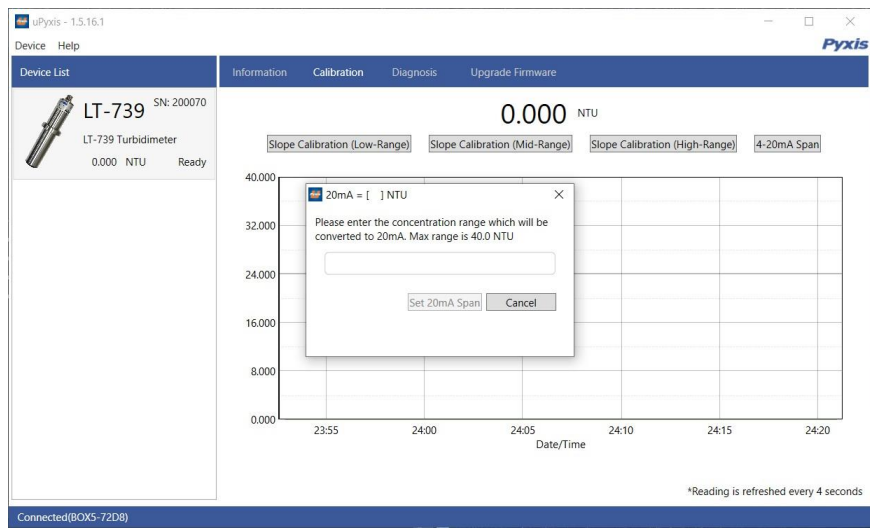

Figure 24.

7.3 Communication using Modbus RTU

The LT-73X Series sensor is configured as a Modbus slave device. In addition to the turbidity NTU value, many operational parameters, including warning and error messages, are available via a Modbus RTU connection. Contact Pyxis Lab Customer Service (service@pyxis-lab.com) for more information.

8 Sensor Maintenance and Precaution

The LT-73X Series sensor is designed to provide reliable and continuous turbidity readings even when installed in moderately contaminated industrial cooling waters. Although the optics are compensated for the effects of moderate fouling, heavy fouling will prevent the light from reaching the sensor, resulting in low readings and the potential for product overfeed if the LT-73X Series sensor is used as part of an automated control system. When used to control product dosing, it is suggested that the automation system be configured to provide backup to limit potential product overfeed, for example by limiting pump size or duration, or by alarming if the pumping rate exceeds a desired maximum limit.

The LT-73X Series sensor is designed to be easily removed, inspected, and cleaned if required. It is suggested that the LT-73X Series sensor be checked for fouling and cleaned/calibrated on a monthly basis. Heavily contaminated waters may require more frequent cleanings. Cleaner water sources with less contamination may not require cleaning for several months.

8.1 Methods to Cleaning the LT-73X Series Sensor

Any equipment in contact with industrial cooling systems is subject to many potential foulants and contaminants. Our inline sensor cleaning solutions below have been shown to remove most common foulants and contaminants. A small, soft bristle brush, Q-Tips cotton swab, or soft cloth may be used to safely clean the sensor housing and the quartz optical sensor channel. These components and more come with a Pyxis Lab **Inline Probe Cleaning Solution Kit** (P/N: SER-01) which can be purchased at our online E-Store <https://pyxis-lab.com/product/st-series-probe-cleaning-kit/>



Figure 25. Inline Probe Cleaning Solution Kit

To clean the LT-73X Series sensor, soak the lower half of the sensor in 100 mL inline sensor cleaning solution for 15 minutes. Rinse the LT-73X Series sensor with distilled water and check for a clean sensor eye. If the surface is not entirely clean, continue to soak the LT-73X Series sensor for an additional 15 minutes. Use the small, soft bristle brush and Q-Tips cotton swabs as necessary to remove any remaining contaminants on the LT-73X Series sensor eye.

8.2 Storage

Avoid long term storage at temperatures over 100 °F. In an outdoor installation, properly shield the LT-73X Series sensor from direct sunlight and precipitation.

9 Troubleshooting

If the LT-73X Series sensor output signal is not stable and fluctuates significantly, make an additional ground connection — connect the black (shield) wire to a conductor that contacts the sample water electrically such as a metal pipe adjacent to the LT-73X Series tee.

10 Contact Us

Pyxis Lab, Inc

21242 Spell Circle

Tomball, TX 77375 USA

www.pyxis-lab.com

Phone: +1 (866) 203-8397

Email: service@pyxis-lab.com