

## LT-635 TSS SENSOR

Self-Cleaning Submersible & Inline Total Suspended Solids Sensor

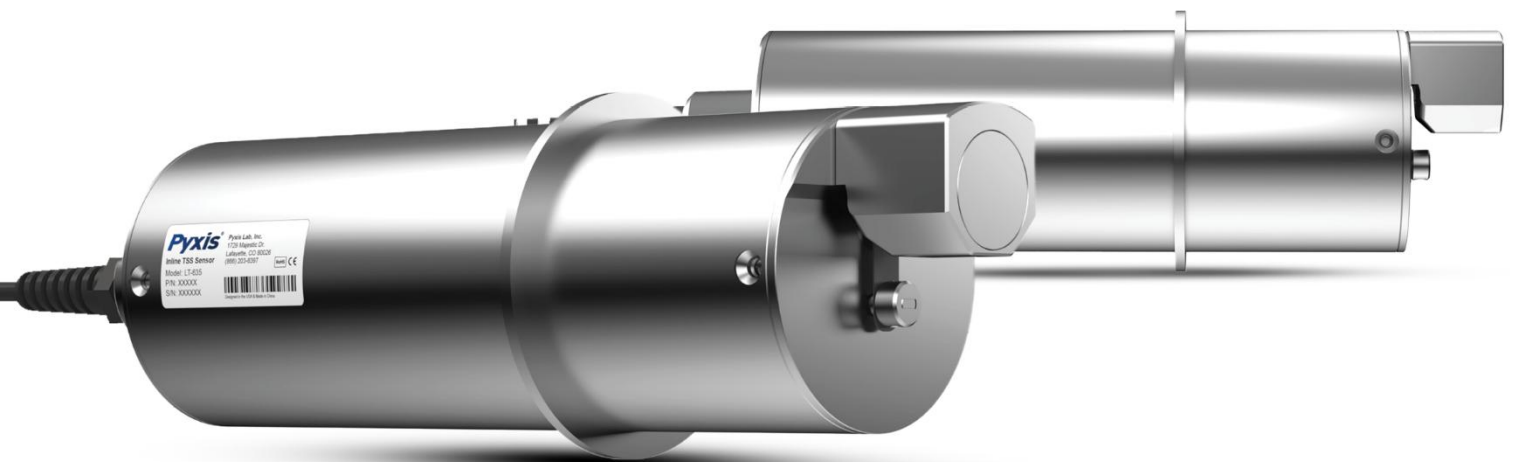

## Warranty Information

### Confidentiality

The information contained in this manual may be confidential and proprietary and is the property of Pyxis Lab, Inc. Information disclosed herein shall not be used to manufacture, construct, or otherwise reproduce the goods described. Information disclosed herein shall not be disclosed to others or made public in any manner without the express written consent of Pyxis Lab, Inc.

### Standard Limited Warranty

Pyxis Lab warrants its products for defects in materials and workmanship. Pyxis Lab will, at its option, repair or replace instrument components that prove to be defective with new or remanufactured components (i.e., equivalent to new). The warranty set forth is exclusive and no other warranty, whether written or oral, is expressed or implied.

### Warranty Term

The Pyxis warranty term is thirteen (13) months ex-works. In no event shall the standard limited warranty coverage extend beyond thirteen (13) months from original shipment date.

### Warranty Service

Damaged or dysfunctional instruments may be returned to Pyxis for repair or replacement. In some instances, replacement instruments may be available for short duration loan or lease.

Pyxis warrants that any labor services provided shall conform to the reasonable standards of technical competency and performance effective at the time of delivery. All service interventions are to be reviewed and authorized as correct and complete at the completion of the service by a customer representative or designate. Pyxis warrants these services for 30 days after the authorization and will correct any qualifying deficiency in labor provided that the labor service deficiency is exactly related to the originating event. No other remedy, other than the provision of labor services, may be applicable.

Repair components (parts and materials), but not consumables, provided during a repair, or purchased individually, are warranted for 90 days ex-works for materials and workmanship. In no event will the incorporation of a warranted repair component into an instrument extend the whole instrument's warranty beyond its original term.

### Warranty Shipping

A Repair Authorization (RA) Number must be obtained from Pyxis Technical Support before any product can be returned to the factory. Pyxis will pay freight charges to ship replacement or repaired products to the customer. The customer shall pay freight charges for returning products to Pyxis. Any product returned to the factory without an RA number will be returned to the customer. To receive an RMA you can generate a request on our website at <https://www.pyxis-lab.com/request-return-or-repair/>

### Pyxis Technical Support

Contact Pyxis Technical Support at +1 (866) 203-8397 or [service@pyxis-lab.com](mailto:service@pyxis-lab.com)

# Table of Contents

<b>1</b>	<b>Introducing the Pyxis LT-635 Sensor</b> .....	<b>3</b>
1.1	Features of the Pyxis LT-635.....	3
1.2	Specifications.....	4
1.3	Unpacking the Pyxis LT-635 Series Sensor.....	4
1.4	Standard Accessories.....	5
1.5	Optional Accessories .....	5
<b>2</b>	<b>Quick 4-20mA Start</b> .....	<b>6</b>
<b>3</b>	<b>Installation</b> .....	<b>7</b>
<b>4</b>	<b>Calibration and Diagnosis</b> .....	<b>9</b>
4.1	Calibration and Diagnosis by uPyxis Mobile APP .....	9
4.1.1	Calibration by uPyxis Mobile APP .....	10
4.1.2	Restore to factory.....	12
4.1.3	Diagnosis .....	13
4.1.4	Cleaning Period Adjustment.....	14
4.2	Calibration and Diagnosis by uPyxis Desktop APP .....	15
4.2.1	Calibration .....	17
4.2.2	Restore to Factory .....	19
4.2.3	Diagnosis .....	20
<b>5</b>	<b>Modbus RTU</b> .....	<b>20</b>
<b>6</b>	<b>Sensor Cleaning and Maintenance</b> .....	<b>21</b>
<b>7</b>	<b>Sensor Wiper Replacement Instructions</b> .....	<b>22</b>
<b>8</b>	<b>Contact Us</b> .....	<b>23</b>

# 1 Introducing the Pyxis LT-635 Sensor

The LT-635 is a submersible, waterproof, self-cleaning sensor that determines the concentration of suspended solids by measuring the attenuation of an infrared light source through the sample media. The instrument is virtually maintenance-free, and the self-cleaning capability of the sensor prevents deviations caused by air bubbles and sludge particulate. The LT-635 can be powered by a 24 VDC/6W power supply and offers fully integrated 4-20 mA and RS-485 Modbus output signals for connection to any controller, PLC or DCS network. When clean, the unique Pyxis sensor design offers a stability of <0.1g/L for up to 1-year without calibration. Additionally, the LT-635 can be wirelessly accessed via the MA-CR Bluetooth adapter for local display, diagnostics, cleaning, and calibration when using the **uPyxis APP** for mobile or desktop devices. The LT-635 is ideal for use in wastewater applications including clarifier/thickener sludge bed depth detection and activated aerobic or anoxic suspended solids detection.

## 1.1 Features of the Pyxis LT-635

The LT-635 includes the following features:

- Resolution as low as 0.1g/L
- Built-in transmitter, without preamplifier or meter head
- Combination 4-20mA isolated signal and RS-485 Modbus (RTU) output
- Simple / Wireless calibration using uPyxis Mobile or Desktop APPs and MA-CR Bluetooth Adapter
- Supports self-cleaning of sensor
- Optional Ultrasonic Adapter for automatic cleaning (in development)
- Optional calibration with Pyxis secondary standards or field water samples

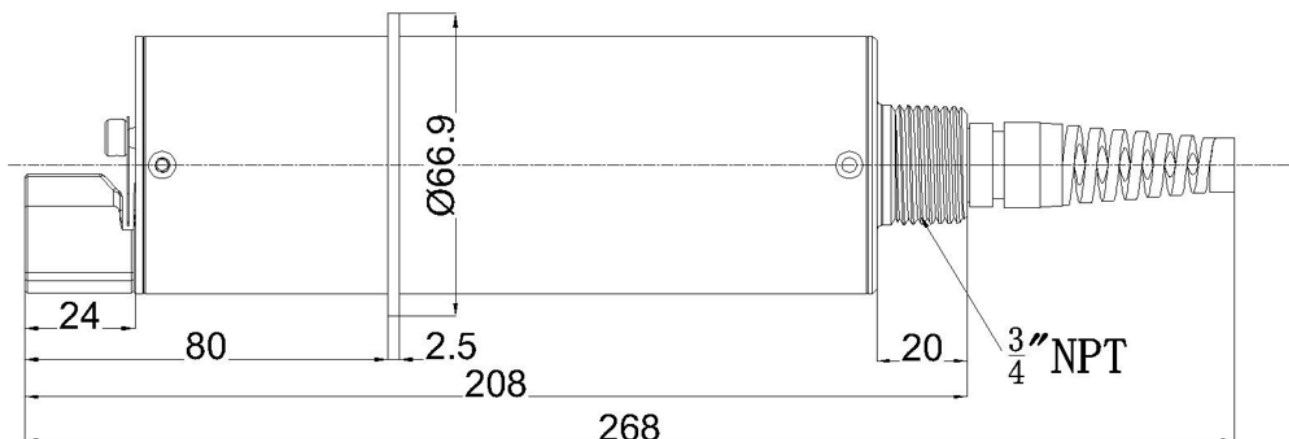

Figure 1 – LT-635 Dimensions (mm)

## 1.2 Specifications

Item	LT-635
P/N	53251
Parameter	Suspended Solids / Total Suspended Solids
Measurement Range	0.00-30g/L (0.00 – 30,000mg/L)
Unit	ppm (as SS or TSS)
Precision	± 0.1g/L or 5% of the value
Response Time	T95<10 Seconds
Calibration Method	Gravimetric Total Suspended Solids Analysis – Application Specific
Wavelength	850nm
Method	Absorbance
Power Supply	22 – 26VDC 6W
Operating Temperature	32 – 122 °F (0-50 °C)
Storage Temperature	-7 °C – 60 °C (20 – 140 °F)
Outputs	Isolated 4 – 20 mA Analog Output & Isolated RS-485 Digital Output
Installation	Submersed – Fixed Conduit ¾-inch MPNT Threaded Cable Fitting Submersed – Hoisting Chain or Cable Inline Tee Using ST-011 Stainless Steel Block Tee Assembly Sold Separately
Material	316 Stainless Steel – Body & Wiper Arm PTFE – Wiper Blade
Weight	1,530 g (3.3 lbs.)
Operational Pressure	45 psi (3.1 Bar)
Rating	IP-68, Fully Dustproof & Waterproof
Typical Wiper Life Span	12-18 Months (Avg. 10x/hour)
Regulation	CE / RoHS
Dimension (L x W x H)	(288mm x 57mm x 57mm)
Cable Length	33 feet (10m) w/IP-67 8-Pin adapter 4.9 feet (1.5m) flying lead w/IP-67 8-Pin adapter

*\*Pyxis Lab specifications are subject to change without notice*

## 1.3 Unpacking the Pyxis LT-635 Series Sensor

Remove the instrument and accessories from the shipping container and inspect each item for any damage that may have occurred during shipping. Verify that all items listed on the packing slip are included. If any items are missing or damaged, please contact Pyxis Customer Service at [service@pyxis-lab.com](mailto:service@pyxis-lab.com)

## 1.4 Standard Accessories

The following accessories are included in the LT-635 sensor package (as shown below)

- One LT-635 sensor with bulkhead terminated cable w/8-Pin Female Adapter (33 feet / 10m)
- One MA-1.5CR Flying Lead Cable w/8-Pin Male Adapter/Flying Lead (4.9 feet / 1.5m)
- One MA-CR Bluetooth / USB Adapter
- The full instrument manual is available for download at [www.pyxis-lab.com/shop/](http://www.pyxis-lab.com/shop/)



Figure 1 - LT-635 Sensor with 10m Terminated Cable + 1.5m Flying Lead Cable (MA-1.5CR) + MA-CR Bluetooth/USB Adapter

## 1.5 Optional Accessories

The following optional accessories can be purchased [order@pyxis-lab.com](mailto:order@pyxis-lab.com) or [www.pyxis-lab.com/shop/](http://www.pyxis-lab.com/shop/)

Accessory Name	Item Number
LT-635 Replacement Wiper Blade/Arm Assembly Kit <i>(Includes 5 sets of Wiper Blade with Arm)</i>	50700-A52
MA-CR <i>(Bluetooth Adapter/Display For use with Pyxis 8-Pin Sensors)</i>	MA-CR
UC-100A <i>(4 Sensor Pyxis Display/Data Logger RS-485/2x4-20mA/TCP)</i>	43054
MA-120-B Fixed Submersion Adapter Bracket <i>(Submersed Fixed Installation Mounting Bracket)</i>	50783
MA-50CR (50' Extension Cable w/8Pin Adapter)	50743
ST-011 <i>(Stainless Steel Block Tee Assembly for LT-635 3/4-inch FNPT)</i>	20385
MA-100CR (100' Extension Cable w/8Pin Adapter)	50744
Pyxis Sensor Cleaning Kit	SER-01

## 2 Quick 4-20mA Start

Follow the wiring table below to connect the LT-635 sensor to a controller or PLC. **\*NOTE\*** All Pyxis sensors provide a passive 4-20mA output signal, they are NOT LOOP POWERED. 24VDC+ power supply and 4-20mA+ signal are independent of each other in all Pyxis Lab sensors.

Color	Designation
Brown	Power GND
Green	RS-485 C
Yellow	RS-485 B
Gray*	4-20mA - (Internally connected to power ground)
Pink	Not Used
Blue	RS-485 A
White	4-20mA + (TSS)
Red	24V+
Silver	PE

**\*NOTE\*** The 24V- power ground (brown) and the 4-20 mA- (gray) return are internally connected. If the 24V- power ground and the 4-20 mA return in the controller are internally connected (non-isolated 4-20mA input), it is unnecessary to connect the 4-20 mA- (gray wire) to the 4-20 mA negative terminal in the controller. If a separate DC power supplier other than that from the controller is used, make sure that the output from the power supply is rated for 22-26 VDC @ 250mA.

Please refer to the table below for proper LT-635 input 4-20mA scaling in your receiving display, controller, or PLC.

LT-635 Output Scaling (4-20mA)		
mA	Value	Units
4	0	g/L
20	30	g/L

### 3 Installation

**Submersed Fixed Installation with MA-120-B:** The LT-635 may be installed in a submersed/fixed application using the MA-120-B Submersion Adapter Mounting Bracket (P/N: 50783). The LT-635 sensor should be installed as outlined in Figure 2 and 2A. For installation, the MA-120-B bracket should permanently mounted in a fixed position for easy access to the LT-635 sensor and piping. For sensor replacement and maintenance, users only need to lift (vertically/upwards) the sliding block and conduit with the mounted sensor from MA-120-B bracket. Please note the LT-635 outer diameter is  $\frac{3}{4}$  - inch NPT. A  $\frac{3}{4}$  to 1-inch NPT bushing is required for installation.

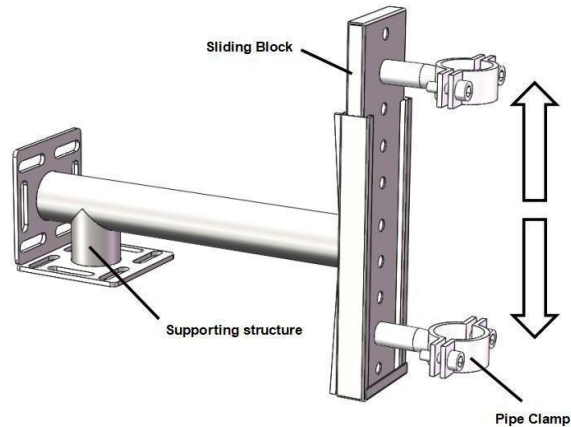

Figure 2 – MA-120-B Submersion Adapter Mounting Bracket

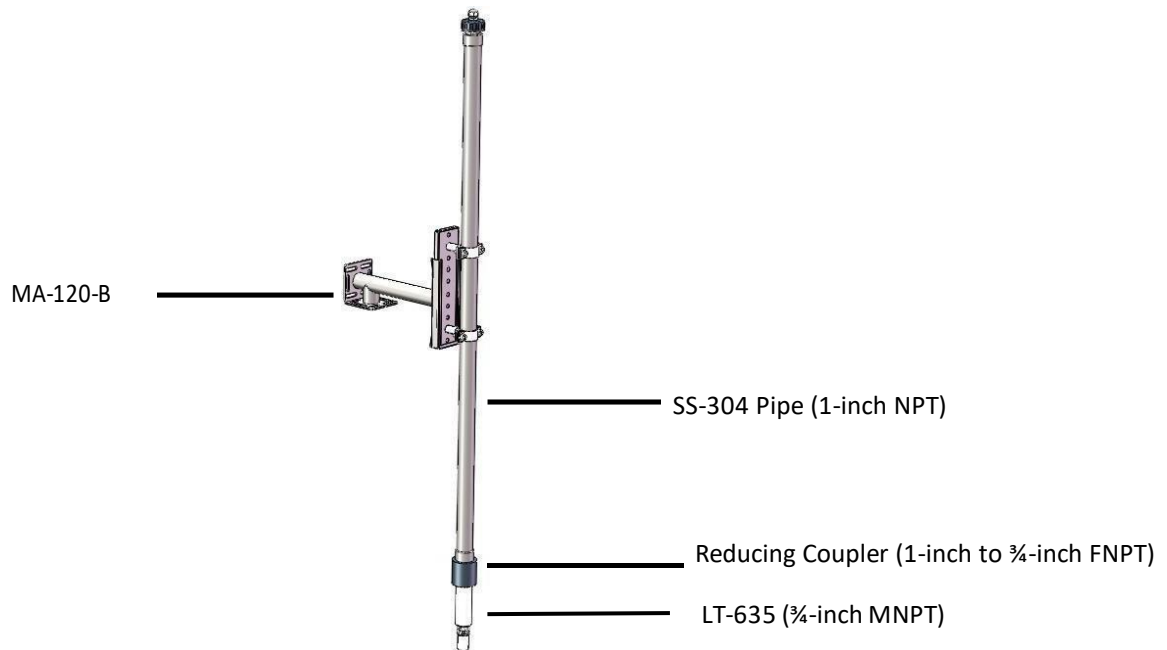
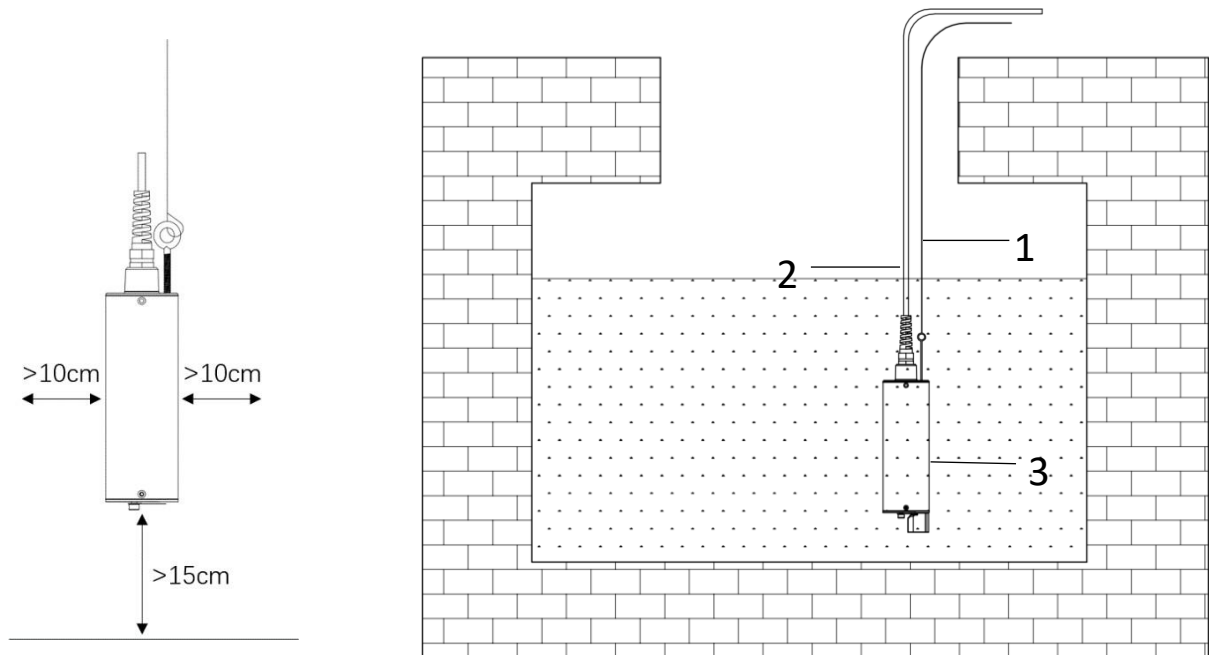

Figure 2A - Installation Using MA-120-B Submersion Bracket with Piping

**Submersed Installation with Lifting Ring:** The LT-635 sensor comes equipped with a lifting ring which allows the sensor to be lifted and lowered using a user-provided chain or cable. This method of installation enables use of the LT-635 in clarifier or thickener sludge bed depth profiling. Users may mark measurement increments on the user provided lifting chain/cable and the LT-635 sensor may be slowly lowered into the clarifier/thickener. When a drastic increase in suspended solids measurement is observed, the sensor has been exposed to the clarifier/thickener sludge bed. The lowered distance of the sensor to this observed TSS measurement change as indicated on the marked chain/cable can be used as a reference of the clarifier/thickener supernatant (clean water). This value when subtracted from the total clarifier/thickener height may be used as a reference to the sludge bed depth. For this method of installation and use, please refer to Figure 3. For sensor replacement and maintenance, users only need to lift the chain or cable and LT-635 Sensor vertically (upwards).



**IMPORTANT NOTE** – The LT-635 submersion suspended solids sensor must be installed no less than 15 cm from vessel bottom and 10cm from vessel wall for proper operation.

Reference ID	Name
1	Retention Chain / Cable
2	Sensor Output Cable
3	LT-635 Suspended Solids Sensor

Figure 3 - Submersed Installation Using the Lifting Ring

**ST-011 Inline Tee Installation** - The LT-635 sensor can now be installed in a bypass flow arrangement using the ST-011 inline stainless steel block flow tee assembly. This new tee is uniquely designed for use with the LT-635 sensor only and enables accurate and repeatable TSS value measurements in a by-pass flow arrangement. This sensor may be operated at pressures up to 45psi while inserted into the ST-011 tee assembly. Inlet and outlet line size is 3/4-inch FNPT. It is suggested for optimum performance that the ST-011 tee be mounted vertically with flow entering the bottom and exiting the top to ensure constant flooding.

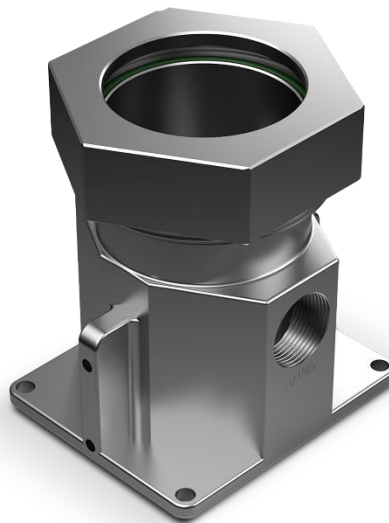
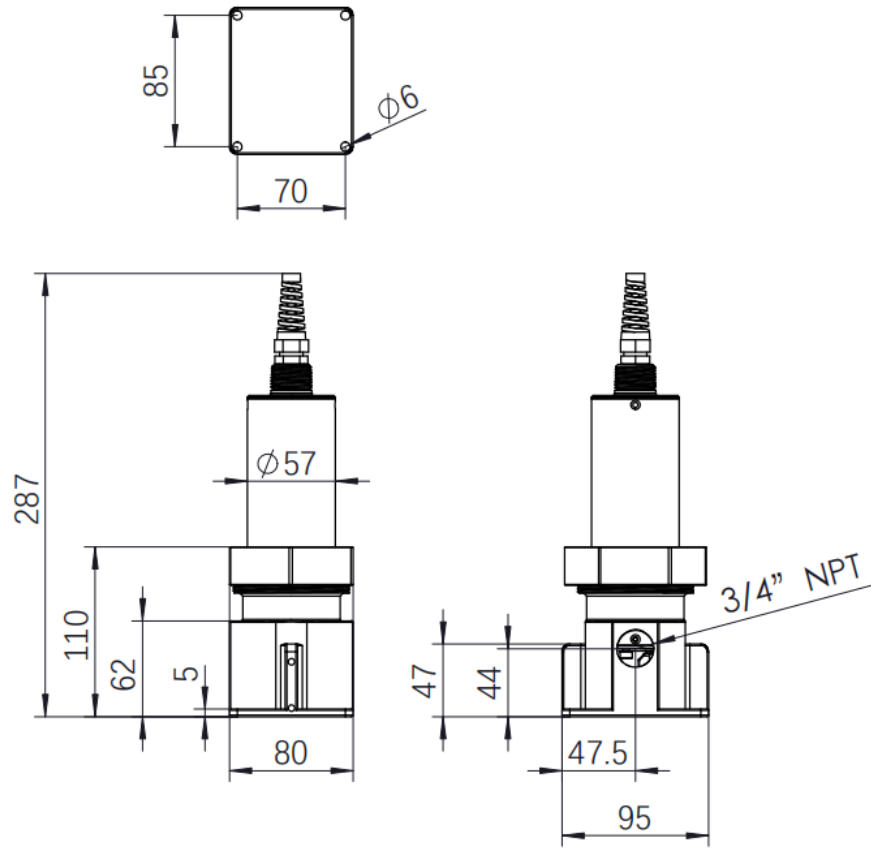

Figure 3A – ST-011 Inline Stainless Steel BLOCK Tee Assembly  
[service@pyxis-lab.com](mailto:service@pyxis-lab.com) | +1 (866) 203-8397

## 4 Calibration and Diagnosis

The LT-635 suspended solids sensor is rigorously calibrated before leaving the factory. As such, users do not need to calibrate the sensor for a period of one year if the sensor is maintained clean. Users can however calibrate the sensor according to their needs and as desired using the MA-CR Bluetooth adapter and uPyxis APP for mobile or desktop devices. Likewise, the LT-635 may also be calibrated after cleaning via PLC or controller through 4-20mA communication.



### 4.1 Calibration and Diagnosis by uPyxis Mobile APP

Connect and power the LT-635 sensor to a display, controller, or PLC. Insert the Pyxis MA-CR Bluetooth adapter (P/N: MA-CR) as shown in the following connection diagram, using the 8-pin adapters on the provided sensor cables. (Figure 4). The power should be sourced from a 24 VDC power terminal of the connected display, controller, or PLC. If a controller is not available, the LT-635 may also be powered via any 22-26 VDC power supply capable of 6W, that can directly connect to the LT-635 sensor with provided connection cables from Pyxis. **\*NOTE\*** The MA-CR provides a micro-display for local visibility of the sensor reading and mA value output.

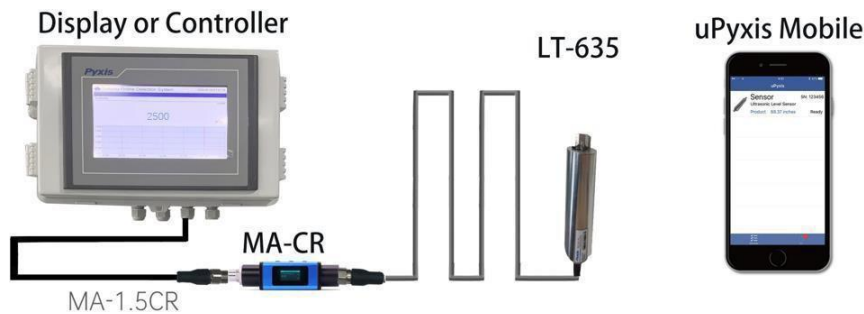

Figure 4 - LT-635 and MA-CR Bluetooth Adapter Powered By Connected Display, Controller or PLC

Download and install the uPyxis APP from Apple Store or Google Play per the QR codes provided in the image above. Be sure to turn on Bluetooth in the mobile device (please do not pair the device Bluetooth to any Pyxis device, the uPyxis APP will do the pairing). Open the uPyxis APP in the mobile device. Finger swipe the screen downward to refresh the screen and scan for the available Pyxis Bluetooth devices. The discovered devices will be listed (see Figure 6).

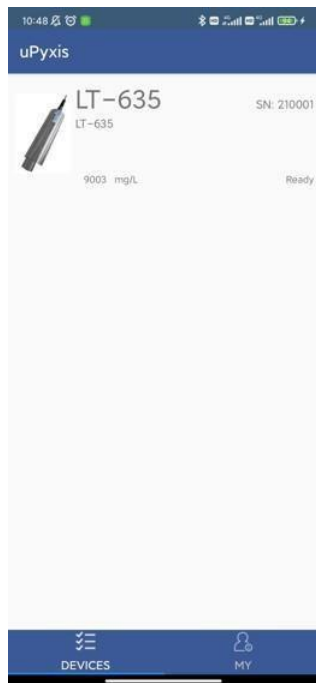

Figure 6

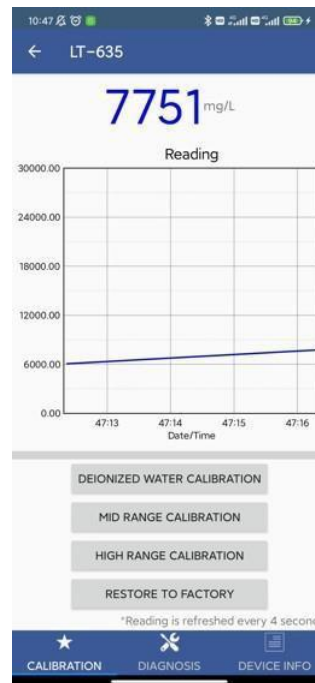

Figure 7

Tap the discovered LT-635 series sensor to connect to it via Bluetooth. The uPyxis APP can identify the sensor type if multiple Pyxis sensors are discovered in the scan.

As shown in Figure7, when connected via the MA-CR Bluetooth adapter, the uPyxis calibration page will display the current suspended solids concentration value being measured by the LT-635 sensor connected. Four functional tabs are available in this page: Deionized Water Calibration, Mid-Range Calibration, High-Range Calibration and Restore to Factory.

#### 4.1.1 Calibration by uPyxis Mobile APP

**IMPORTANT NOTE:** For proper calibration, the LT-63X sensor should be calibrated in an opaque oversized bucket and away from direct sunlight, with a minimum distance of >15cm from the bottom of water container to the lens of the sensor and a minimum of >10cm from the vessel wall on all sides.

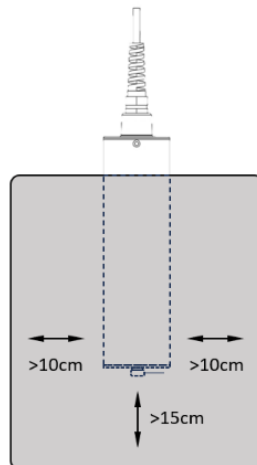

Figure 7A - Light Covered Oversized Bucket for Calibration with Sensor >15cm from bottom and >10cm from wall

Deionized Water Calibration Process - Remove the LT-635 sensor and rinse it thoroughly with deionized water. Repeat this rinse process three times. Wipe the sensor with a dust-free cloth or paper-towel to confirm that the sensor is free of obvious impurities. Insert the sensor in an opaque oversized bucket and away from direct sunlight. The LT-635 sensor should be calibrated with a minimum distance of >15cm from the bottom of water container to the lens of the sensor and a minimum of >10cm from the vessel wall on all sides. (as shown in Figure 7A). Inject bubble-free deionized water into the beaker and wait for the sensor reading to stabilize. Click the “Deionized Water Calibration” button after the reading stabilizes. If the calibration is successful, the interface will return a message "Calibration Succeeded" as shown in Figure 9. If the calibration has failed, the interface will return a message "Calibration Failed", as shown in Figure 10 and the user must repeat the process until calibration success is achieved.

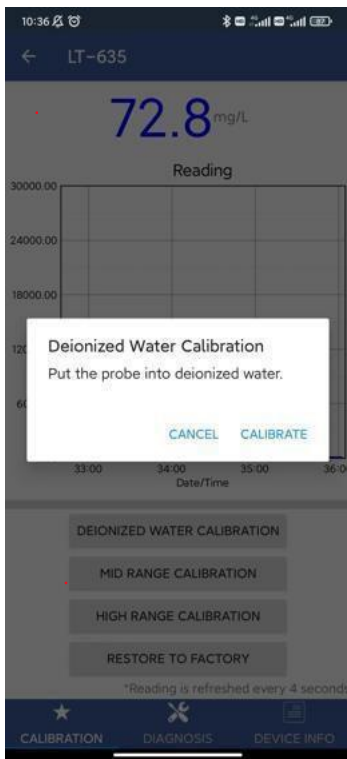

Figure 8

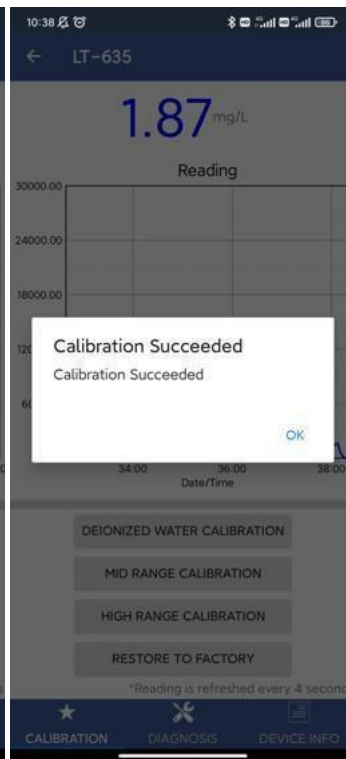

Figure 9

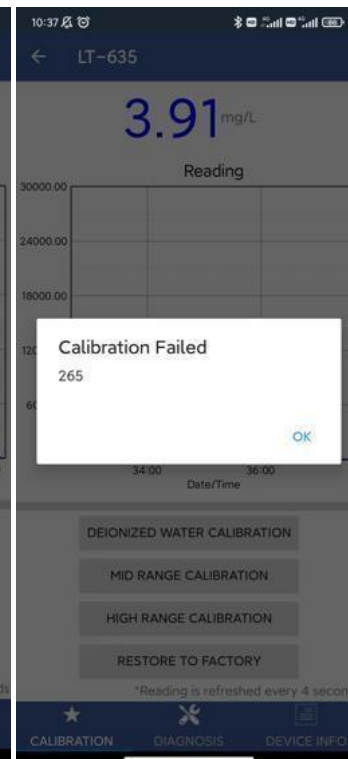

Figure 10

Mid-Range Calibration Process – After completing Deionized Water Calibration, remove and insert the LT-635 sensor into an opaque oversized bucket and away from direct sunlight and >15cm from container bottom and walls (as shown in Figure 7A) and inject the midpoint calibration solution. **\*NOTE\*** The midpoint calibration solution can be process water of the application itself, with a verified Total Suspended Solids (TSS) value in the range of 2,000 to 10,000 mg/L. The recommended method of TSS verification for the calibration solution being used is Gravimetric Total Suspended Solids determination. Wait until the reading stabilizes and then click the Midpoint Calibration button to calibrate the midpoint, as shown in Figure 11. If the calibration is successful, the interface will return a message "Calibration Succeeded". If the calibration has failed, the interface will return a message "Calibration Failed" and the user must repeat the process until calibration success is achieved.

High-Range Calibration Process - If the high range calibration is not required (>10,000mg/L), the user does not need to calibrate the high range. To continue with the high range calibration after completing Mid-Range calibration, remove and insert the LT-635 sensor into an opaque oversized bucket and away from direct sunlight and >15cm from container bottom and walls (as shown in Figure 7A) and inject the High Point calibration solution. **\*NOTE\*** *The high point calibration solution can be process water of the application itself, with a verified Total Suspended Solids (TSS) value in the range of 10,000 to 30,000 mg/L. The recommended method of TSS verification for the calibration solution being used is Gravimetric Total Suspended Solids determination.* Wait until the reading stabilizes and then click the High Point Calibration button to calibrate the highpoint, as in Figure 12. If the calibration is successful, the interface will return a message "Calibration Succeeded". If the calibration has failed, the interface will return a message "Calibration Failed" and the user must repeat the process until calibration success is achieved.

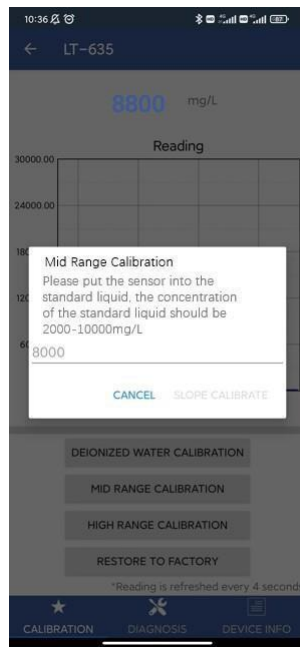

Figure 11

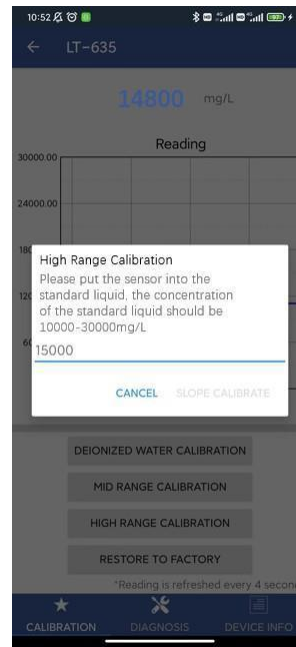

Figure 12

### Trouble Shooting Steps for Failed Calibration Messages

- The Deionized water has not been contaminated.
- The standard solution is accurately pre-measured to verify Total Suspended Solids.
- The sensor is clean and not contaminated with debris or other materials.

## 4.1.2 Restore to Factory

Restore To Factory– If user wants to restore the sensor calibration to factory default parameters, as shown in Figure13, click the OK option to confirm. If the restoration is successful, the interface will return a message "Restore Succeed" (Figure 14).



Figure 13

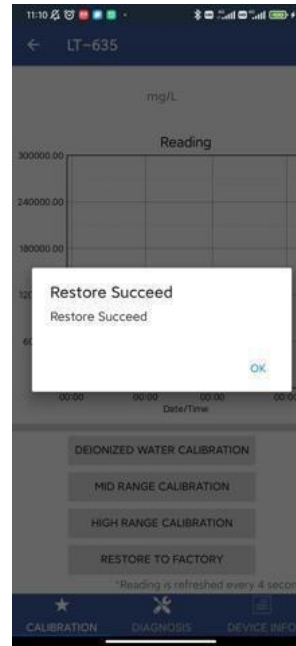

Figure 14

### 4.1.3 Diagnosis

Tap Diagnosis in the bottom of the APP page to launch the diagnosis page (Figure 15) .

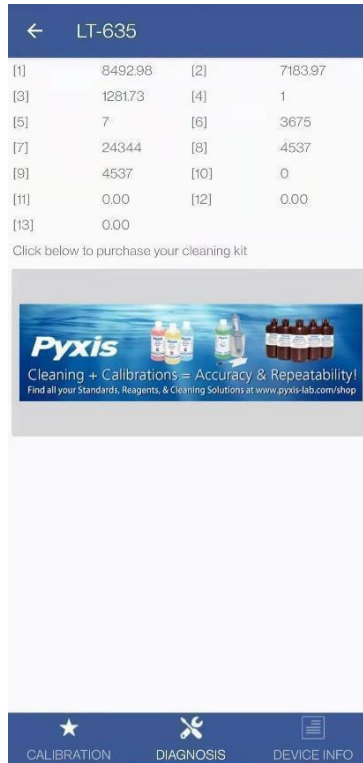

Figure 15 - Select Diagnosis for Sensor

Export/Upload Sensor Diagnosis Data - In this page, the raw data measured by the sensor is displayed. To help troubleshooting possible issues with the sensor, please save images of these data when the sensor is respectively placed in a clean water (tap water or deionized water), in a known Suspended Solids Standard Solution and/or in the sample that the sensor is intended for. This data may be exported from the uPyxis APP via email to [service@pyxis-lab.com](mailto:service@pyxis-lab.com) for technical support.

#### 4.1.4 Cleaning Period Adjustment

Tap Device info in the bottom of the uPyxis APP page to launch the Device info page (Figure 16). You can set the **Device Name**, **Product Name**, **Modbus Address** and **Brush Setting** for the LT-635 sensor. Press **Brush Once** to activate the wiper arm manually. Be sure to press **Apply Settings** to save any changes.

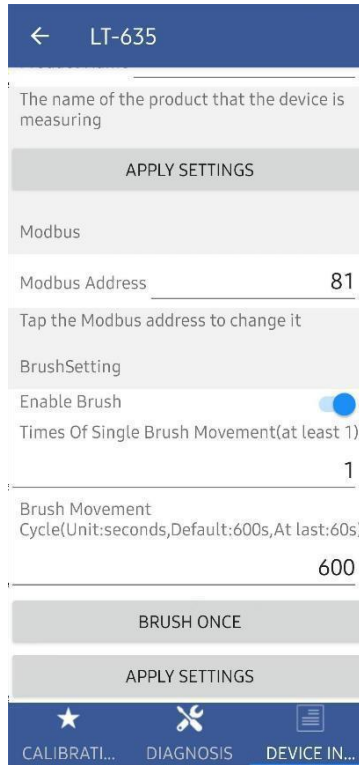

Figure 16 - Cleaning Period Adjustment

## 4.2 Calibration and Diagnosis by uPyxis Desktop APP

- 1) Download and install uPyxis Desktop APP from

<https://upyxis.pyxis-lab.com.cn/release/pc/uPyxis.Setup-latest.zip>

- 2) Connect a USB Type-C cable to the port at the bottom of the MA-CR and to the USB port of the laptop or computer. This will provide power to the MA-CR from the laptop/computer. Connect the MA-CR to the LT-635 sensor. The MA-CR Bluetooth adapter will boost the 5V of the regular USB to 24V to power the sensor for use with uPyxis Desktop.

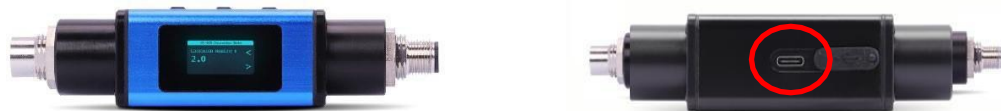

MA-CR Bluetooth Adapter – Bottom USB-C

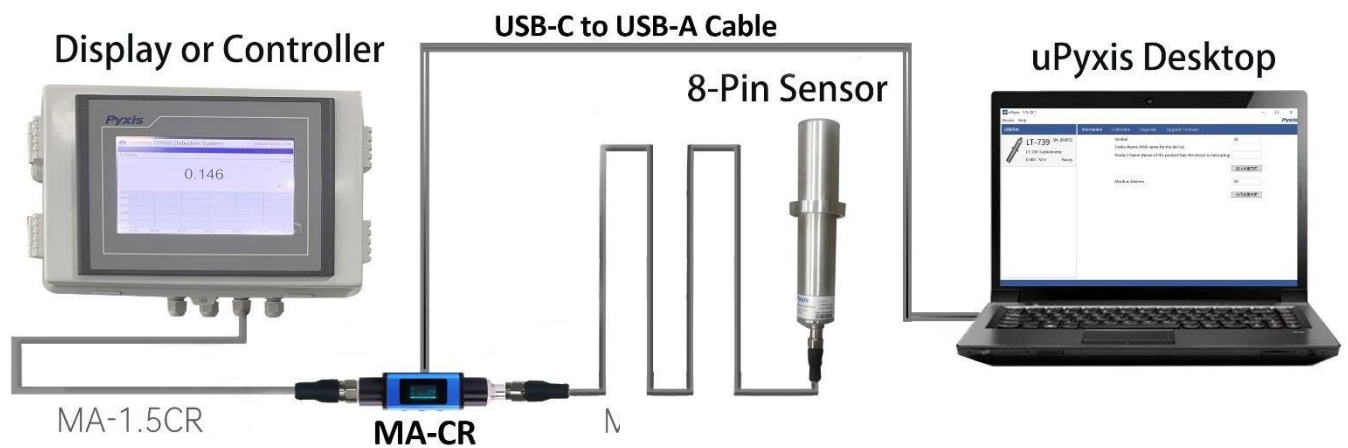

Figure 12 – MA-CR Connected to Sensor & Laptop

- 3) Set the MA-CR to operate in USB Mode by following the steps below.
  - a. Once the MA-CR screen is powered Press ◀ or ▶ until you arrive at (USB to RS485) screen.
  - b. Press the **OK** Button.
  - c. Follow Prompts below to Enable USB feature. Once enabled, you may connect to uPyxis.



- 4) Open the desktop uPyxis APP.
- 5) Click Device to launch the connection option menu.
- 6) Select Connect via USB-RS485 (Figure 18).
- 7) Select the Comm Port to make a connection. Normally only one Comm port is identified by uPyxis (Figure 19). If more than one Comm port listed in the selection dropdown, you may try to select each one to see if a connection can be made. Alternatively, you may use the Windows Device Manager to identify the Comm Port that the Pyxis USB adapter is using.

After the connection is established, the LT-635 sensor series number and current turbidity concentration reading of the water will be displayed on the left of the information page (**Error! Reference source not found.20** ). In this page, you can set the **Device Name**, **Product Name**, **Modbus Address** and **Brush Setting** for the device.

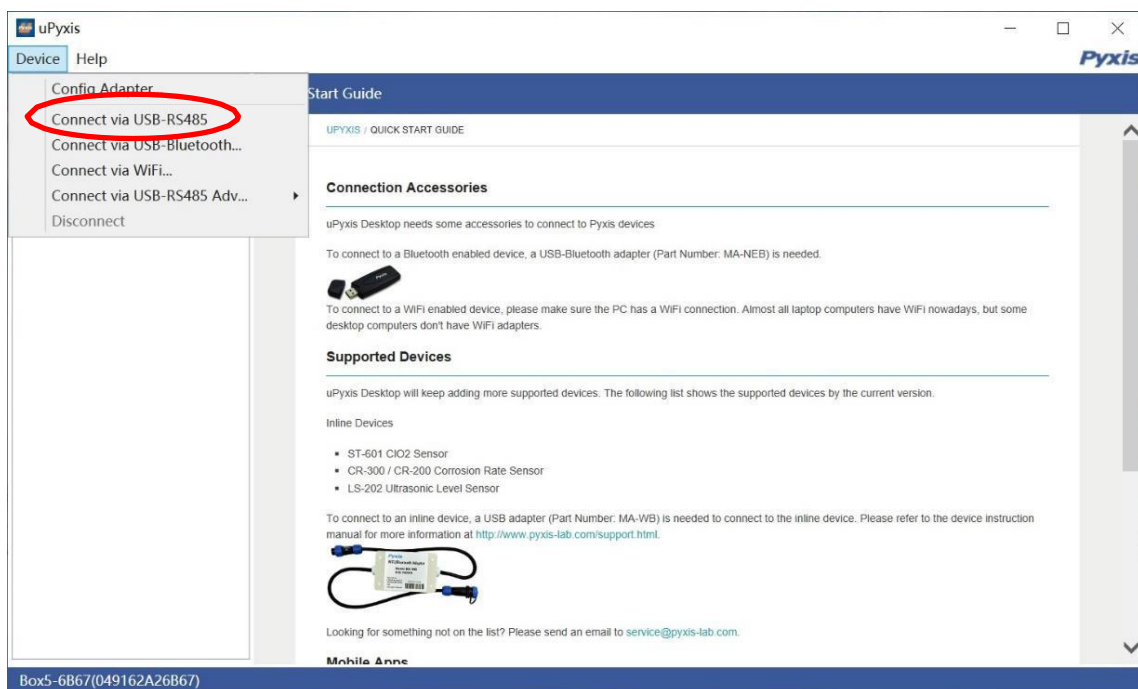

Figure 18 - Connection Options

After the connection is established, the LT-635 sensor series number and current suspended solids concentration reading of the water will be displayed on the left of the information page (Figure ). In this page, you can set the **Device Name**, **Product Name**, **Modbus Address** and **Brush Setting** for the device. Click Calibration to launch the calibration (Figure 21).

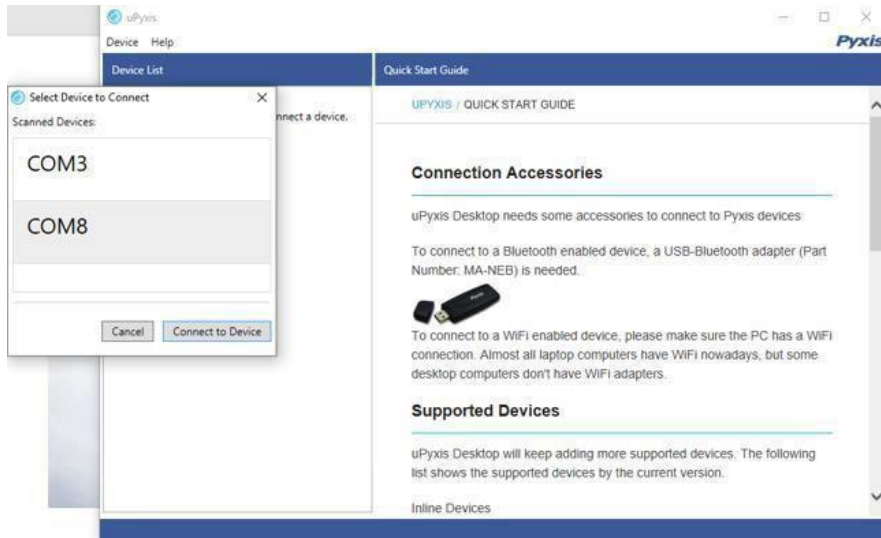

Figure 19 - Select a Comm Port

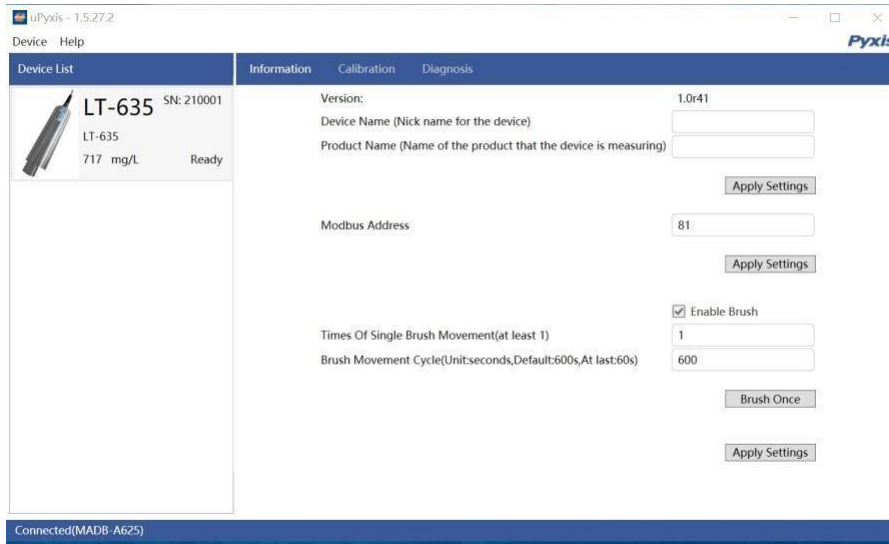

Figure 20 - Connected to a LT-635 sensor and information page

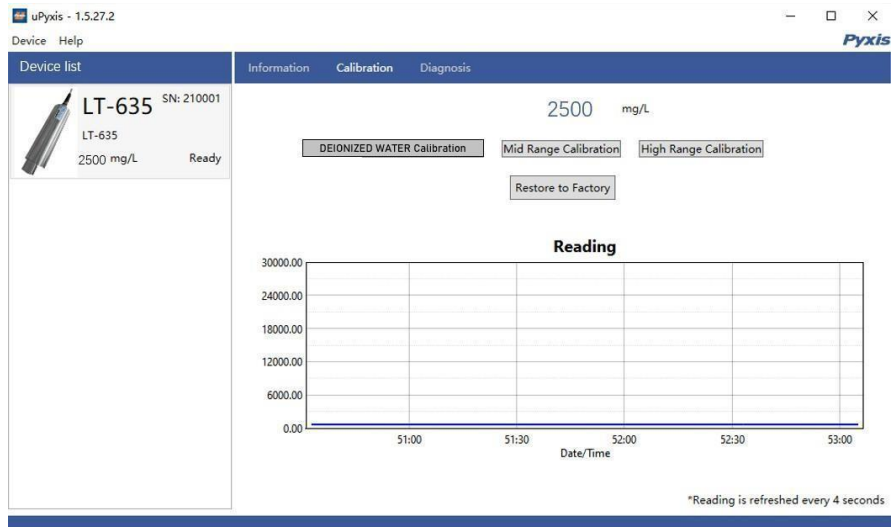

Figure 21 - Calibration Page

## 4.2.1 Calibration

Deionized Water Calibration Process - Remove the LT-635 sensor and rinse it thoroughly with deionized water. Repeat this rinse process three times. Wipe the sensor with a dust-free cloth or paper-towel to confirm that the sensor is free of obvious impurities. Insert the sensor in an opaque oversized bucket and away from direct sunlight. The LT-635 sensor should be calibrated with a minimum distance of >15cm from the bottom of water container to the lens of the sensor and a minimum of >10cm from the vessel wall on all sides. (as shown in Figure 7A). Inject bubble-free deionized water into the beaker and wait for the sensor reading to stabilize. Click the “Deionized Water Calibration” button after the reading stabilizes. If the calibration is successful, the interface will return a message "Calibration Succeeded". If the calibration has failed, the interface will return a message "Calibration Failed" and the user must repeat the process until calibration success is achieved.

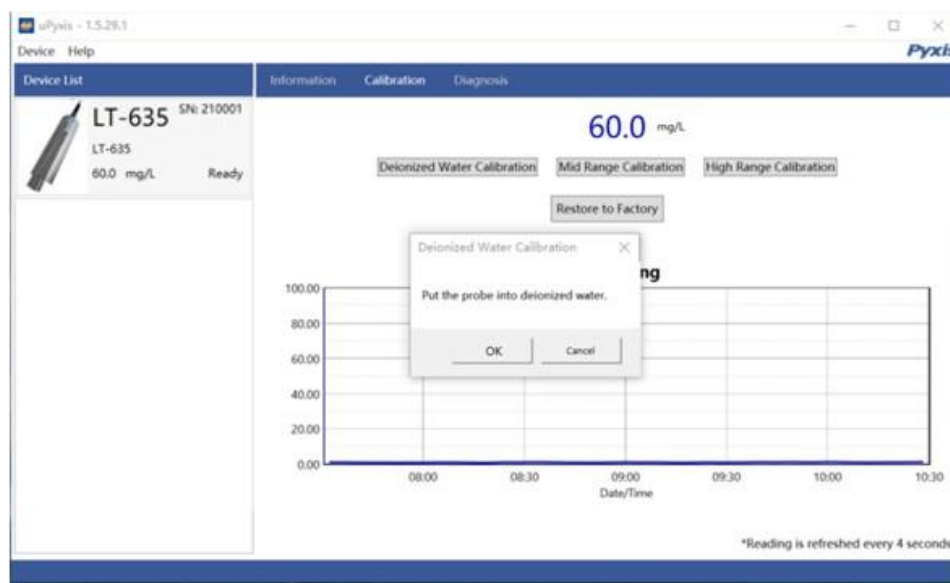

Figure 22 - Deionized Water Calibration

Mid-Range Calibration Process – After completing Deionized Water Calibration, remove and insert the LT-635 sensor into an opaque oversized bucket and away from direct sunlight and >15cm from container bottom and walls (as shown in Figure 7A) and inject the midpoint calibration solution. **\*NOTE\*** The midpoint calibration solution can be process water of the application itself, with a verified Total Suspended Solids (TSS) value in the range of 2,000 to 10,000 mg/L. The recommended method of TSS verification for the calibration solution being used is Gravimetric Total Suspended Solids determination. Wait until the reading stabilizes and then click the Midpoint Calibration button to calibrate the midpoint, as shown in Figure 23. If the calibration is successful, the interface will return a message "Calibration Succeeded". If the calibration has failed, the interface will return a message "Calibration Failed" and the user must repeat the process until calibration success is achieved.

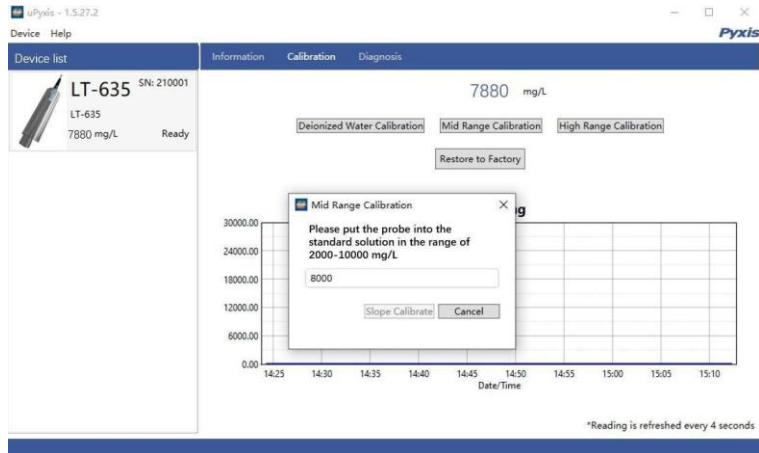

Figure 23 - Mid-Range Calibration

**High-Range Calibration Process** - If the high range calibration is not required ( $>10,000\text{mg/L}$ ), the user does not need to calibrate the high range. To continue with the high range calibration after completing Mid-Range calibration, remove and insert the LT-635 sensor into an opaque oversized bucket and away from direct sunlight and  $>15\text{cm}$  from container bottom and walls (as shown in Figure 7A) and inject the High Point calibration solution. **\*NOTE\*** The high point calibration solution can be process water of the application itself, with a verified Total Suspended Solids (TSS) value in the range of 10,000 to 30,000 mg/L. The recommended method of TSS verification for the calibration solution being used is Gravimetric Total Suspended Solids determination. Wait until the reading stabilizes and then click the High Point Calibration button to calibrate the highpoint, as in Figure 24. If the calibration is successful, the interface will return a message "Calibration Succeeded". If the calibration has failed, the interface will return a message "Calibration Failed" and the user must repeat the process until calibration success is achieved.

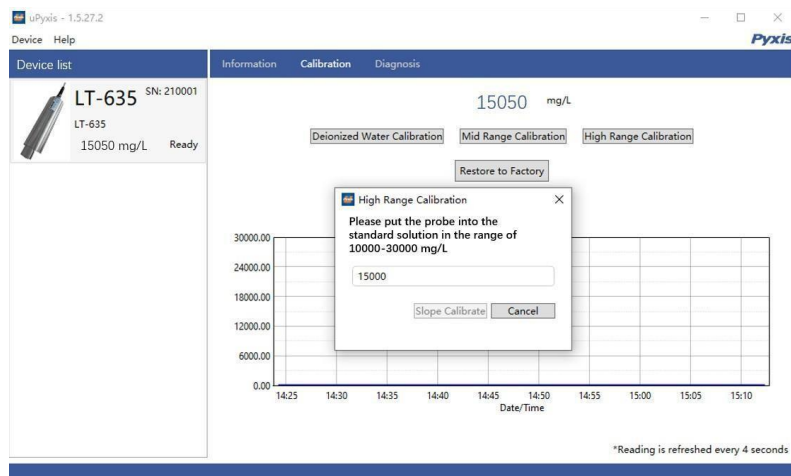

Figure 24 - High-Range Calibration

## Trouble Shooting Steps for Failed Calibration Messages

- The Deionized water has not been contaminated.
- The standard solution is accurately pre-measured to verify Total Suspended Solids.
- The sensor is clean and not contaminated with debris or other materials.

### 4.2.2 Restore to Factory

Restore To Factory – If user wants to restore the sensor calibration to factory default parameters, as shown in Figure 25, click the OK option to confirm. If the restoration is successful, the interface will return a message "Restore Succeed".

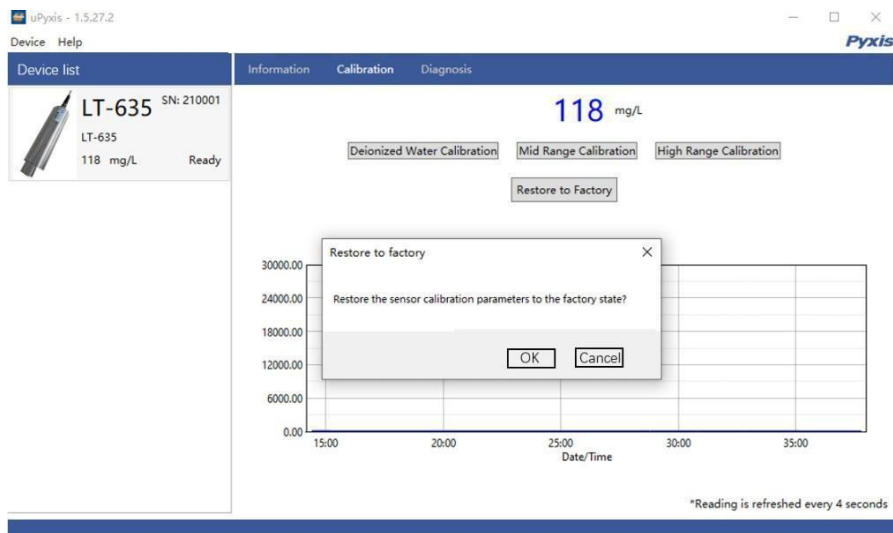

Figure 25 - Restore to Factory

### 4.2.3 Diagnosis

Export/Upload Sensor Diagnosis Data - In this page, the raw data measured by the sensor is displayed. To help troubleshooting possible issues with the sensor, please save images of these data when the sensor is respectively placed in a clean water (tap water or deionized water), in a known Suspended Solids Standard Solution and/or in the sample that the sensor is intended for. This data may be exported from the uPyxis APP via email to [service@pyxis-lab.com](mailto:service@pyxis-lab.com) for technical support.

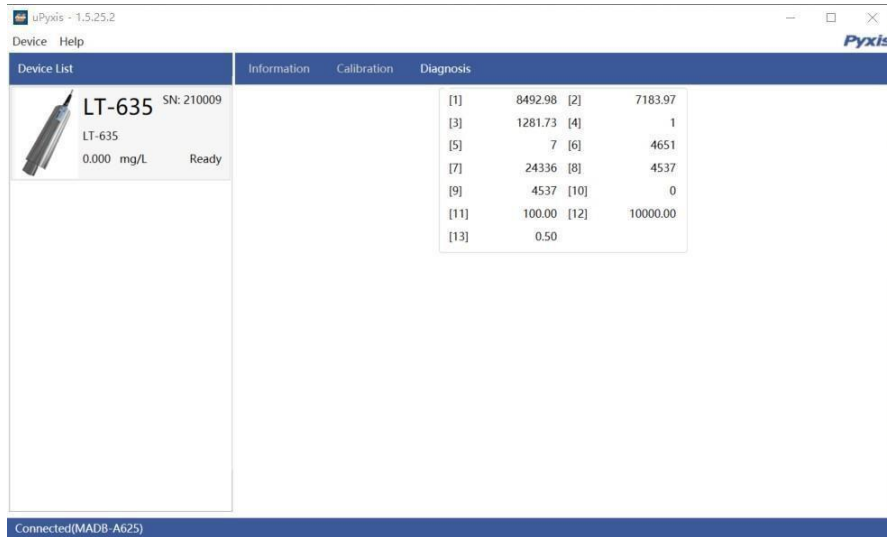

Figure 26 - Select Diagnosis Condition

## 5 Modbus RTU

The LT-635 sensor is configured as a Modbus slave device. In addition to the Total Suspended Solids value, other operational parameters, including warning and error messages, are available via a Modbus RTU connection. Contact Pyxis Lab Customer Service [service@pyxis-lab.com](mailto:service@pyxis-lab.com) for more information.

## 6 Sensor Cleaning and Maintenance

The LT-635 sensor is designed to provide reliable and continuous Total Suspended Solids readings. Although a self-cleaning feature has been added, heavy fouling can prevent light from reaching the sensor and may affect the accuracy of the sensor, depending on application conditions.

The LT-635 sensor is designed to be easily removed, inspected, and cleaned if required.

Aged heavy deposition, especially inorganic deposits such as iron oxide and calcium carbonate, can be removed by submersing and soaking (15 minutes) the LT-635 sensor into the Pyxis Sensor Cleaning Solution Kit available from Pyxis online Estore/Catalog <https://www.pyxis-lab.com/product/inline-sensor-cleaning-kit/>



Figure 27 – Pyxis Probe Cleaning Solution Kit (P/N: SER-01)

## 7 Sensor Wiper Replacement Instructions

Replacement of cleaning parts requires a total of 7 steps.

**Step 1** Set the wiper arm assembly to a horizontal position after powering off the sensor

**Step 2** Remove the M2 screw that holds the nut

**Step 3** Remove the nut that retains the wiper arm assembly

**Step 4** Remove the old wiper arm assembly

**Step 5** Install the wiper arm assembly to the sensor

**Step 6** Install the new nut on the sensor

**Step 7** Install the new M2 screw into the nut

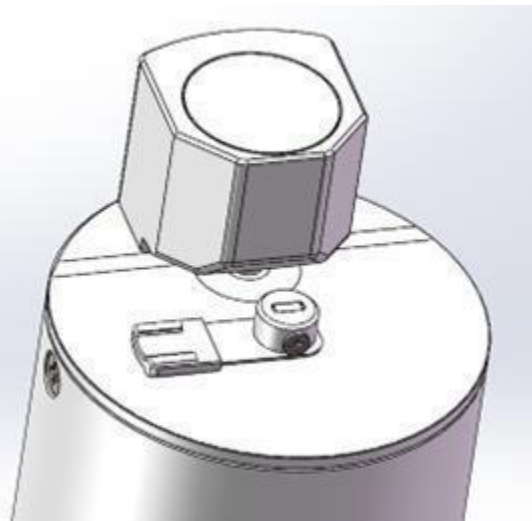

*Figure 28 -Set wiper arm to horizontal position*

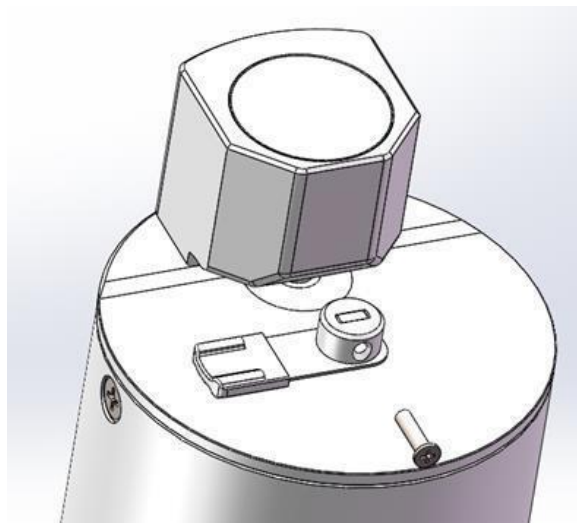

*Figure 29 - Take out the M2 screw that fixes the nut*

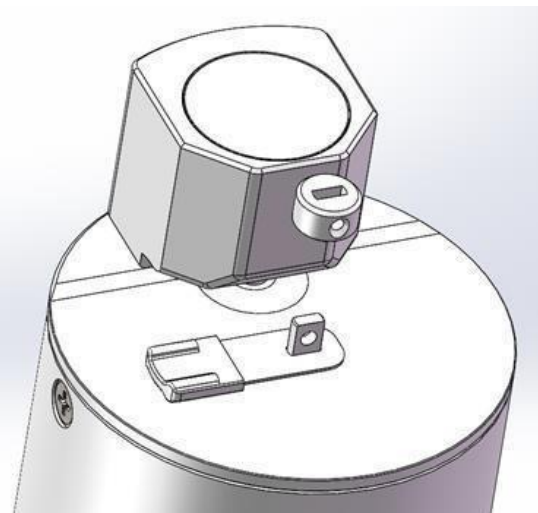

*Figure 30 -Remove the nut*

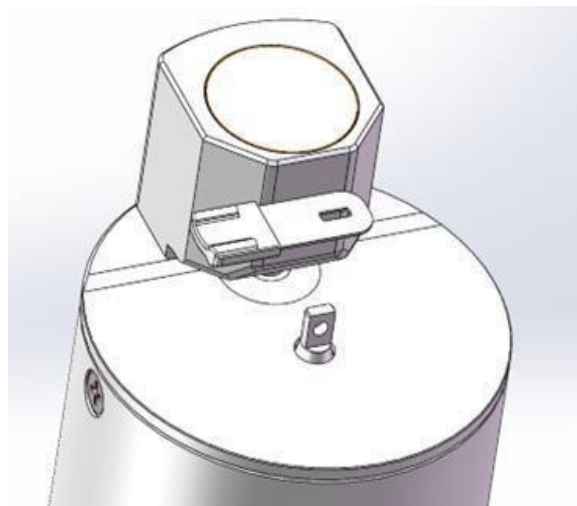

*Figure 31 Remove the old wiper arm assembly*

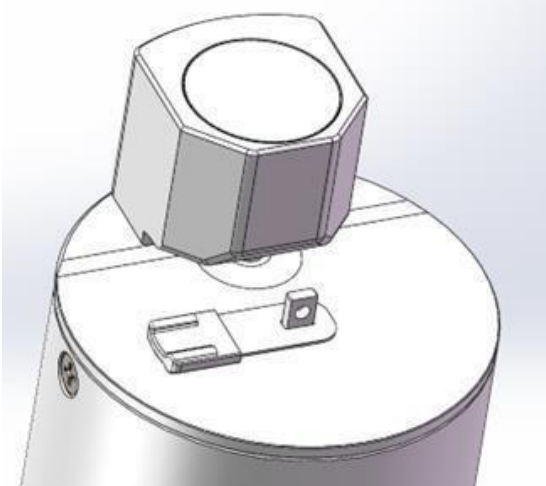

*Figure 32 - Install the wiper arm assembly*

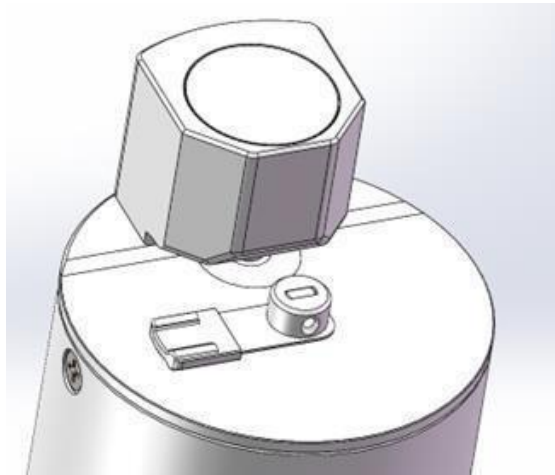

*Figure 33 - Install the new nut on the sensor*

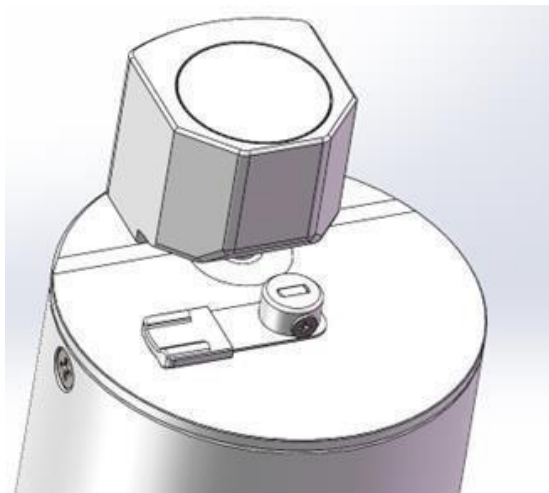

*Figure 34 -Install the new M2 screw into the nut*

## 8 Contact Us

Contact us if you have questions about the use or maintenance of the LT-635 sensors:

**Pyxis Lab, Inc.**

21242 Spell Circle

Tomball, TX. 77380

1-866-203-8397

[www.pyxis-lab.com](http://www.pyxis-lab.com)

[service@pyxis-lab.com](mailto:service@pyxis-lab.com)