



# LSR-80X Series Radar Level Sensors

Installation & Technical Application Guide



**Pyxis Lab® Inc.**  
21242 Spell Circle  
Tomball, TX 77375  
[www.pyxis-lab.com](http://www.pyxis-lab.com)

TECHNICAL  
GUIDE

# Table of Contents

1. LSR-803(L) Parameter Settings.....	2
1.1 Unit Settings via uPyxis 2.0.....	2
1.2 Measurement Mode Settings .....	3
1.3 Screen Off-Time Settings .....	5
Application Case 1 .....	6
1.4 Radar Level Sensor Display Unit Settings.....	7
1.5 Working Mode Settings .....	8
2. Measurement Parameters Configuration .....	9
2.1 Dead Zone Settings (Contact and Non-Contact).....	9
Application Case 2.....	10
2.2 Distance Offset Settings.....	11
Application Case 3 .....	12
2.3 Interference Signal Blocking (Big Change Enable Feature) .....	13
Application Case 4 .....	14
2.4 Installation Angle Verification with uPyxis .....	15
2.5 Use of VAPOR-BARRIER Well Insert Adapter for Amines/Ammonia.....	16
2.6 Diagnosis Parameter.....	17
3. Communication Parameters Setting .....	18
3.1 RS-485 Parameters Setting .....	18
3.2 LoRa Parameters.....	19
4. Firmware Upgrade.....	21
5. Data Log & Download for LSR-803(L) Only.....	22

# 1. LSR-803(L) Parameter Settings

## 1.1 Unit Settings via uPyxis 2.0

Customers can select metric or imperial units on the uPyxis 2.0 setup page. The radar level measurements (level, distance, and volume) will be displayed in uPyxis according to the uPyxis unit settings. When metric units are selected, levels and distances are displayed in meters and volumes are displayed in liters; when imperial units are selected, levels and distances are displayed in inches and volumes are displayed in gallons. **\*NOTE\*** that the LSR-803(L) Radar Level Sensor has its own unit settings for the level, distance and volume displayed on its OLED screen.

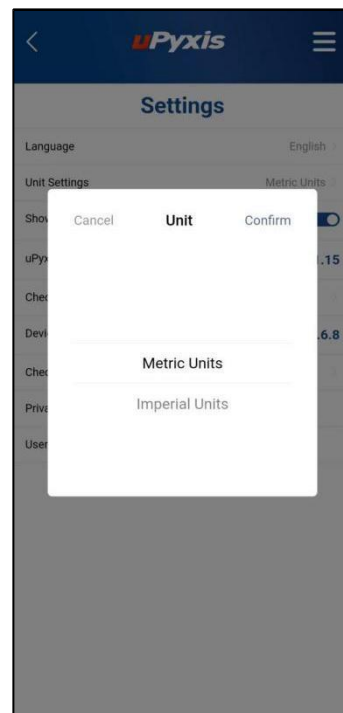
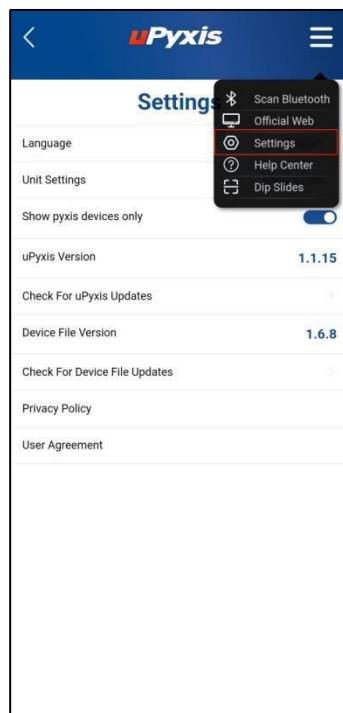

## 1.2 Measurement Mode Settings

LSR-803(L) supports continuous measurement and interval measurement mode. Continuous measurement is only supported when the radar level sensor is powered by 24VDC power supply, interval measurement is available when radar level sensor is powered by 24VDC or by 4 AA alkaline batteries.

**\*NOTE\***: *The radar level sensor can work in continuous mode for a short period of time when it is AA-battery powered, this can be very useful when user carrying out on-site installation and commissioning the device. However, if there are no user interactions (via button pressing or uPyxis connection) with level sensor for more than 10 minutes, the level sensor will switch to one-hour interval measurement automatically.*

Measuring Period	LSR-803L Battery Life (Days)
15 Minutes	50
30 Minutes	90
1 Hour	160
2 Hours	260
4 Hours	380
8 Hours	490
12 Hours	545
24 Hours	600

**\*NOTE\*** *The above data are actual measured values and derived calculations for reference only.*

LSR-803L

Trend Chart OverView **Configuration** Datalog Upgrade

Modbus Parity	EVEN	
Modbus Baudrate	9600	
Unit	inch/gallon	
Measure Time	24 hour	
Screen off time	2 min	
Working Mode	Tank	
BigChangeEnable	Enable	
BigChangeSkipCnt	60	
BigChangeThreshold	0.3	
FilterCoefficient	1	
Dead Zone	0 m	
DistOffset	0 m	
AOMode	normal	
Measure Period	500 ms	

LSR-803L

Trend Chart OverView **Configuration** Datalog Upgrade

Configuration

Cancel **Measure Time** Confirm

Continuous

30 s

1 min

2 min

Advanced Settings

Tank Configuration

LoRa

Information

LoRa ID 9

### 1.3 Screen Off-Time Settings

Use the uPyxis App to set screen off time of LSR-803(L).

**\*IMPORTANT NOTE\*** - The screen off time setting is only valid when the radar level sensor works in continuous mode. In interval measurement mode, the radar level sensor will stop working and enter sleep mode between intervals and the screen is powered off during sleeping.

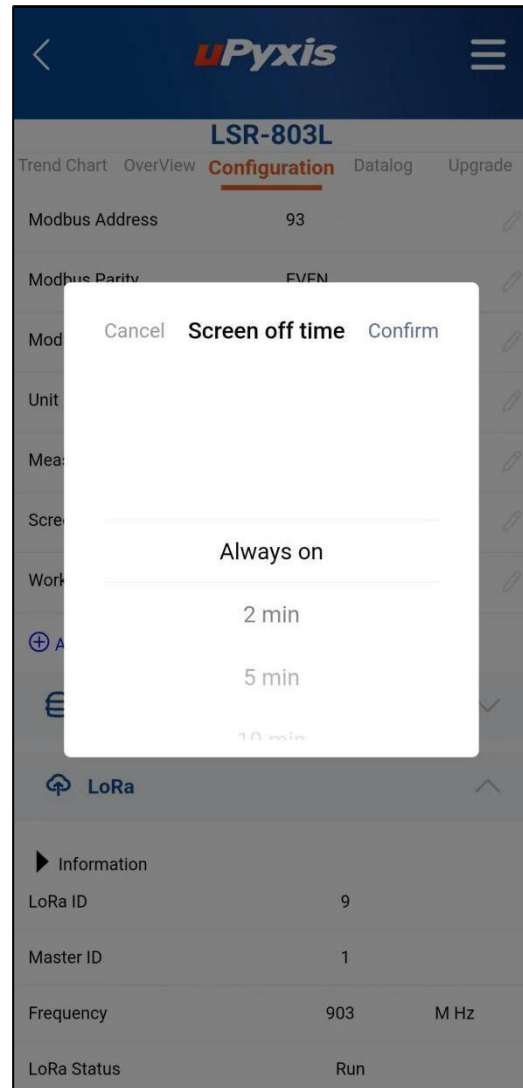
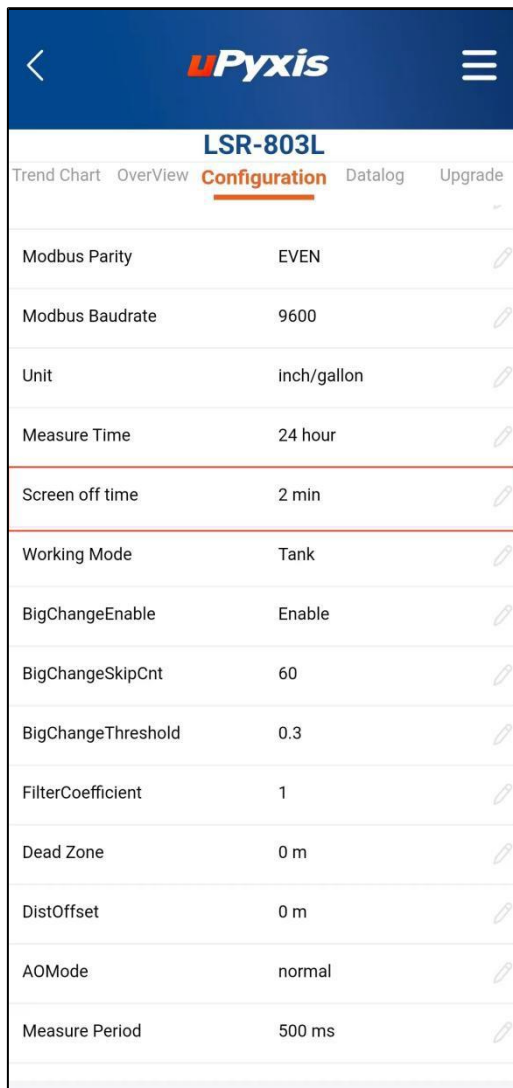

## Application Case 1

<b>Application Site</b>	Asia Pacific Wastewater Treatment Plant
<b>Device Model</b>	LSR-803
<b>Power Supply</b>	24VDC
<b>Communication</b>	4-20mA output
<b>Working Mode</b>	Continuous measurement
<b>Request</b>	Customer requires the screen be always ON to allow the field person to check the level data at any time.
<b>Solution</b>	Set the LSR-803 screen always on via uPyxis App.

## 1.4 Radar Level Sensor Display Unit Settings

Use uPyxis to set the LSR-803(L) screen display units.

- inch / gallon
- meter / liter
- centimeter / liter

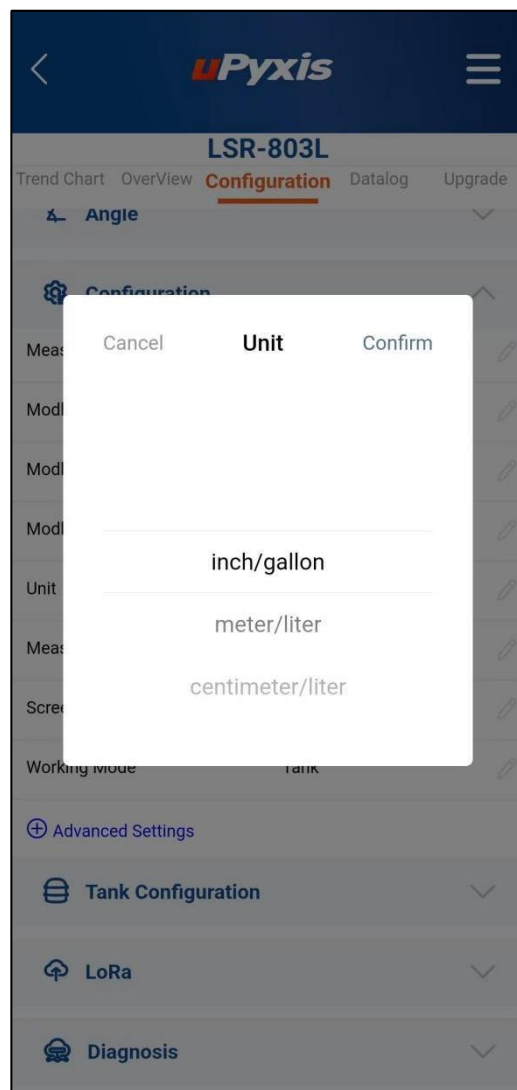
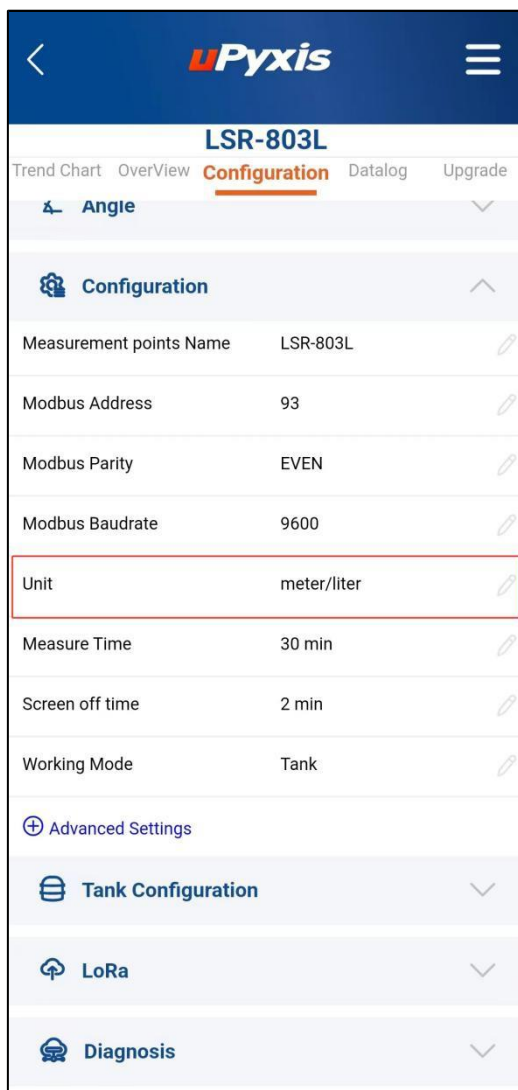

## 1.5 Working Mode Settings

The Pyxis Radar level sensors support **TANK** mode and **POOL** (Open Water) mode. Tank mode requires the user to specify tank volume parameter in addition to tank height parameter enabling the radar level sensor to calculate and display the consumed volume and remaining volume values. When in Pool (Open Water) mode, only the level and distance measurements will be displayed.

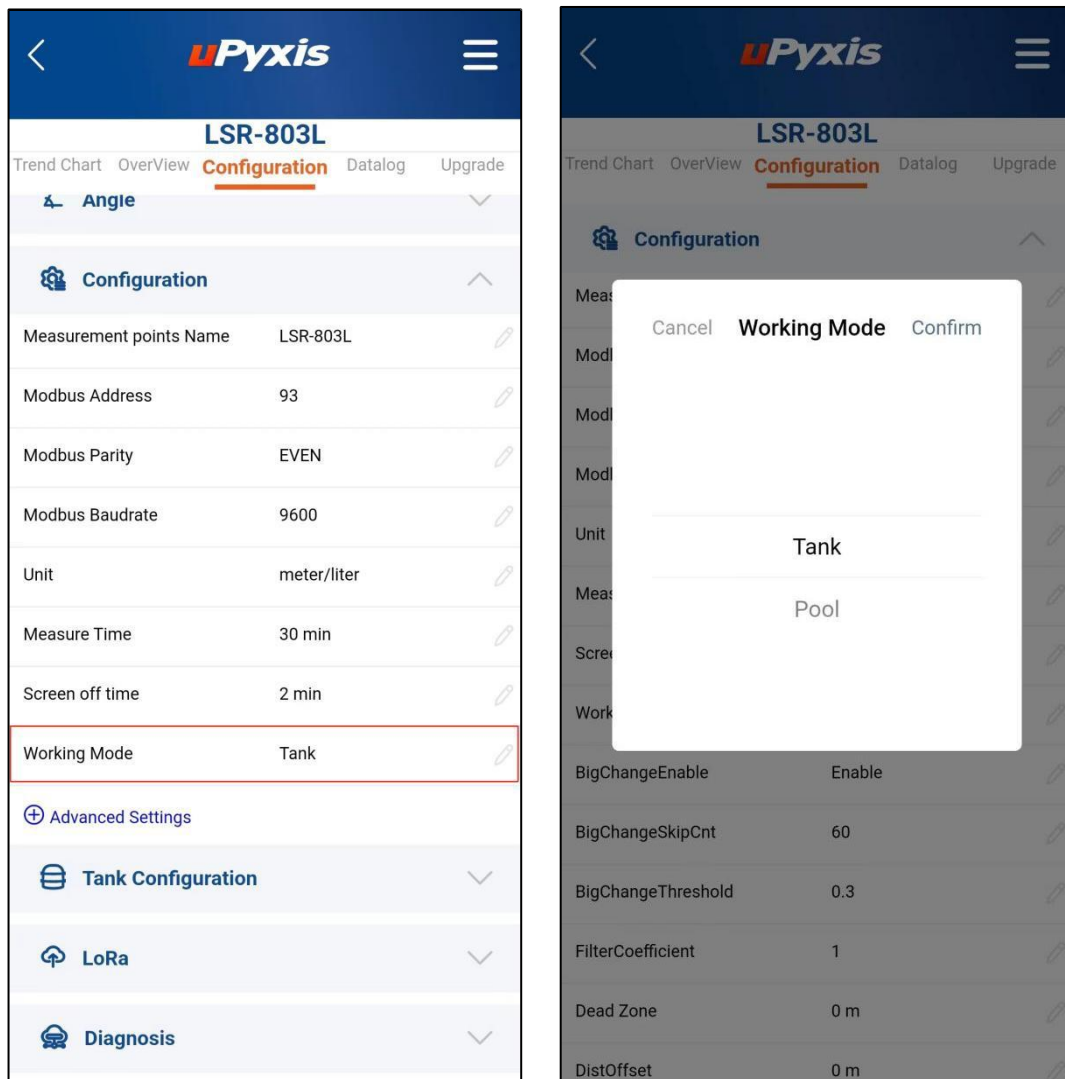

## 2. Measurement Parameters Configuration

### 2.1 Dead Zone Settings (Contact and Non-Contact)

The Pyxis radar level sensors have **ONE** dead zone parameter. The default dead zone of LSR-803(L) and LSR-801(L) is 2 inches. For contact installations (threaded into top of tank) if the distance between the sensor and the liquid interface is less than 2 inches, the radar level sensor will not be able to make a measurement. For non-contact measurement (i.e. above the tank itself), the dead zone can be adjusted to a value greater than the distance between the level sensor and the top surface of the tank. This prevents the measurement from being disturbed by tank surface.

**\*IMPORTANT NOTE\*** *Non-contact applications work through plastic or fiberglass only. NOT THROUGH METAL)*

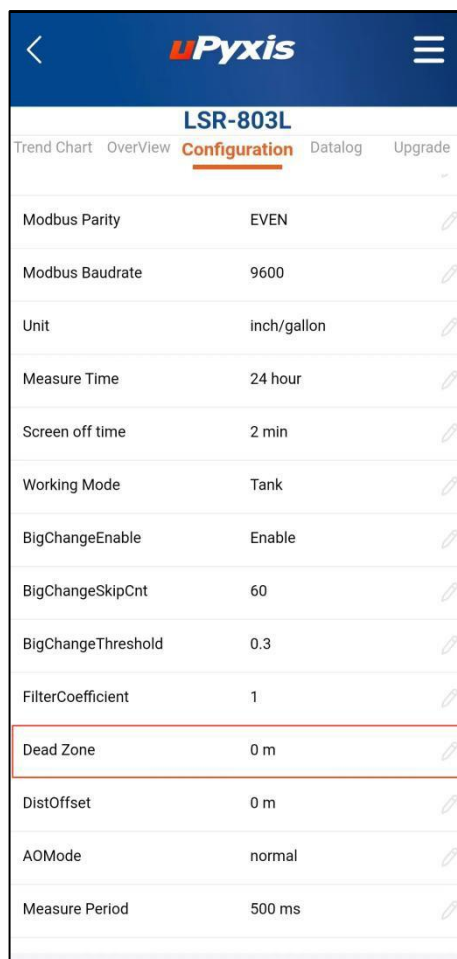

The screenshot shows the configuration interface for an LSR-803L sensor. The title bar includes the Pyxis logo and navigation icons. Below the title, there are tabs for Trend Chart, OverView, Configuration (selected), Datalog, and Upgrade. The main content area is a list of configuration parameters, each with a name, a value, and an edit icon.

LSR-803L				
Trend Chart	OverView	Configuration	Datalog	Upgrade
Modbus Parity	EVEN			
Modbus Baudrate	9600			
Unit	inch/gallon			
Measure Time	24 hour			
Screen off time	2 min			
Working Mode	Tank			
BigChangeEnable	Enable			
BigChangeSkipCnt	60			
BigChangeThreshold	0.3			
FilterCoefficient	1			
Dead Zone	0 m			
DistOffset	0 m			
AOMode	normal			
Measure Period	500 ms			

## Application Case 2







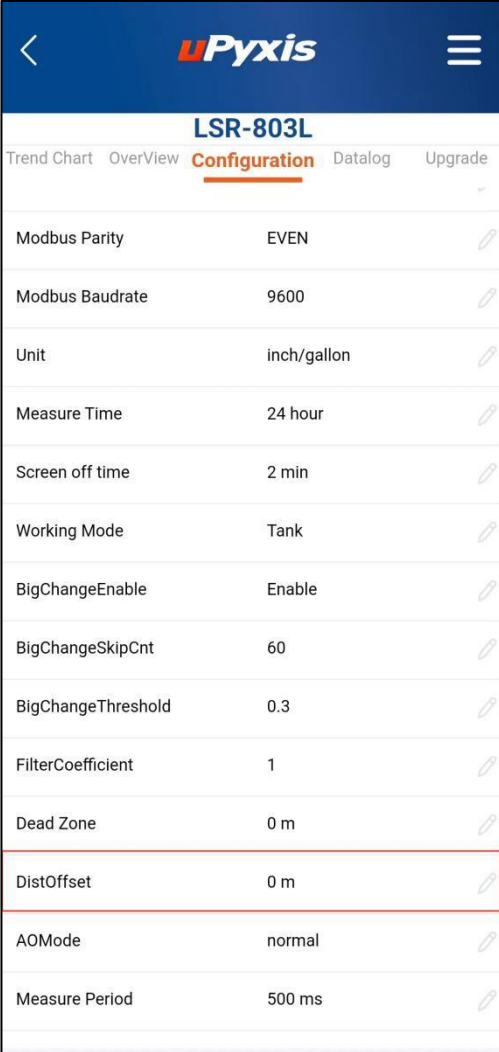







<b>Application Site</b>	USA – Beverage Manufacturer
<b>Device Model</b>	LSR-803L
<b>Power Supply</b>	Battery
<b>Communication</b>	LoRa
<b>Working Mode</b>	Interval measurement - 24 hours
<b>Request</b>	LSR-803L suspended above chemical tank, about 12 inches away from the tank. The reflected signal from the top surface of the tank may interfere with the reflected signal from the chemical inside the tank.
<b>Solution</b>	The dead zone of LSR-803L is set to 15 inches via uPyxis App, all reflected signals within 15 inches will be ignored, thus only the reflected signal from chemical will be accounted for measurement.
<b>Pictures</b>	

## 2.2 Distance Offset Settings

This is a calibration parameter that corrects the measured value. For example, when the parameter is set to 0.1 m, the distance value measured by the radar level sensor will be subtracted by 0.1 m. This parameter is usually used for non-contact measurement applications, where the radar wave passes through a container of a certain thickness. Due to the different dielectric constants, the propagation speed of the radar wave in the container medium is different from that in the air, which leads to a certain deviation in the calculated measurement distance. The deviation can be ignored safely if the thickness is small. However, if the deviation cannot be ignored, the measured value can be corrected by specifying a distance offset parameter.



The screenshot shows the configuration interface for the LSR-803L device. The 'Configuration' tab is selected, and a list of parameters is displayed. The 'DistOffset' parameter is highlighted with a red border.

LSR-803L				
Trend Chart	OverView	<b>Configuration</b>	Datalog	Upgrade
Modbus Parity	EVEN			
Modbus Baudrate	9600			
Unit	inch/gallon			
Measure Time	24 hour			
Screen off time	2 min			
Working Mode	Tank			
BigChangeEnable	Enable			
BigChangeSkipCnt	60			
BigChangeThreshold	0.3			
FilterCoefficient	1			
Dead Zone	0 m			
<b>DistOffset</b>	<b>0 m</b>			
AOMode	normal			
Measure Period	500 ms			

### Application Case 3

<b>Application Site</b>	LSR-803 was measured through fiber glass
<b>Device Model</b>	LSR-803
<b>Power supply</b>	Battery
<b>Communication</b>	LoRa
<b>Working Mode</b>	Continuous measurement
<b>Request</b>	LSR-803 measures level through a 15 mm thick fiber glass plate, increasing the measurement distance by 20 mm by penetrating the fiberglass.
<b>Solution</b>	Set distance offset value to 0.02m via uPyxis App, the measurement distance value is now reduced by 20mm, it is consistent with the actual value.
<b>Pictures</b>	

### 2.3 Interference Signal Blocking (Big Change Enable Feature)

This feature is used to block interfering signals that may be received by the radar level sensor. It requires 2 parameters, the measurement difference threshold, and the number of measurements threshold. For example, if you use the uPyxis App to set the measurement difference threshold to 0.05 meters and the number of measurements threshold to 60, the radar level sensor will ignore the current measurement if the difference between the current measurement and the last measurement is more than 5 centimeters but will use the last measurement if the difference between the 60 consecutive measurements and the last measurement is more than 5 centimeters.

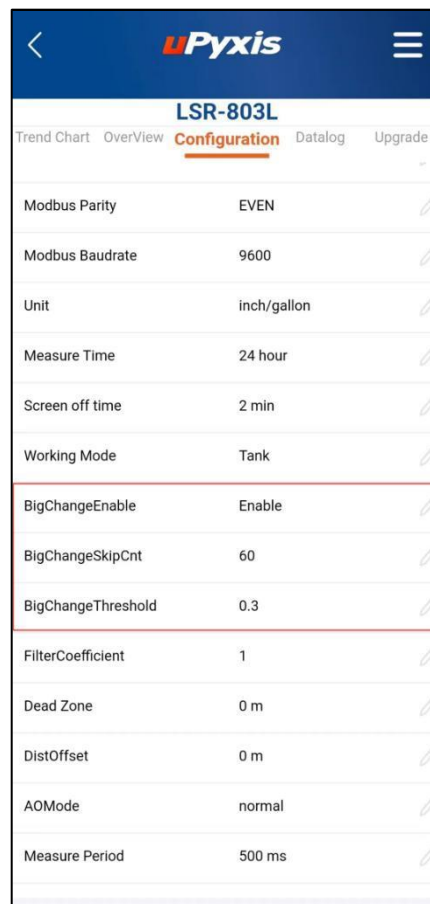

LSR-803L				
Trend Chart	OverView	<b>Configuration</b>	Datalog	Upgrade
Modbus Parity	EVEN			
Modbus Baudrate	9600			
Unit	inch/gallon			
Measure Time	24 hour			
Screen off time	2 min			
Working Mode	Tank			
BigChangeEnable	Enable			
BigChangeSkipCnt	60			
BigChangeThreshold	0.3			
FilterCoefficient	1			
Dead Zone	0 m			
DistOffset	0 m			
AOMode	normal			
Measure Period	500 ms			

#### Application Case 4

<b>Application Site</b>	Asia Pacific Sewage Treatment Plant
<b>Device Model</b>	LSR-801
<b>Power Supply</b>	24VDC
<b>Communication</b>	4-20mA
<b>Working Mode</b>	Continuous measurement
<b>Request</b>	The measured distance suddenly becomes fluctuated, user not happy.
<b>Solution</b>	uPyxis App sets measurement difference threshold to 2cm and number of measurements to 30. The measure results are stable since then.

## 2.4 Installation Angle Verification with uPyxis

For optimal radar level measurement, the radar waves need to be directed perpendicularly to the liquid surface. To determine if the sensor is perpendicular uPyxis App provides a utility to display the installation angle of the radar level sensor in real-time, allowing the user to adjust the installation angle to make it parallel to the horizontal plane. The radar level sensor can measure reliably if the installation angle is less than 3 degrees.

**\*NOTE\***: Picture shows the current tilt angle but not the direction of the tilt.

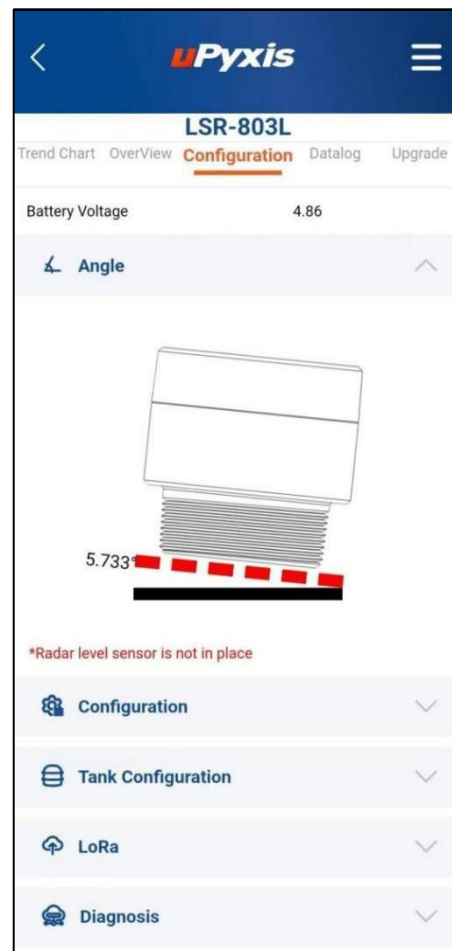
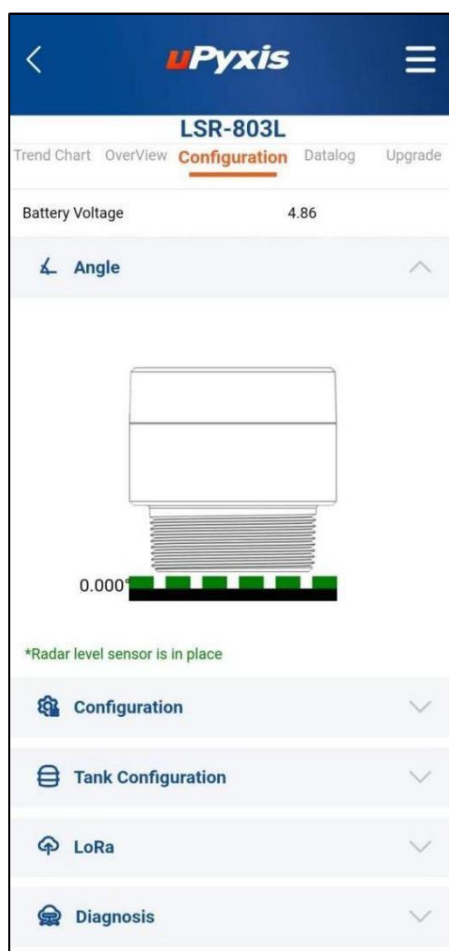

## 2.5 Use of VAPOR-BARRIER Well Insert Adapter for Amines/Ammonia

The Pyxis LSR Series radar level sensor body and transducer are composed of two plastic materials of construction which include **Polycarbonate (PC)** and **Polybutylene Terephthalate (PBT)**. While these materials of construction are highly resistant to a wide variety of industrial chemicals, they are not resistant to highly volatile Neutralizing Amines or Ammonia. For application use of the LSR-series of level sensors in Amine or Ammonia based chemistries, or other incompatible chemistries, Pyxis has developed the **LSR-MB-A001** (P/N: 21290) Well Insert Vapor Barrier. This item is offered in 2-inch MNPT threading and is composed of **Polyvinylidene Fluoride (PVDF)** and is sold separately as an optional accessory. PVDF is a highly non-reactive thermoplastic fluoropolymer and is a specialty plastic used in applications requiring resistance to solvents, acids, and hydrocarbons, allowing the LSR-Series to safely be used in non-compatible chemical tank level measurement applications.

To facilitate its use, simply thread the LSR-MB-A001 well insert vapor barrier into the tank bung-hole port and then thread the LSR Series radar sensor into the well insert barrier.

**\*IMPORTANT NOTE\*** The well thickness of this accessory is 4mm PVDF and may require minor adjustment to the **Distance Offset** settings within uPyxis.

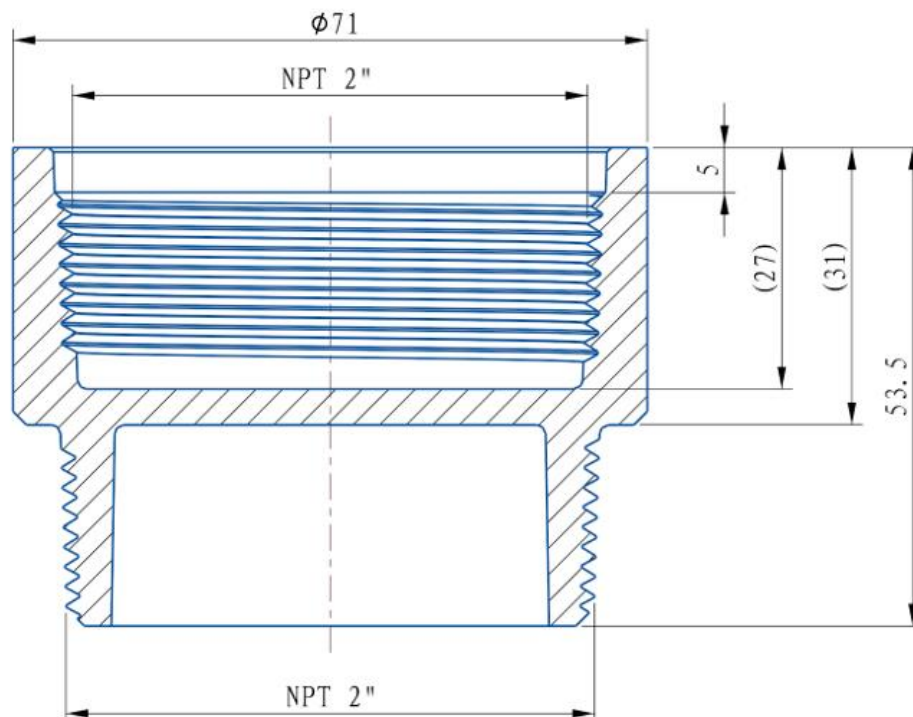

**Figure A** - LSR-MA-A001 Well Insert Vapor Barrier for Amine/Ammonia Tank Use

## 2.6 Diagnosis Parameter

The uPyxis App when connected to the radar level sensor offers a **Diagnosis Interface** providing the user with the measured level value, 4-20 mA value, SNR value (radar signal intensity) and Error code. The SNR value indicates the signal intensity measured by the radar, which can be used during installation and debugging.

Model	SNR		
	Low	Medium	High
LSR 801/L	<20	20-40	>40
LSR 803/L	<15	15-30	>30

If the SNR value is in the High range that means the signal is good. Please check the following items if the SNR value is in Low range:

1. Check if the installation angle is too great (>3 Degrees)
2. Check if the level sensor is close to the container or pool wall. Pyxis recommends a distance >20cm between the wall and the sensor.
3. Check if there are obstacles between the radar level sensor and the liquid.

**\*IMPORTANT NOTE\*** The radar level sensor is still able to measure properly if the SNR is greater than 10 for LSR-803(L) or is greater than 4 for LSR-801(L). LSR-801(L) cannot measure properly if its SNR is less than 4, LSR-803(L) cannot measure properly if its SNR is less than 10.

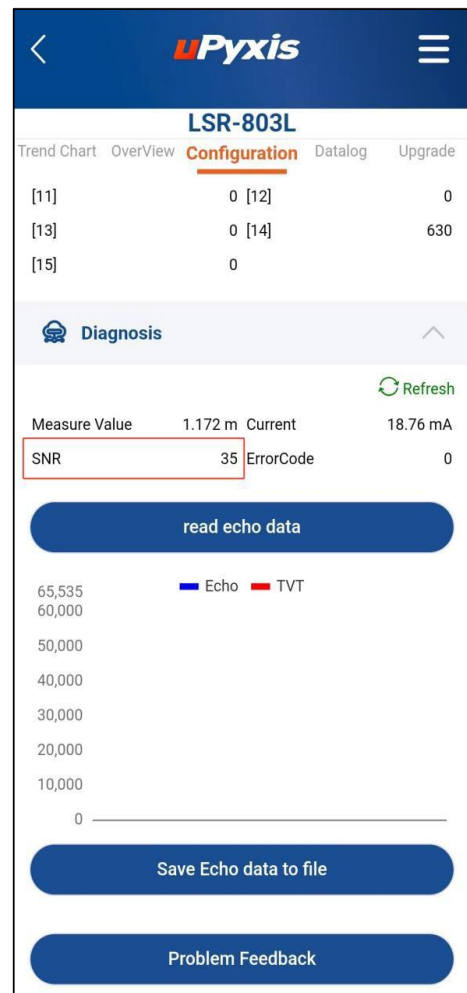

### 3. Communication Parameters Setting

#### 3.1 RS-485 Parameters Setting

Use the uPyxis App to set the radar level sensor RS-485 communication parameters, Modbus Address, Parity, and Baud rate.

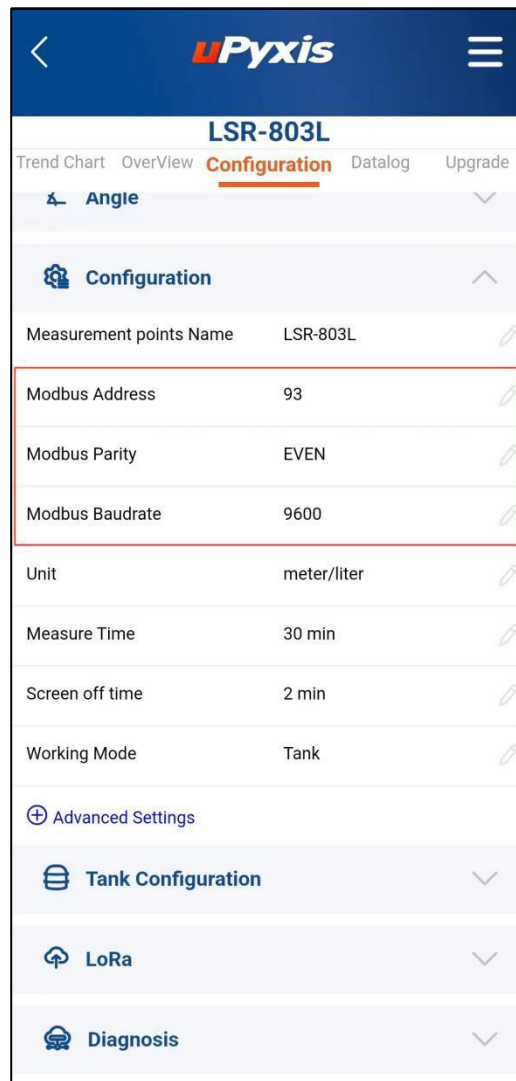

## 3.2 LoRa Parameters

Use the uPyxis App to set LoRa communication parameters. The following are import LoRa parameters.

**Channel:** Refers to the communication frequency, select the country according to the actual use location, and select the corresponding channel. If there are multiple groups of LoRa communication equipment on the site, please set each group as a different channel to avoid data interference.

**Spreading Factor:** The spreading factor refers to the number of symbols sent by each information bit. The parameter range is 9-12. If the spreading factor selected is 9, the transmission rate is fast, but the transmission distance is close. By setting the spreading factor to 12, the transmission rate is slow, and the transmission distance is extended. The user should set according to their actual application needs. The default spreading factor is 9. Always set the spreading factor to a larger value when long distance (e.g., over 1 mile) communication is required.

**Upload Period:** Refers to the period of data uploaded by the LoRa device. In the continuous measurement mode, the data is uploaded according to the upload period settings, and in interval measurement mode, data is uploaded every time a measurement is made.

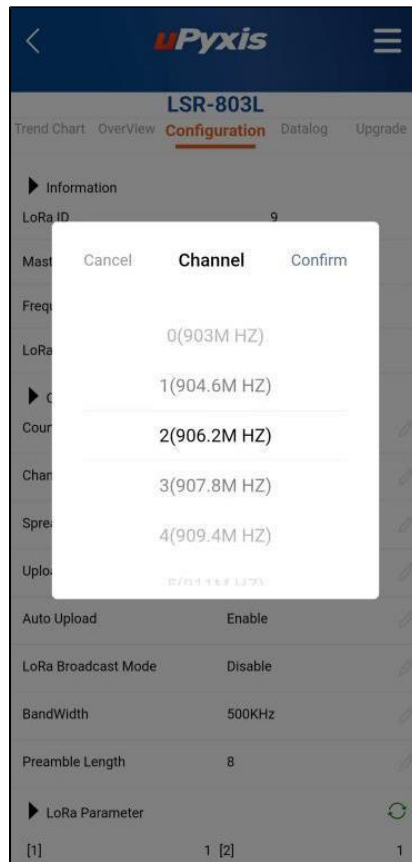
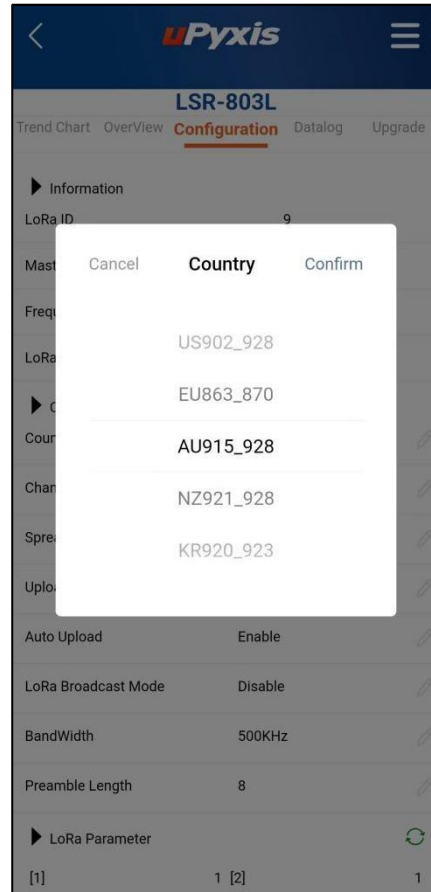
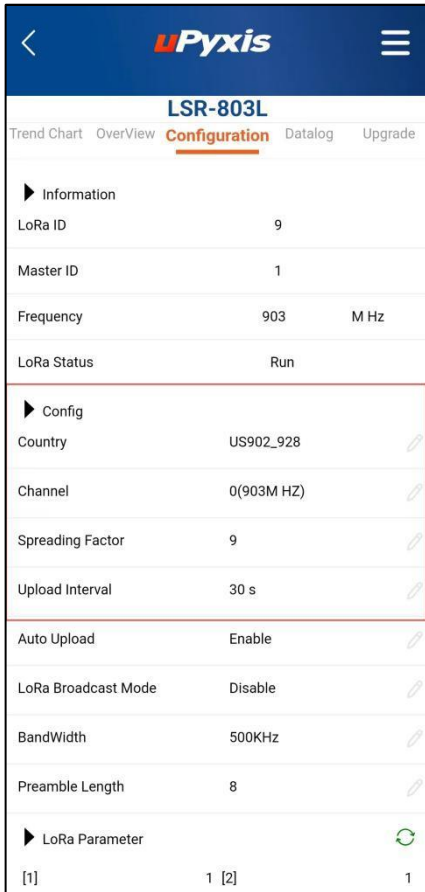

## 4. Firmware Upgrade

Use uPyxis App allows users to check, download and upgrade the radar level sensor to latest available firmware.

**\*NOTE\*** The level sensor will automatically restart after upgrading.

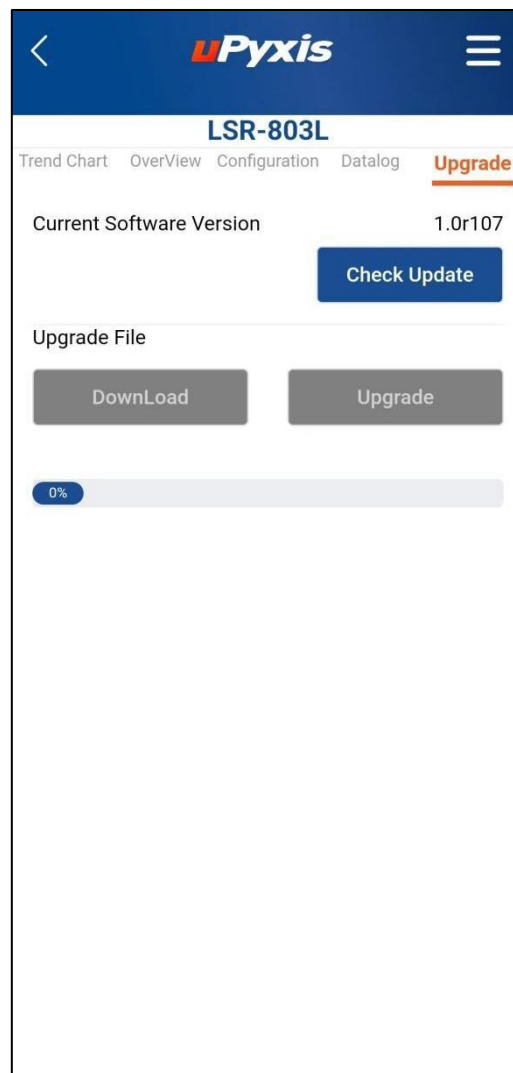

## 5. Data Log & Download for LSR-803(L) Only

The LSR-803(L) sensors have data logging capability. Use the uPyxis App to read the level data log from the radar level sensor. This data can be exported to csv file and emailed from the uPyxis App directly to the user.

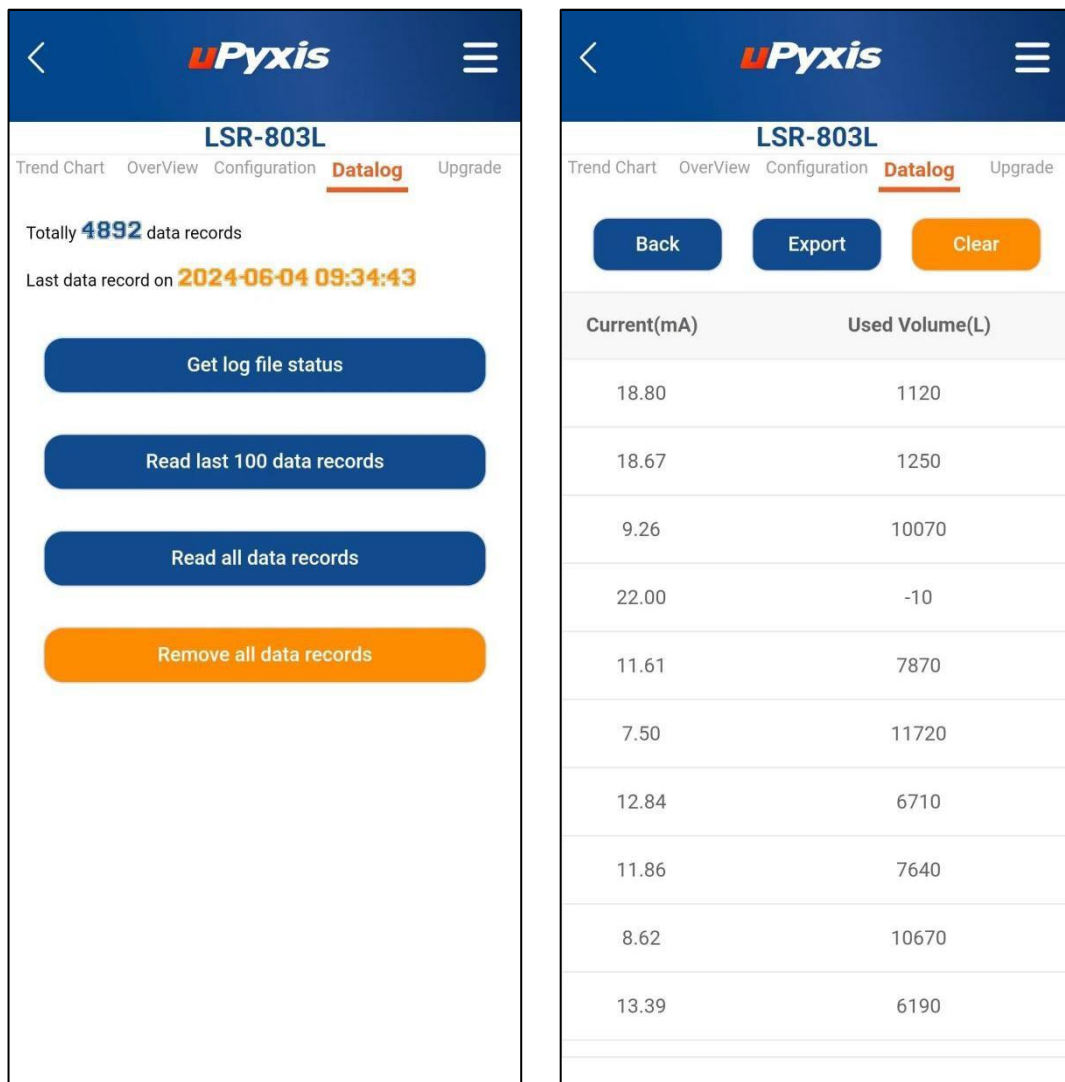

The left screenshot shows the uPyxis app interface for LSR-803L. The 'Datalog' tab is selected. It displays 'Totally 4892 data records' and 'Last data record on 2024-06-04 09:34:43'. Below this are four buttons: 'Get log file status', 'Read last 100 data records', 'Read all data records', and 'Remove all data records'.

The right screenshot shows the uPyxis app interface for LSR-803L. The 'Datalog' tab is selected. It displays a table with two columns: 'Current(mA)' and 'Used Volume(L)'. The table contains 10 rows of data records.

Current(mA)	Used Volume(L)
18.80	1120
18.67	1250
9.26	10070
22.00	-10
11.61	7870
7.50	11720
12.84	6710
11.86	7640
8.62	10670
13.39	6190