



LG-50 LoRa Transmitter

LoRa Transmitter for LSR-Series Rada Level Sensors



Pyxis Lab® Inc.
21242 Spell Circle
Tomball, TX 77375
www.pyxis-lab.com

**OPERATION
MANUAL**



The information contained in this manual may be confidential and proprietary and is the property of Pyxis Lab, Inc. Information disclosed herein shall not be used to manufacture, construct, or otherwise reproduce the goods described. The information disclosed herein shall not be disclosed to others or made public in any manner without the express written consent of Pyxis Lab, Inc.

Limited Warranty

Pyxis Lab warrants its products for defects in materials and workmanship. Pyxis Lab will, at its option, repair or replace instrument components that prove to be defective with new or remanufactured components (i.e., equivalent to new). The warranty set forth is exclusive and no other warranty, whether written or oral, is expressed or implied.

Warranty Term

The Pyxis warranty term is thirteen (13) months ex-works. In no event shall the standard limited warranty coverage extend beyond thirteen (13) months from the original shipment date.

Warranty Service

Damaged or dysfunctional instruments may be returned to Pyxis for repair or replacement. In some instances, replacement instruments may be available for short duration loan or lease.

Pyxis warrants that any labor services provided shall conform to the reasonable standards of technical competency and performance effective at the time of delivery. All service interventions are to be reviewed and authorized as correct and complete at the completion of the service by customer representative or personnel. Pyxis warrants these services for 30 days after the authorization and will correct any qualifying deficiency in labor provided that the labor service deficiency is exactly related to the originating event. No other remedy, other than the provision of labor services, may be applicable.

Repair components (parts and materials), but not consumables, provided during a repair, or purchased individually, are warranted for 90 days ex-works for materials and workmanship. In no event will the incorporation of a warranted repair component into an instrument extend the whole instrument's warranty beyond its original term.

Warranty Shipping

A Repair Material Authorization Number (RMA) must be obtained from Pyxis Technical Support before any product can be returned to the factory. Pyxis will pay freight charges to ship replacement or repaired products back to the customer. The customer shall pay freight charges for returning products to Pyxis. To receive an RMA, you can generate a request on our website at <https://www.pyxis-lab.com/request-return-or-repair/>

Pyxis Technical Support

You can contact Pyxis Technical Support at 1-866-203-8397 or service@pyxis-lab.com

Table of Contents

1. Introduction.....	4
2. Specifications.....	4
3. Unpacking Instrument.....	5
3.1 Standard Accessories	5
3.2 Optional / Replacement Accessories	5
4. Installation.....	6
4.1 Connecting to Power.....	6
4.2 Connecting to Devices.....	6
4.2.1 Overall Wiring Diagram.....	7
4.2.2 Device Connected via Modbus.....	7
4.2.3 Device Connected via 4-20mA	8
4.2.4 Device Connected via Digital Input:	9
4.3 Dimension	10
4.4 Installation Guide.....	10
4.5 Wall Mounting Bracket Installation	10
5. Device Overview.....	12
5.1 LED Indicators	12
6. Setup with uPyxis 2.0 Mobile App.....	13
6.1 Download App.....	13
6.2 Connecting to LG-50 Device.....	13
6.3 Parameters Configuration.....	14
7. Regulatory Approval.....	17
Contact Us.....	17

1. Introduction

The Pyxis LG-50 is a unique wireless transmitter designed to collect local signals from Pyxis sensors and third-party devices as direct terminal (flying lead) wiring via RS485 Modbus, 4-20mA input and digital input (i.e. dry contact, NPN or PNP signal inputs), and send them via Long Range Radio (LoRa) to a remote device such as Pyxis 4G Gateway, Pyxis LG-100 or LG-200 LoRa receivers. The Pyxis LG-50 is also capable of passing through a 4-20mA signal to a local controller. The LG-50 can be configured wirelessly via the Pyxis uPyxis® App for rapid integration and deployment in the field. Powered by a 24 VDC external power supply, the LG-50 is ideally suited for use with LG-100, LG-200 or Pyxis 4G Gateway to offer you a versatile and cost-effective IoT solution.

2. Specifications

Specification	LG-50
Part Number (P/N)	24817
Power Supply	24 VDC, 1W Max (no probe included)
Bluetooth® Connectivity	Bluetooth 5.0® 4.1, 32 ft. (10 Meters) Line of Sight for use with uPyxis®
Radio Output	Long Range Radio (LoRa)
Wired Input	1x 4-20mA / RS-485 MODBUS / PNP or NPN digital input
Output Cable	Waterproof 7-Pin (10ft / 3m) Cable with Adapter & Flying Lead
Extension Cable	Waterproof Extension Cables Sold Separately
Installation	Wall Mounting Bracket
Dimension	Height: 4.67 inch (118.6 mm); Length: 5.71 inch (145 mm); Width: 3.15 inch (80 mm)
Enclosure Material	Polybutylene Terephthalate (PBT), Polycarbonate (PC)
Ambient Temperature	5 - 122 °F (-15 - 50 °C)
Storage Temperature	-4 - 140 °F (-20 - 60 °C)
Pressure	-29 - 58 PSI (-0.2 - 0.4 MPa)
Enclosure Rating	IP66
Regulation	FCC / CE / UKCA / RoHS
Wireless Certified FCC ID	2BAJ2-LSR

**With Pyxis' continuous improvement policy, this specification is subject to change without notice.*

3. Unpacking Instrument

Remove the instrument and find the standard accessories from the shipping container as listed below. Inspect each item for any damage that may have occurred during shipping. Verify that all accessory items are included. If any item is missing or damaged, please contact Pyxis Lab Customer Service at service@pyxis-lab.com or by phone at 1-866-203-8397.

3.1 Standard Accessories

The LG-50 LoRa transmitter is delivered with the items outlined below.

LG-50 LoRa transmitter (P/N 24817)

Flying Lead cable (10ft /3m)

MA-L10 Waterproof 7-Pin Cable with Adapter

3.2 Optional / Replacement Accessories

The following optional or replacement accessories are available for use with LG-50 LoRa transmitter and are sold separately.

Ordering Information

P/N

LG-50 *(Includes 10-foot Flying Lead Cable w/Adapter)*

24817

Optional Accessories

P/N

LG-MB-W002 *(LG Series – Wall Mounting Bracket Kit Wall Mounting Installs)*

26118

MA-L10 *(Replacement Waterproof 10' Flying Lead Cable w/7Pin Waterproof Adapter)*

MA-L10

MA-AC-7US *(110VAC-24VDC Power Supply Adapter – 7Pin Waterproof – USA Plug)*

26398

MA-AC-7EU *(230VAC-24VDC Power Supply Adapter – 7Pin Waterproof – EU/Din Plug)*

28787

25' Waterproof Extension Cable *(7Pin Waterproof Adapters)*

MA-L25

50' Waterproof Extension Cable *(7Pin Waterproof Adapters)*

MA-L50

100' Waterproof Extension Cable *(7Pin Waterproof Adapters)*

MA-L100

4. Installation

4.1 Connecting to Power

The LG-50 LoRa transmitter is powered by 24V DC power supply. The maximum power consumption of LG-50 is 1.0W. Make sure the output from the power supply is rated for 22-26 VDC. Depending on devices being connected to LG-50, the total power required may vary. Please refer to the following table to choose an appropriate power supply for your LG-50 setup.

Device	LG-50 Power Consumption	Device Power Consumption	Total Power Demanding
Pyxis device via Modbus	1.0 Watt	2.0 Watt	22-26 VDC @ 200mA
Third-party 4-20mA device	1.0 Watt	3.0 Watt	22-26 VDC @ 300mA
Third-party digital input device	1.0 Watt	3.0 Watt	22-26 VDC @ 300mA

NOTE Pyxis recommends powering off the controller when connecting the LG-50 and the controller with MA-L10 cable. Follow the wiring table below to connect LG-50 to a controller or receiving device.

Wire Color	Designation
Red	24V+
Black	24V power ground
White	4-20 mA+
Green	4-20 mA-

4.2 Connecting to Devices

The LG-50 LoRa transmitter supports the connection with all Pyxis probes with 7pin standard, 7pin waterproof and 8pin standard connectors. The LG-50 also supports the connection with third-party devices. For all device connections, user needs to open the device cover according to the instructions of the terminal block to land the flying lead wires of the connected device. Please refer to the table at the right side for terminal block wiring designation.

Wiring label	Designation
24V+	24V+ to device
GND	24V power ground
AIN	Analog input 4-20mA+
GND	Analog input 4-20mA-
485A	RS-485A
485B	RS-485B
DIN	Digital input
COM	Digital input common terminal

4.2.1 Overall Wiring Diagram

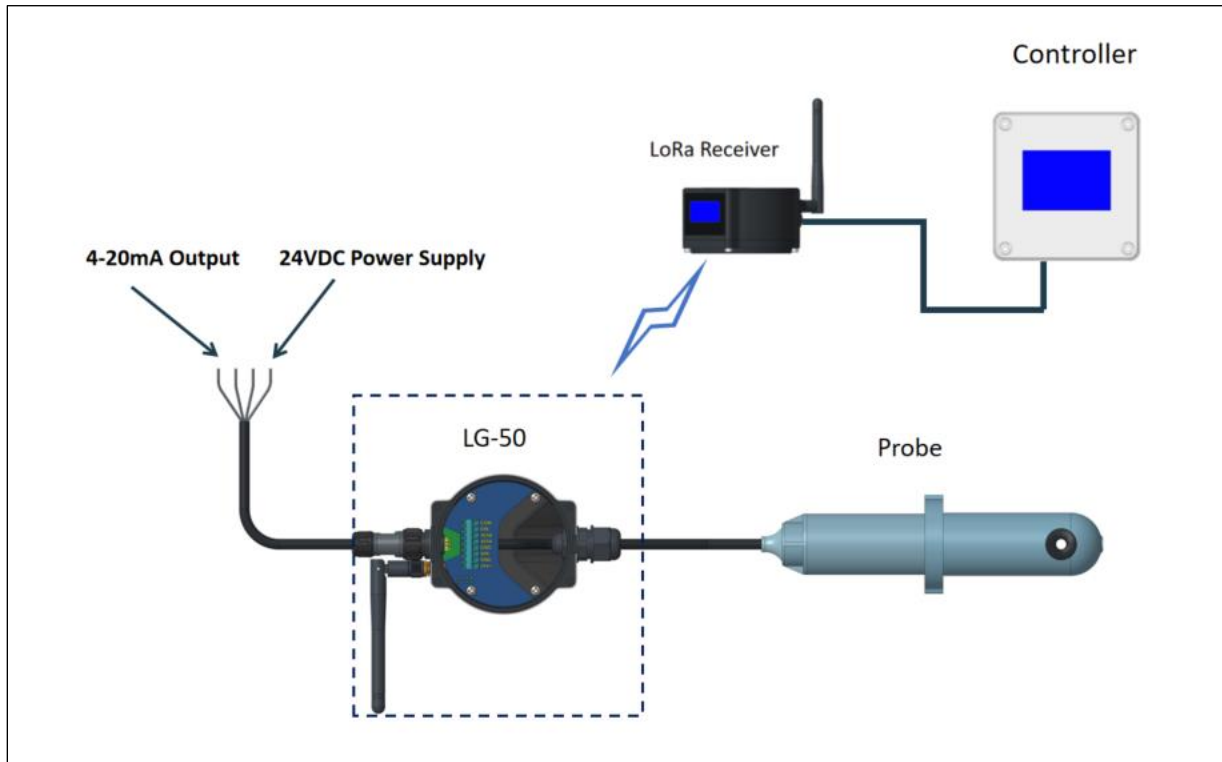

Fig 1. Wiring Diagram

4.2.2 Device Connected via Modbus

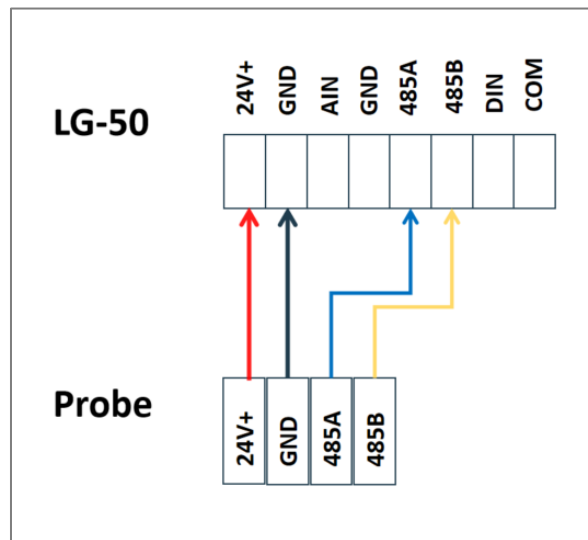

Fig 2. Wiring Diagram for Modbus device

4.2.3 Device Connected via 4-20mA

Two-Wire Loop-Powered Devices/Sensors:

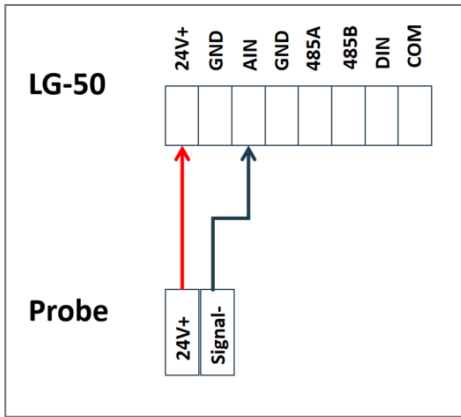

Fig 3. Wiring diagram for loop-powered 4-20mA

Two-Wire Externally-Powered Devices/Sensors:

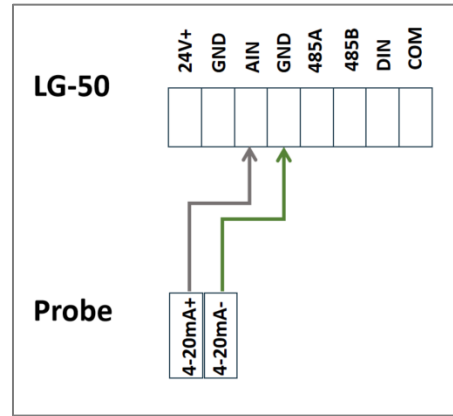

Fig 4. Wiring diagram for 4-20mA external power

Three-Wire Devices/Sensors:

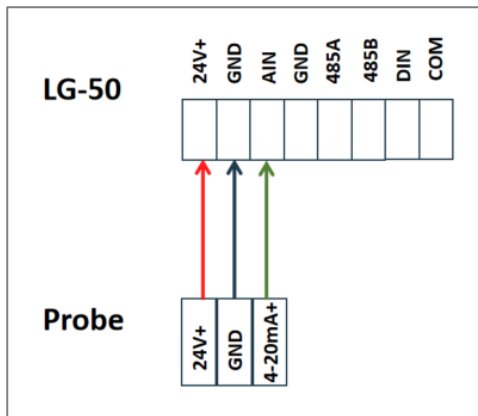

Fig 5. Wiring diagram for 3-wire 4-20mA

Four-wire Devices/Sensors:

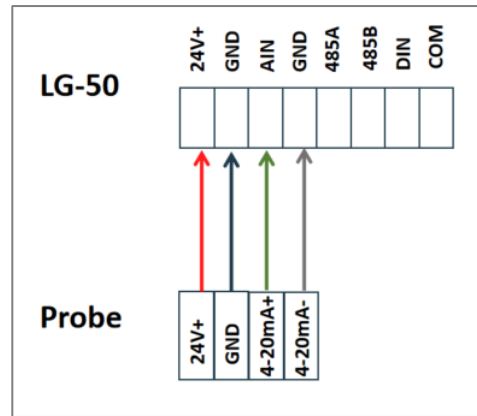

Fig 6. Wiring diagram for 4-wire 4-20mA

4.2.4 Device Connected via Digital Input:

NPN/ Dry Relay Type Devices:

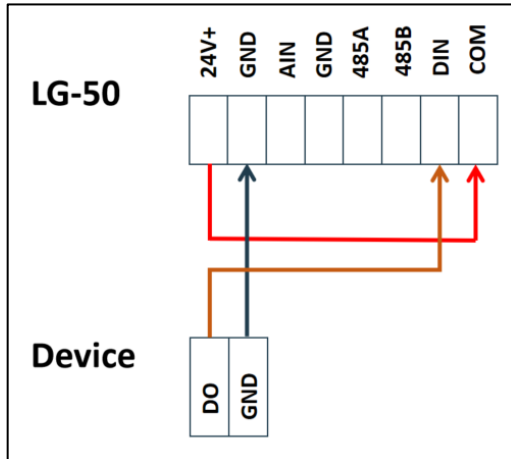

Fig 7. Wiring diagram for NPN/ Dry Relay

PNP/ Pulse Signal Type Devices:

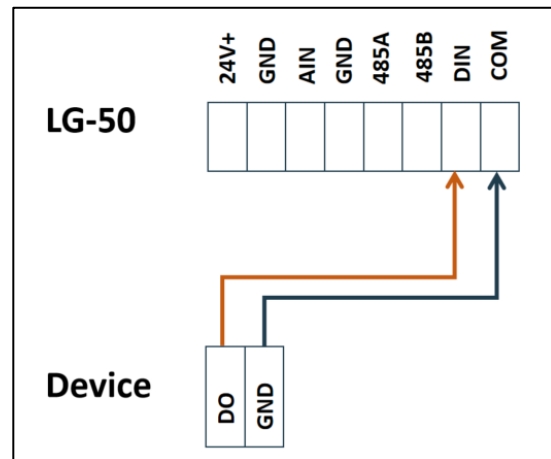

Fig 8. Wiring diagram for PNP input/ Pulse Signal

4.3 Dimension

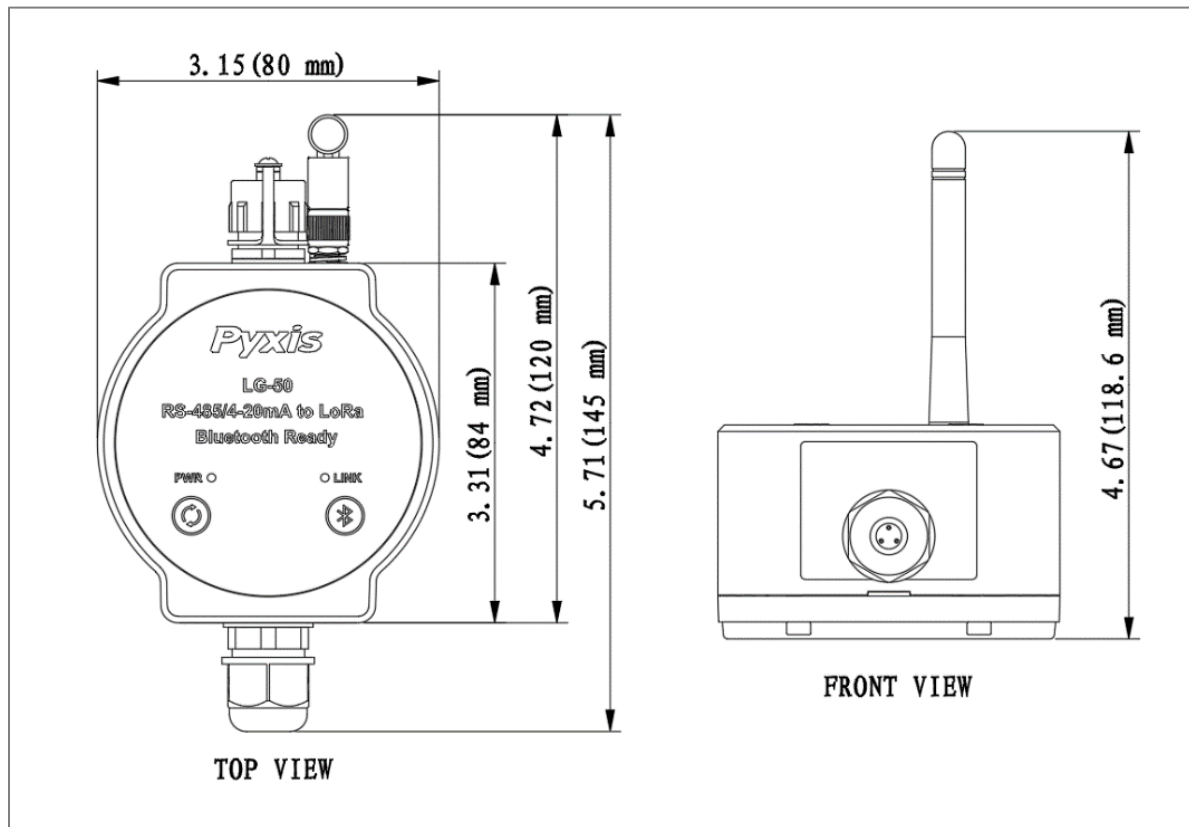

Fig 9. LG-50 Dimension, inch (mm)

4.4 Installation Guide

The following guidelines should be followed when installing the LG-50.

- When installing in an open area, the antenna of the LG-50 and the antenna of the LG-100 or LG-200 should be kept at the same height as much as possible.
- When the LG-50 is installed in an area with a lot of obstructions, it should be mounted as high as possible so that the antenna is at a high position to minimize interference with communications.

4.5 Wall Mounting Bracket Installation

The LG-MB-W002 wall mount bracket is available as optional accessories (sold separately) for wall mounting installation of the LG-50 LoRa transmitter. For the LSR Series Mounting Kit Installation Guide please contact service@pyxis-lab.com



Figure 10. LG-MB-W002 (P/N 26118) Wall Mounting Bracket for LG-50

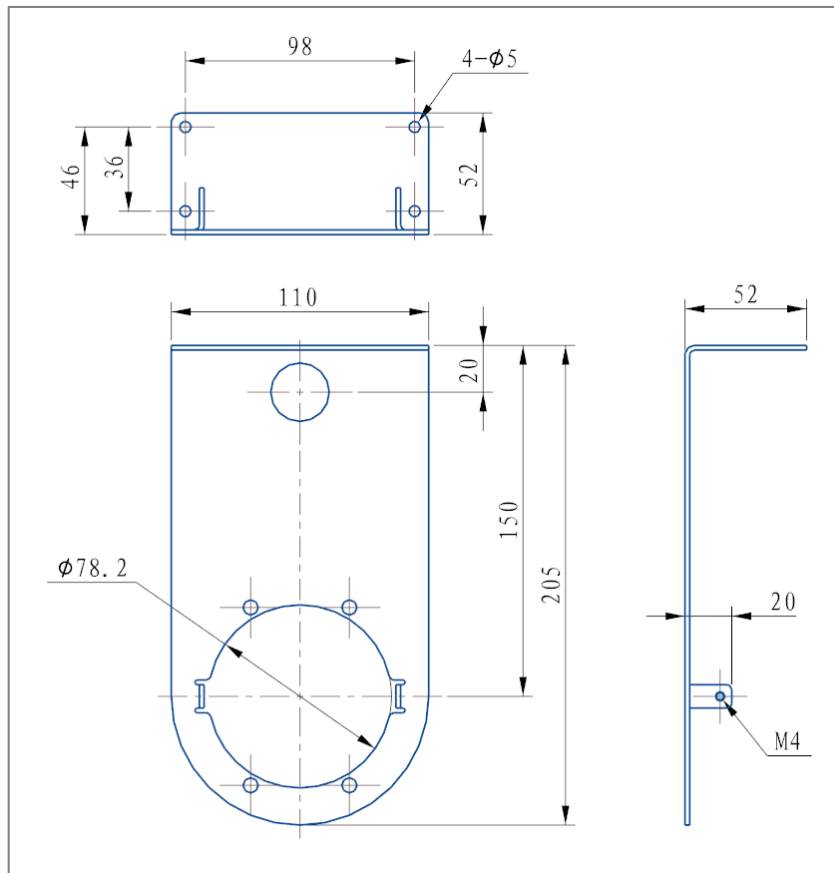

Figure 11. LG-MB-W002 Dimensions (mm)

5. Device Overview

5.1 LED Indicators

The LED indicators on the top of the device (Figure 12) are used to indicate device status and Bluetooth 5.0® connection status.

LED Status	ON	OFF
Green LED	Power Supply is ON and device is running	Power Supply is OFF
Blue LED	Bluetooth 5.0® is connected	Bluetooth 5.0® is disconnected

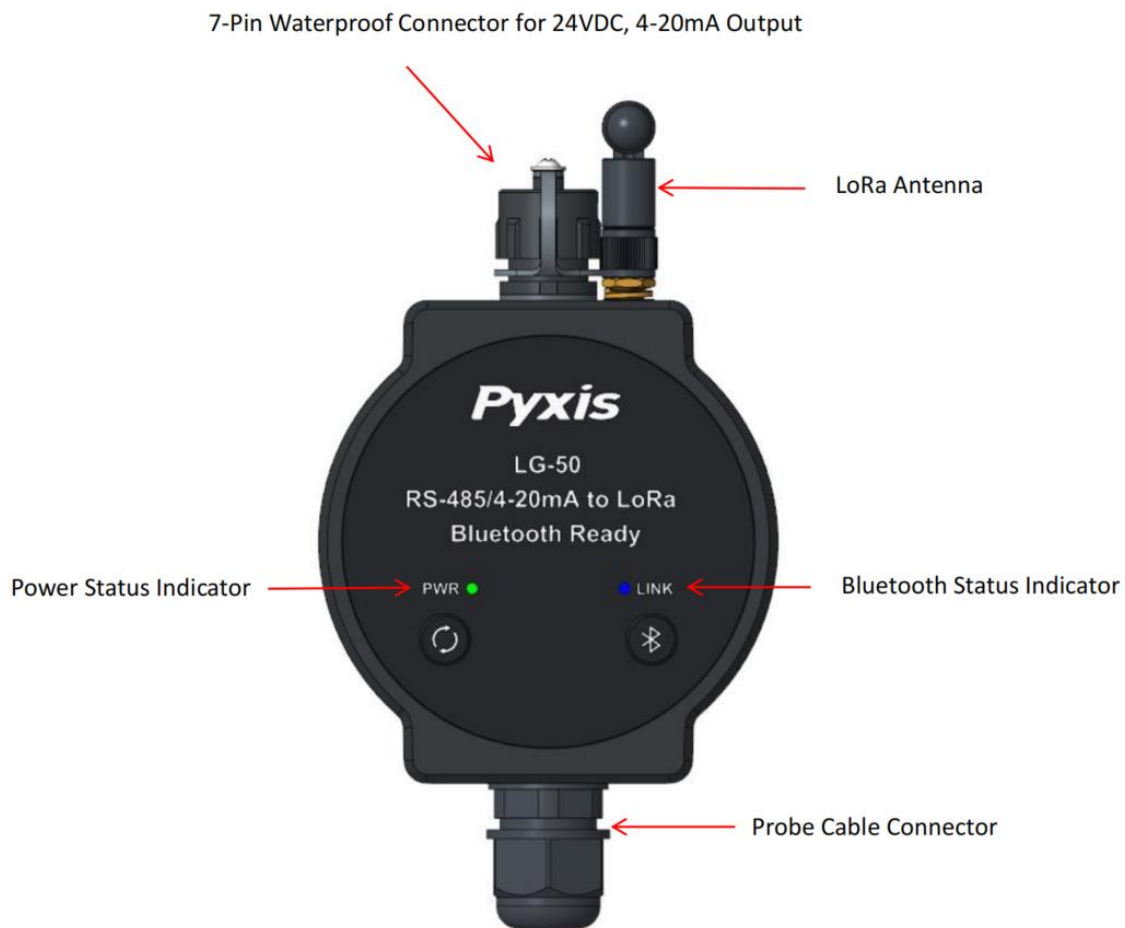
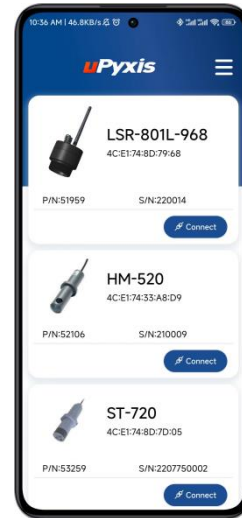

Figure 12. Power and Bluetooth LEDs

6. Setup with uPyxis 2.0 Mobile App

6.1 Download App

Download **uPyxis 2.0** Mobile APP from [App Store](#) or [Google Play](#).



6.2 Connecting to LG-50 Device

Turn on the Bluetooth 5.0® on in your mobile device.

NOTE Do not pair the phone's Bluetooth to LG-50 device, the uPyxis 2.0 App will do the pairing.

Open uPyxis 2.0 Mobile App. Click “Scan Bluetooth” button and the App will start to search for Pyxis devices. Click the Connect button under **LG-50** to connect to it.

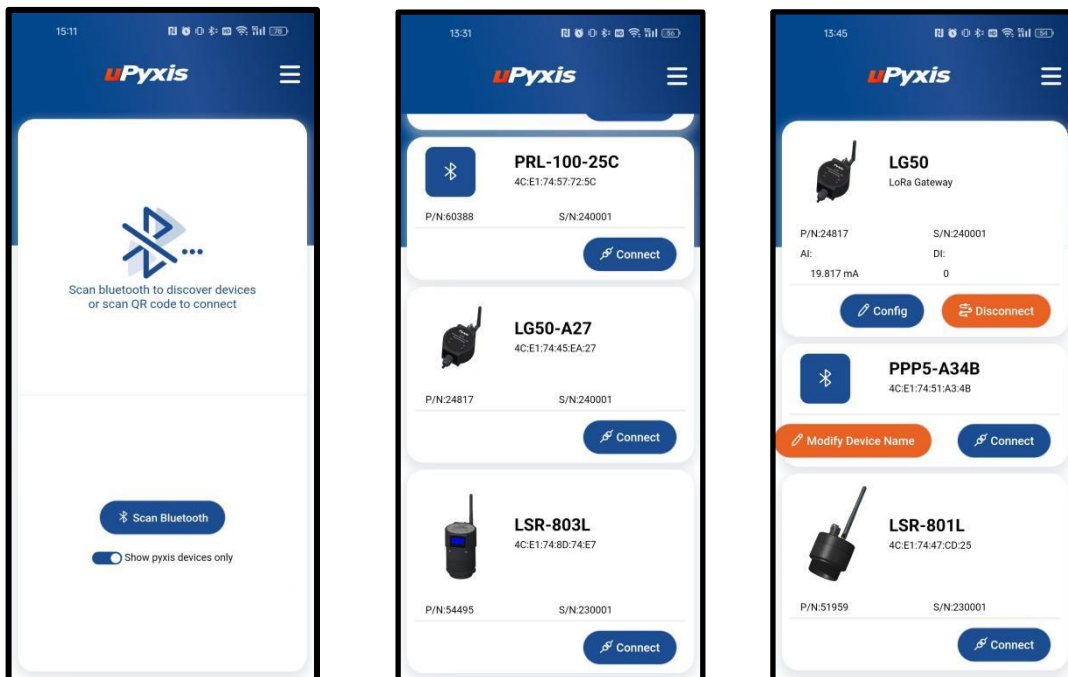

Figure 13. LG-50 Connection

6.3 Parameters Configuration

Once connected to LG-50, the uPyxis 2.0 App will display the **Trend Chart** page. The user can click on different menus to read the LG-50 device information or make changes to its settings as shown in Figure 14.

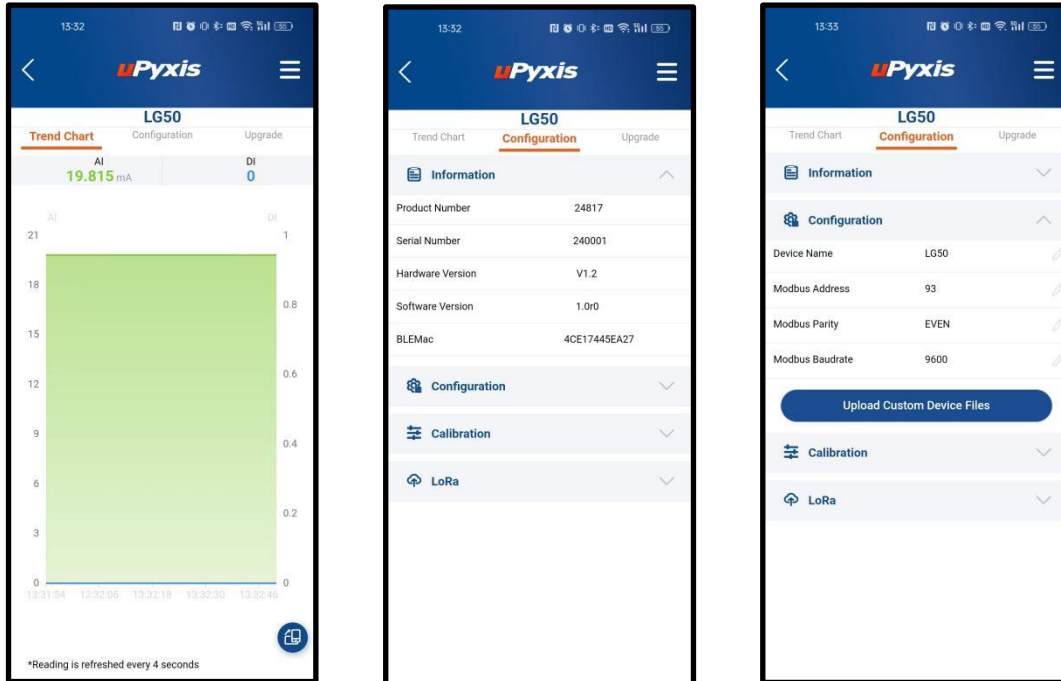
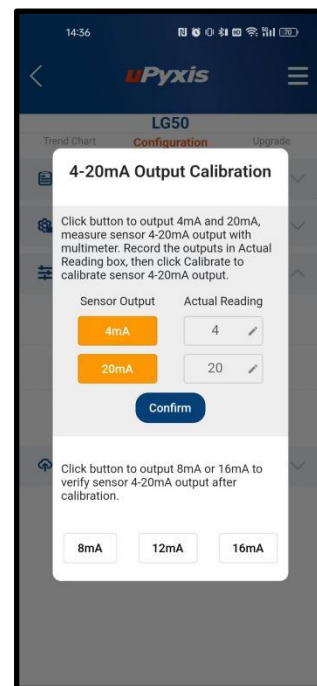
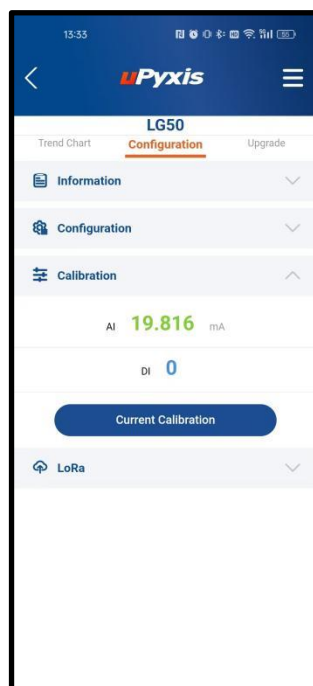
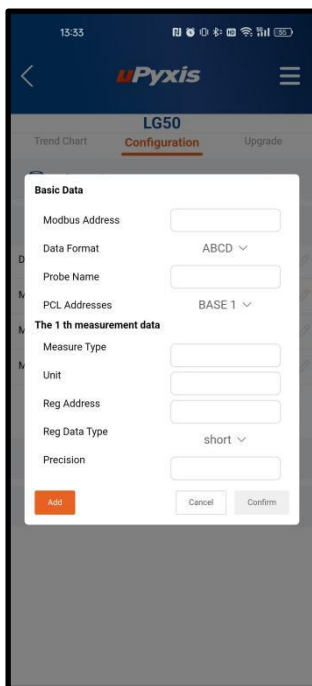

Figure 14. LG-50 Configurations

- Click the **"Information"** menu to display basic information of the LG-50 device, i.e., product number, serial number, hardware version number, software version number and Bluetooth MAC address.
- Click the **"Configuration"** menu to rename the device name and change its Modbus communication settings. Click **"Upload Custom Device Files"** to edit the RS485 communication parameters of the connected probe. When a third-party probe is connected, the LG-50 reads the device's readings and other information through the information in Device Files
- Click the **"Calibration"** menu to display 4-20mA current value and current calibration

- **Current Calibration:** The 4-20mA output of LG-50 has the function of calibration, select the channel to be calibrated, click on the 4mA output to measure the actual output current value and write it into the calibration block (e.g., 3.97mA), then click on the 20mA output, also measure the actual output value and write it into the calibration block (e.g., 19.95mA), and then click on Confirm, the current calibration is completed, and you can then click on the following 8mA, 12mA, 16mA to verify the effect after calibration

- Click the "LoRa" menu and three additional submenus under LoRa will be displayed: **Information**, **Config** and **LoRa Parameter**
 - **Information:** show the LoRa parameters.
 - **Config:** As shown in the figure, the parameters Country, Channel, SF, Bandwidth must be the same as the LoRa device to be connected, otherwise communication will not be possible. All LoRa devices have the same parameters when they are shipped from the factory, if there are more than one group of LoRa devices in the field, you need to set the channel of one group of LoRa devices to other parameters, to avoid interference in communication.
 - **LoRa Parameter:** LoRa Parameter does not need to be set, these parameters indicate the status of LoRa communication, if you encounter communication problems, you can contact service@pyxis-lab.com for support.



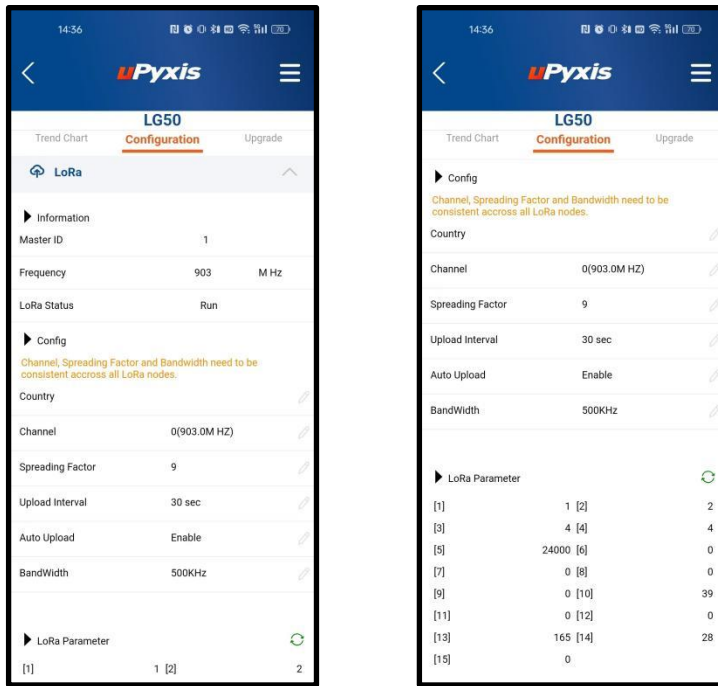

Figure 15. LG-50 Configuration Menu

7. Regulatory Approval

United States

The LG-50 has been tested and found to comply with the limits for a Class B digital device, pursuant to part 15 of the FCC Rules. These limits are designed to provide reasonable protection against harmful interference in a residential installation. This equipment generates, uses and can radiate radio frequency energy, and if not installed and used in accordance with the instructions, may cause harmful interference to radio communications. However, there is no guarantee that interference will not occur in an installation. If this equipment does cause harmful interference to radio or television reception, which can be determined by turning the equipment off and on, the user is encouraged to try to correct the interference by one or more of the following measures:

- Reorient or relocate the receiving antenna.
- Increase the separation between the equipment and transmitter.
- Connect the equipment into an outlet on a circuit different from that to which the transmitter is connected.
- Consult the dealer or an experienced radio/TV technician for help

Canada

This device complies with Industry Canada license exempt RSS standard(s). Operation is subject to the following two conditions: (1) this device may not cause interference, and (2) this device must accept any interference, including interference that may cause undesired operation of the device.

Le présent appareil est conforme aux CNR d'Industrie Canada applicables aux appareils radio exempts de licence. L'exploitation est autorisée aux deux conditions suivantes: (1) l'appareil ne doit pas produire de brouillage, et (2) l'utilisateur de l'appareil doit accepter tout brouillage radioélectrique subi, même si le brouillage est susceptible

Contact Us

Pyxis Lab, Inc.

21242 Spell Circle

Tomball, TX 77375 USA

www.pyxis-lab.com / service@pyxis-lab.com