

Pyxis[®]

LG-100 LoRa[™] Receiver & Converter

Ultra-Long Range LoRa[™] Reception & Conversion Device



Pyxis Lab[®] Inc.

21242 Spell Circle
Tomball, TX 77375
www.pyxis-lab.com

**OPERATION
MANUAL**



The information contained in this manual may be confidential and proprietary and is the property of Pyxis Lab, Inc. Information disclosed herein shall not be used to manufacture, construct, or otherwise reproduce the goods described. Information disclosed herein shall not be disclosed to others or made public in any manner without the express written consent of Pyxis Lab, Inc.

Limited Warranty

Pyxis Lab warrants its products for defects in materials and workmanship. Pyxis Lab will, at its option, repair or replace instrument components that prove to be defective with new or remanufactured components (i.e., equivalent to new). The warranty set forth is exclusive and no other warranty, whether written or oral, is expressed or implied.

Warranty Term

The Pyxis warranty term is thirteen (13) months ex-works. In no event shall the standard limited warranty coverage extend beyond thirteen (13) months from the original shipment date.

Warranty Service

Damaged or dysfunctional instruments may be returned to Pyxis for repair or replacement. In some instances, replacement instruments may be available for short duration loan or lease.

Pyxis warrants that any labor services provided shall conform to the reasonable standards of technical competency and performance effective at the time of delivery. All service interventions are to be reviewed and authorized as correct and complete at the completion of the service by customer representative or personnel. Pyxis warrants these services for 30 days after the authorization and will correct any qualifying deficiency in labor provided that the labor service deficiency is exactly related to the originating event. No other remedy, other than the provision of labor services, may be applicable.

Repair components (parts and materials), but not consumables, provided during a repair, or purchased individually, are warranted for 90 days ex-works for materials and workmanship. In no event will the incorporation of a warranted repair component into an instrument extend the whole instrument's warranty beyond its original term.

Warranty Shipping

A Repair Material Authorization Number (RMA) must be obtained from Pyxis Technical Support before any product can be returned to the factory. Pyxis will pay freight charges to ship replacement or repaired products back to the customer. The customer shall pay freight charges for returning products to Pyxis. To receive an RMA, you can generate a request on our website at <https://www.pyxis-lab.com/request-return-or-repair/>

Pyxis Technical Support

You can contact Pyxis Technical Support at 1-866-203-8397 or service@pyxis-lab.com

Table of Contents

1.	Introduction.....	4
2.	Specifications.....	4
3.	Unpacking Instrument.....	5
3.1	Standard Provided Accessories.....	5
3.2	Optional / Replacement Accessories	5
4	Installation.....	6
4.1	Power and Wiring	6
4.2	Dimensions.....	6
4.3	Installation Guide	7
4.4	Wall Mounting Bracket Installation	7
5	Instrument Overview	9
5.1	LED Indicators	9
5.2	Function Buttons.....	9
5.3	OLED Display Symbols & Definitions.....	10
6	Setup with uPyxis 2.0 Mobile App.....	14
6.1	Download the uPyxis 2.0 Mobile App	14
6.2	Connecting to uPyxis 2.0 Mobile App	14
6.3	Parameter Setting via uPyxis Mobile App.....	15
7.	Regulatory Approval.....	17
	Contact Us.....	17

1. Introduction

The Pyxis LG-100 is a LoRa enabled receiver device designed to capture data via LoRa (Long-Range Radio) communications and convert the received data into Modbus RS-485 or 4-20mA outputs for connection to multiple device formats. The LG-100 LoRa receiver has a 1.3-inch OLED display and 4 buttons for easy wireless configuration with the **uPyxis®** app for Mobile and Desktop devices enabling rapid deployment in the field. The LG-100 LoRa receiver is powered by a 24 VDC/1.0W external power supply and is ideal for use with commonly used OEM controllers, PLC or DCS systems. LG-100 LoRa receiver is designed to offer a wireless data communication solution for critical industrial applications with great flexibilities yet affordable cost.

2. Specifications

Product	LG-100
Part Number (P/N)	28903
Power Supply	24 VDC, 1.0W Max
Bluetooth® Connectivity	Bluetooth 5.0® 4.1, 32 ft. (10 Meters) Line of Sight for use with uPyxis®
Radio Range	Up to 1.8 km line of sight
Radio Input	Long Range Radio (LoRa)
Wired Output	1x 4-20mA / RS-485 MODBUS
Output Cable	Waterproof 7-Pin (10ft / 3m) Cable with Adapter & Flying Lead
Extension Cable	Waterproof Extension Cables Sold Separately
Installation	LG-MB-002 Wall Mounting Bracket
Dimension	Height: 4.67 inch (118.6 mm); Length: 4.72 inch (120 mm); Width:3.31 inch (84 mm)
Enclosure Material	Polycarbonate (PC), Polybutylene Terephthalate (PBT)
Ambient Temperature	5 - 122 °F (-15 - 50 °C)
Storage Temperature	-4 - 140 °F (-20 - 60 °C)
Pressure	-29 - 58 PSI (-0.2 - 0.4 MPa)
Enclosure Rating	IP66
Display	1.3 - inch OLED display
Regulation	UL / CE / RoHS / UKCA
Wireless Certified FCC ID	2BAJ2-LSR

**With Pyxis' continuous improvement policy, this specification is subject to change without notice.*

3. Unpacking Instrument

Remove the instrument and find the standard accessories from the shipping container as listed below. Inspect each item for any damage that may have occurred during shipping. Verify that all accessory items are included. If any item is missing or damaged, please contact Pyxis Lab Customer Service at service@pyxis-lab.com or by phone at 1-866-203-8397.

3.1 Standard Provided Accessories

The LG-100 LoRa receiver is delivered with the items outlined below.

LG-100 LoRa Receiver (P/N 28903)

One **MA-L10** Waterproof 7-Pin Cable with Adapter & Flying Leads (10ft /3m)

User Manual Can Be Downloaded [Support Documents - Pyxis Lab, Inc. \(pyxis-lab.com\)](https://www.pyxis-lab.com/support-documents)

3.2 Optional / Replacement Accessories

The following optional or replacement accessories are available for use with LG-100 LoRa receiver and are sold separately.

Ordering Information

LG-100 *(Includes MA-L10 10-foot Flying Lead Cable w/7Pin Waterproof Adapter)*

P/N

28903

Optional Accessories

LG-MB-W001 *(LG Series – Wall Mounting Bracket Kit Wall Mounting Installs)*

P/N

20523

MA-AC-7US *(110VAC-24VDC Power Supply Adapter – 7Pin Waterproof – USA Plug)*

26398

MA-AC-7EU *(230VAC-24VDC Power Supply Adapter – 7Pin Waterproof – EU/Din Plug)*

28787

MA-L10 *(Replacement Waterproof 10' Flying Lead Cable w/7Pin Waterproof Adapter)*

MA-L10

25' Waterproof Extension Cable *(7Pin Waterproof Adapters)*

MA-L25

50' Waterproof Extension Cable *(7Pin Waterproof Adapters)*

MA-L50

100' Waterproof Extension Cable *(7Pin Waterproof Adapters)*

MA-L100

LG-50 *(LoRa DTU – Converts Modbus 485/AI/DI to LoRa signal for All Pyxis Sensors)*

24817

LSR-801 *(24VDC Powered RADAR Level Sensor with LoRa)*

51959

LSR-803L *(24V or AA-Battery Powered RADAR Level Sensor with LoRa & Display)*

50191

4 Installation

4.1 Power and Wiring

The LG-100 LoRa receiver can be powered by a 24V DC power supply from any standard controller, PLC, DCS or a separate 24V DC power supply. The maximum power consumption of LG-100 is 1.0W. The device offers both 1x 4-20mA and 1x RS-485 Modbus outputs. The 24V DC negative (black wire) and 4-20mA- (green wire) are internally connected from the LG-100 therefore it is unnecessary to connect the green to the 4-20 mA negative terminal in the controller. If a separate DC power supply other than from a controller is used, make sure that the output from the power supply is rated for 22-26 VDC @ 100mA. Under standard installations the clear wire is not landed and remains unused.

NOTE Pyxis recommends powering off the controller when landing wires to the controller terminal board while the adapter to LG-100 is connected. Follow the wiring table below to connect the device to a controller or receiving device.

Wire Color	Designation
Red	24 V +
Black	24 V Power ground / 4-20mA-
White	4-20 mA +
Green	Not connected
Blue	RS-485 A
Yellow	RS-485 B
Clear	Shield, earth ground

4.2 Dimensions

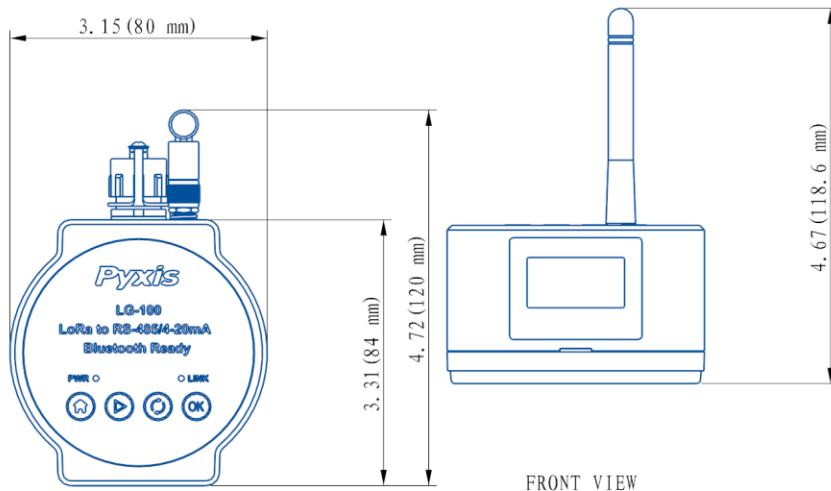

Figure 1. LG-100 Dimensions, inch (mm)

4.3 Installation Guide

The following guidelines should be followed when installing the LG-100.

- When installing in an open area, the antenna of the LG-100 and the antenna of the LoRa DTU (the device who converts Modbus/AI/DI into LoRa signal) should be kept at the same height as much as possible.
- When the LG-100 is installed in an area with a lot of obstacles, it should be mounted as high as possible so that the antenna is at a high position to minimize interference with communications.
- When there are more than one LoRa DTU devices and their antenna heights are not consistent, the LG-100 should be mounted as high as possible to ensure the LG-100 has less communication interference with all LoRa DTU devices.

4.4 Wall Mounting Bracket Installation

The LG-MB-W002 wall mount bracket is available as optional accessories (sold separately) for wall mounting installation of the LG-100 LoRa receiver. For the LSR Series Mounting Kit Installation Guide please contact service@pyxis-lab.com

WALL Mount Kit

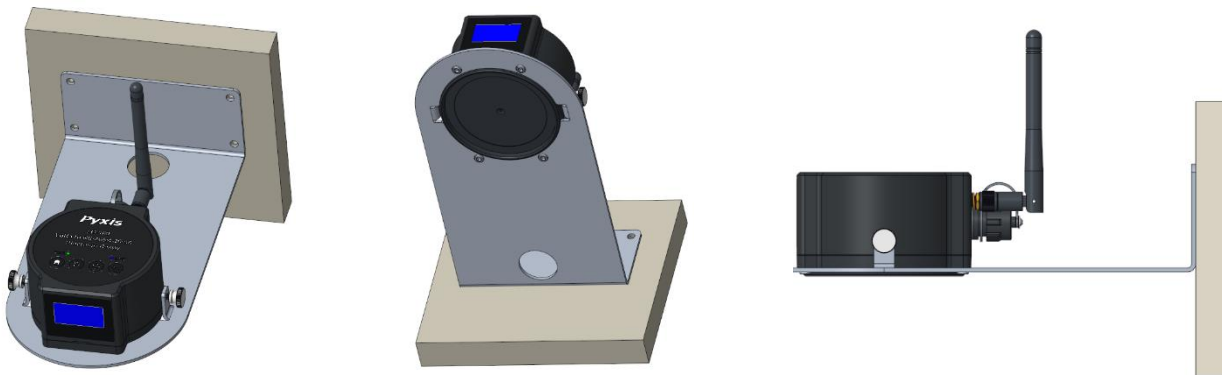

Figure 2. LG-MB-W001 (P/N 20523) Wall Mounting Bracket for LG-100

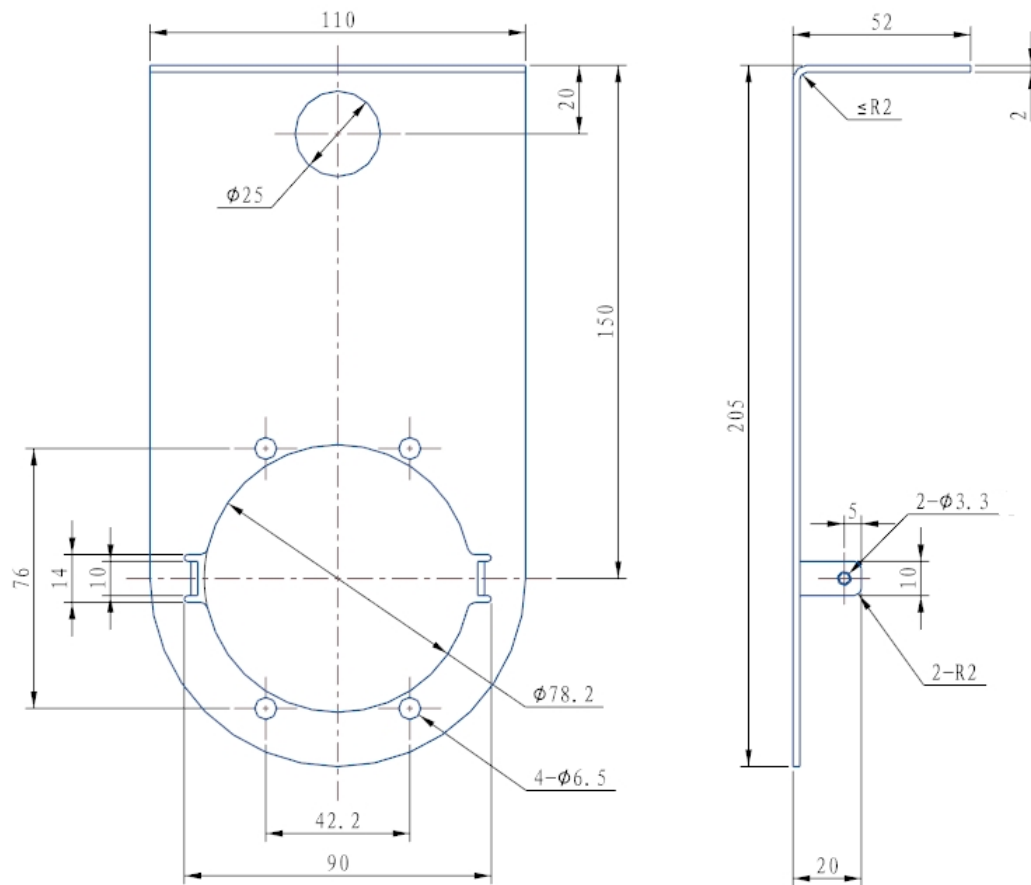

Figure 3. LG-MB-W001 Dimensions (mm)

5 Instrument Overview

5.1 LED Indicators

The LED indicators on the top of the device (Figure 4) are used to indicate device status and Bluetooth 5.0® connection status.

LED Status	ON	OFF
Green LED	Power Supply is ON and device is running	Power Supply is OFF
Blue LED	Bluetooth 5.0® is connected	Bluetooth 5.0® is disconnected



Figure 4. Power and Bluetooth LEDs

5.2 Function Buttons

Home Button

- Press and hold the Back button for 1 second to go back to upper-level menu.
- If already in the home screen, press and hold the button for 1 second to switch between home screen and settings screen.



Page Switch Button

- Press and hold this button for 1 second to go to next page if there are multiple pages in current screen.



LoRa DTU Switch Button



- Press and hold this button for 1 second in home screen to display detailed LoRa DTU information.







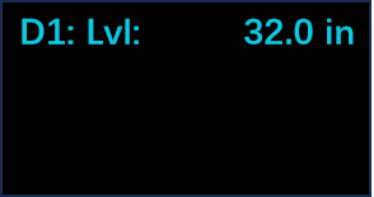
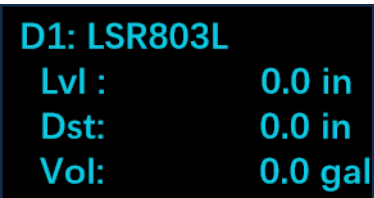
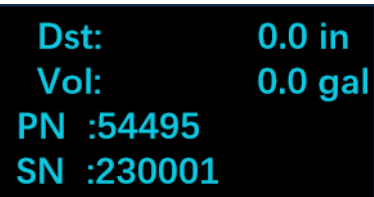

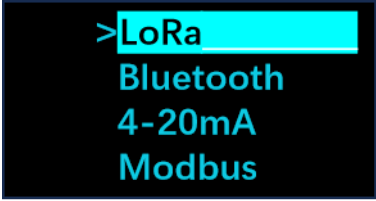

Confirm Button

- Press and hold this button for 1 second to apply settings change in settings menu.

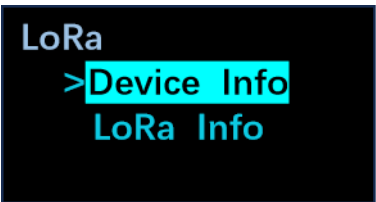
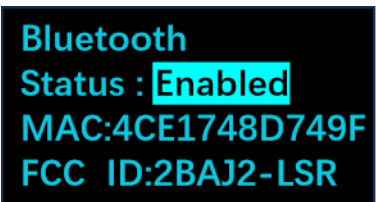
5.3 OLED Display Symbols & Definitions

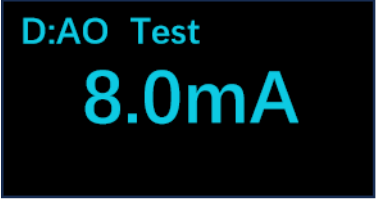
OLED SCREENS	DEFINITION
 	<p>LG-100 home screen displays the LoRa communication parameters when no LoRa DTU device connected.</p> <p>When there are LoRa DTU devices connected, the home screen will display the data uploaded from LoRa DTU devices.</p>
 	<p>Click the  Page Switch button on the home screen to display the LoRa DTU device screen. This page displays the uploaded sensor data from the LoRa DTU device as well as the product number and serial number of the sensor connected to LoRa DTU device.</p>

 	<p>Click the  Home button in the home screen to display the main menu, click  Page Switch button in main menu to select different menu item. The following sections will describe details of each menu item.</p>
	<p>There are two sub-items in LoRa page.</p> <ul style="list-style-type: none"> • Device Info displays the LoRa DTU device information. • LoRa Info displays the LG-100 LoRa settings.
	<p>The Bluetooth page displays the Bluetooth Status, Bluetooth MAC address and FCC ID number. Click  Confirm button in this page will toggle between Bluetooth enable and disable.</p>
	<p>The 4-20mA page displays the LG-100 4-20mA output signal as well as the source of 4-20mA output. The source can be a sensor value from the LoRa DTU device or LG-100's 4-20mA test output.</p>

<div data-bbox="203 247 578 449" style="background-color: black; color: cyan; padding: 10px; text-align: center;"> NO Device </div> <div data-bbox="203 485 578 686" style="background-color: black; color: cyan; padding: 10px;"> MB Output 1-1 Distance: 51001 4-20mA: 51003 Level: 51005 </div>	<p>The Modbus page displays Modbus register addresses assigned for each LoRa DTU device. If there is no device connected via LoRa, the page will display No Device.</p>
<div data-bbox="203 751 578 953" style="background-color: black; color: cyan; padding: 10px;"> System > LoRa 4-20mA Modbus </div> <div data-bbox="203 989 578 1190" style="background-color: black; color: cyan; padding: 10px;"> System Modbus Date&Time > Info </div>	<p>Click the  Page Switch button in System page to select different functions to configure the <u>LoRa parameters</u>, <u>4-20mA output settings</u>, <u>Modbus parameters</u> and <u>Local Date/Time settings</u>.</p>
<div data-bbox="203 1247 578 1449" style="background-color: black; color: cyan; padding: 10px;"> LoRa Settings MID:1 Freq:903.0MHz BW:500KHz </div> <div data-bbox="203 1484 578 1686" style="background-color: black; color: cyan; padding: 10px;"> LoRa Settings SF:9 Tx Power:20 Mode: Protocol </div>	<p>The LG-100 LoRa communication parameters can be configured in the LoRa Settings page. *NOTE* Make sure you setup the same <u>Freq</u>, <u>BW</u> and <u>SF</u> for both the LG-100 and LoRa DTU devices.</p>

<p>4-20mA Settings AO DEV: Device1 AO:0.0mA</p>	<p>Select the 4-20mA source in the 4-20mA Settings page. The 4-20mA source can be a LoRa DTU device or LG-100 local test output.</p>
<p>MB Settings MB ID: 93 Baudrate:9600 Parity:EVEN</p>	<p>Set the Modbus RS-485 parameters in the MB Settings page. *NOTE* Please power cycle the LG-100 device to make the new Modbus parameters take effect.</p>
<p>Del Device Delete One Delete All</p>	<p>LoRa DTU device can be removed from LG-100 in Del Device page. In this page, choose Delete One to remove one LoRa DTU device from LG-100 (further specify which device to be removed) and Delete All will remove all connected LoRa DTU devices.</p>
<p>Date&Time 2022 - 12 - 12 12:12:12</p>	<p>Set LG-100 local date and time in the Date & Time page.</p>
<p>System Info PN:28903 SN:220001 HW Ver:V1.1</p> <p>System Info HW Ver:V1.1 SW Ver:1.0r00 EC : 0</p>	<p>Obtain the LG-100 device information in System Info page.</p>

6 Setup with uPyxis 2.0 Mobile App

6.1 Download the uPyxis 2.0 Mobile App

Download uPyxis 2.0 Mobile APP from [App Store](#) or [Google Play](#).



6.2 Connecting to uPyxis 2.0 Mobile App

Turn on the Bluetooth 5.0® on in your mobile device.

NOTE Do not pair the phone's Bluetooth to LG-100 device, the uPyxis 2.0 App will do the pairing.

Open uPyxis 2.0 Mobile App. Click "Scan Bluetooth" button and the App will start to search for Pyxis devices. Click the Connect button under **LG-100** to connect to it.

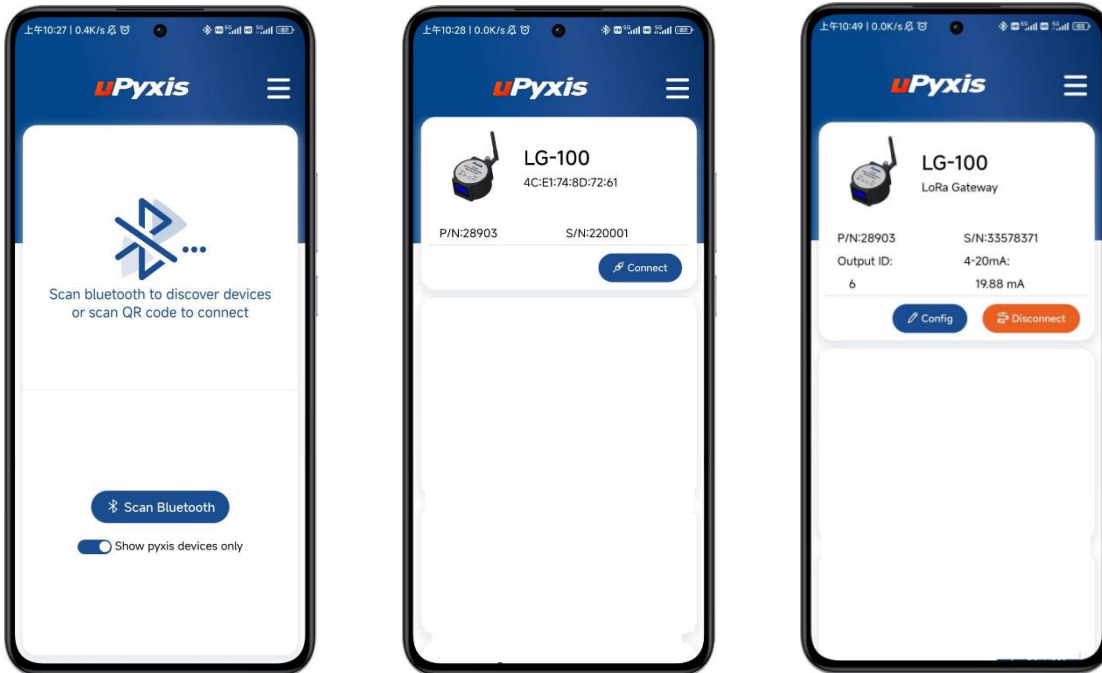

Figure 5. LG-100 Connection

6.3 Parameter Setting via uPyxis Mobile App

Once connected to LG-100, the uPyxis 2.0 App will display the device configuration page. The user can click on different menus to read the LG-100 device information or make changes to its settings as shown in Figure 6.

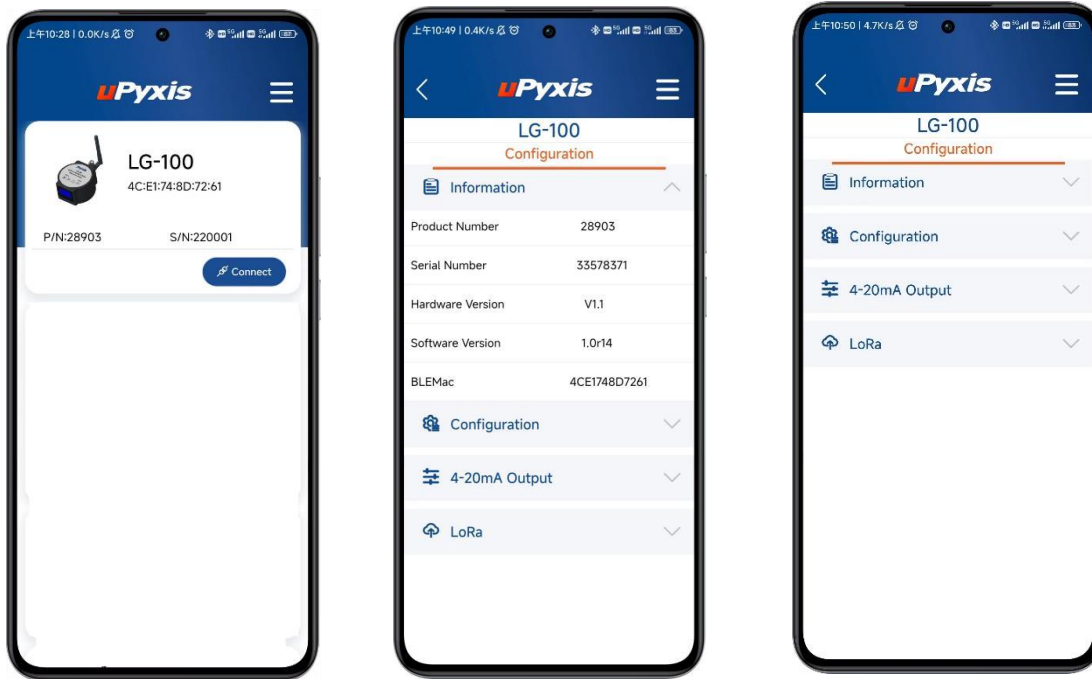

Figure 6. LG-100 Configurations

- Click the "**Information**" menu to display basic information of the LG-100 device, i.e., product number, serial number, hardware version number, software version number and Bluetooth MAC address.
- Click the "**Configuration**" menu to rename the device name and change its Modbus communication settings.
- Click the "**4-20mA Output**" menu to display current 4-20mA output value, 4-20mA output source can also be set in this menu.
- Click the "**LoRa**" menu and three additional submenus under LoRa will be displayed: **Information**, **Configuration** and **Diagnostics**, allows displaying/configuring and diagnosis of the LoRa communications as shown in Figure 7 on the next page.

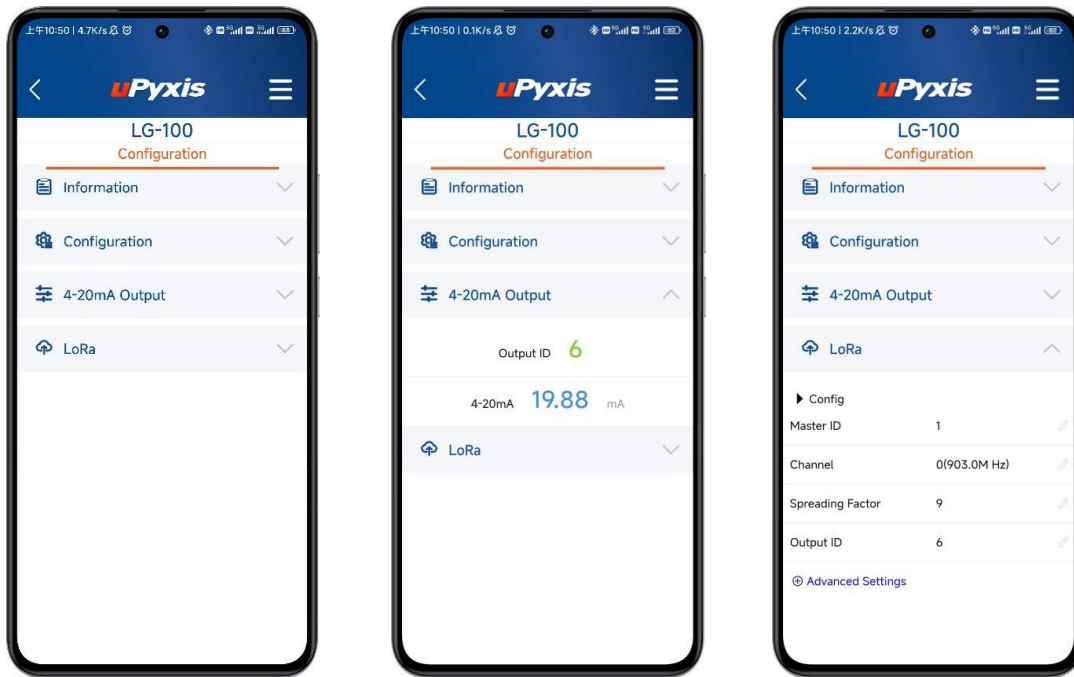

Figure 7. LG-100 Configuration Menu

7. Regulatory Approval

United States

The LG-100 has been tested and found to comply with the limits for a Class B digital device, pursuant to part 15 of the FCC Rules. These limits are designed to provide reasonable protection against harmful interference in a residential installation. This equipment generates, uses and can radiate radio frequency energy, and if not installed and used in accordance with the instructions, may cause harmful interference to radio communications. However, there is no guarantee that interference will not occur in an installation. If this equipment does cause harmful interference to radio or television reception, which can be determined by turning the equipment off and on, the user is encouraged to try to correct the interference by one or more of the following measures:

- Reorient or relocate the receiving antenna.
- Increase the separation between the equipment and receiver.
- Connect the equipment into an outlet on a circuit different from that to which the receiver is connected.
- Consult the dealer or an experienced radio/TV technician for help

Canada

This device complies with Industry Canada license exempt RSS standard(s). Operation is subject to the following two conditions: (1) this device may not cause interference, and (2) this device must accept any interference, including interference that may cause undesired operation of the device.

Le présent appareil est conforme aux CNR d'Industrie Canada applicables aux appareils radio exempts de licence. L'exploitation est autorisée aux deux conditions suivantes: (1) l'appareil ne doit pas produire de brouillage, et (2) l'utilisateur de l'appareil doit accepter tout brouillage radioélectrique subi, même si le brouillage est susceptible

Contact Us

Pyxis Lab, Inc.

21242 Spell Circle Dr.

Tomball, TX 77375 USA

www.pyxis-lab.com / service@pyxis-lab.com