

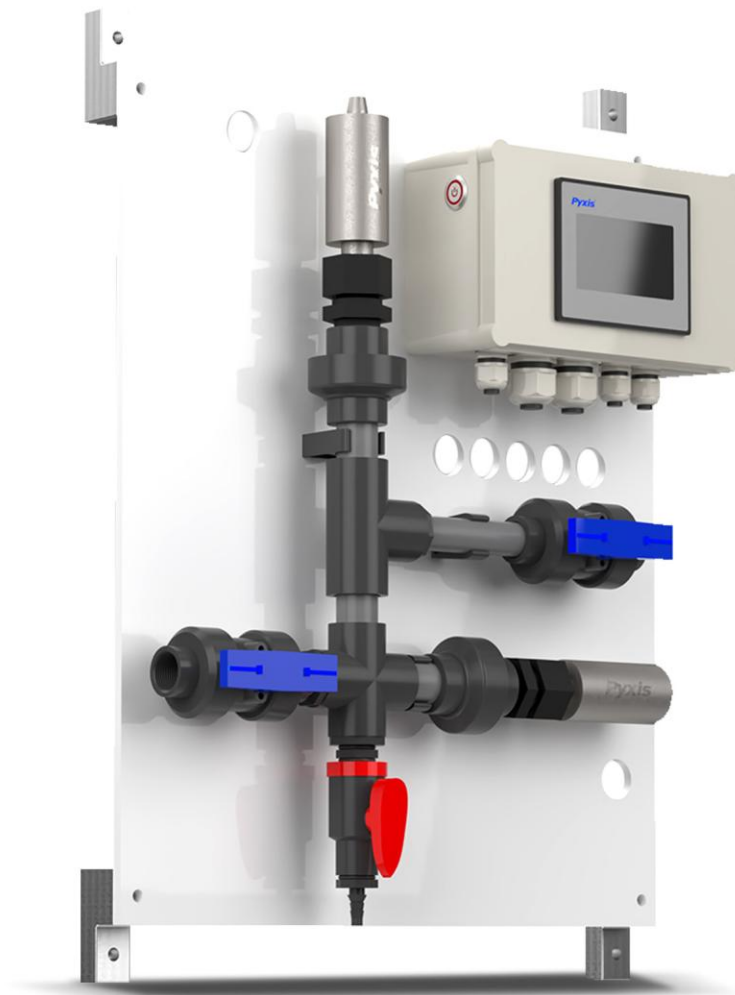

IK-300 Series Corrosion Rate Analyzer

Using CR-300 LPR Corrosion Rate Sensors



Pyxis Lab® Inc.
21242 Spell Circle
Tomball, TX 77375
www.pyxis-lab.com

**USER
MANUAL**

General Information

In no event will the manufacturer be liable for direct, indirect, special, incidental or consequential damages resulting from any defect or omission in this manual. The manufacturer reserves the right to make changes in this manual and the products it describes at any time, without notice or obligation. Revised editions are found on the manufacturer's website.

Safety Information

Please read this entire manual before unpacking, setting up or operating this equipment. Pay attention to all danger, warning and caution statements. Failure to do so could result in serious injury to the operator or damage to the equipment.

To make sure that the protection provided by this equipment is not impaired, do not use or install this equipment in any manner other than that specified in this manual.

Use of Hazard Information



DANGER

Indicates a potentially or imminently hazardous situation which, if not avoided, will result in death or serious injury.



WARNING

Indicates a potentially or imminently hazardous situation which, if not avoided, could result in death or serious injury.



CAUTION

Indicates a potentially hazardous situation that may result in minor or moderate injury.

NOTICE

Indicates a situation which, if not avoided, may cause damage to the instrument. Information that requires special emphasis.

Precautionary Labels

Read all labels and tags attached to the instrument. Physical injury or damage to the instrument could occur if not observed.





	This symbol, if noted on the instrument, refers to the instruction manual for operation and/or safety information.
	This symbol, when noted on a product enclosure or barrier, indicates that a risk of electrical shock and/or electrocution exists.
	Delicate internal electronic components can be damaged by static electricity, resulting in degraded performance or eventual failure.
	Electrical equipment marked with this symbol may not be disposed of in European public disposal systems after 12 August of 2005. In conformity with European local and national regulations (EU Directive 2002/98/EC), European electrical equipment users must now return old or end-of-life equipment to the Producer for disposal at no charge to the user.

Table of Contents

- 1. Specifications & Overview - 1 -
- 2. Structure Description & Dimension..... - 3 -
- 3. Installation and Connection - 4 -
 - 3.1. Installation requirements..... - 4 -
 - 3.2. Electrical Connection & Wiring - 5 -
- 4. Touch Screen Operation - 6 -
 - 4.1. Initial Screen - 6 -
 - 4.2. User Login - 6 -
 - 4.3. Real-time Monitoring - 7 -
 - 4.4. Menu Bar - 9 -
 - 4.5. Parameter Setting - 10 -
 - 4.6. Calibration..... - 14 -
 - 4.7. Alarm Browsing..... - 16 -
 - 4.8. Historical Data - 17 -
 - 4.9. Historical Data Curve - 19 -
 - 4.10. User Management..... - 21 -
- 5. Modbus Communication Table - 22 -
 - 5.1. Mailing Address..... - 22 -
- 6. Contact Us - 22 -

1. Specifications & Overview

Item	IK-300	IK-301
P/N	42081	45464
Sensor	CR-300	CR-300-BSP
Sensor P/N	51007	51025
Sensor Thread Standard	1-inch NPT	1-inch BPST
General Corrosion Range (4-20mA Output)	0.001–10.000 (MPY Default Based on Metallurgy Selected in uPyxis)	
Max General Corrosion Range (4-20mA Output)	0.001–995	
Localized Corrosion Range (4-20mA Output)	0.001–100	
Max Localized Corrosion Range (4-20mA Output)	0.001–100	
Conductivity Compensation	10 - 10,000 μ S/cm	
Resolution	0.001 MPY	
Alloy Factor	0 – 3 (Adjustable Default Assigned via uPyxis on Metallurgy UNS Code)	
Display	4.3-inch LCD Color Industrial Capacitive Touch Screen	
Storage Capacity	Built-In 128MB of RAM up to 1-Million Data/Event Records	
Power Requirement	96-260VAC / 50-60 Hz; 60 W	
Output	2 x 4-20 mA / RS-485 Modbus - RTU / Modbus TCP	
Input	RS-485 Modbus - RTU	
USB	1 x USB host, for data downloading and screen upgrade	
Internet	RJ-45 socket, Modbus-TCP	
Panel Operational Temperature	40 – 113°F (4-45 °C)	
Storage Temperature	Instrument: -4 – 131°F (-20 – 55°C) / Sensors 32 – 122°F (0 – 50°C)	
Sample Water Temperature	40 – 104°F (4-40°C)	
Sample Water Pressure	7.25 – 30 psi (0.05 – 0.2Mpa)	
Sample Water Flow Rate	500 – 2,000mL / Minute	
Sample Line Size	¾-inch NPT	¾-inch BPST
Rating	IP-65 Panel-Display / IP-67 Sensors	
Regulation	CE / RoHS	
Relative Humidity	20% - 90% (No Condensation)	
Altitude	<6,561 feet (<2,000 Meter)	
Dimensions (HxWxD)	600H x 500W x 153D mm	
Approximate Product Weight	~ 15 kg	
Pyxis 4G CloudLink™	Included & Activated On Request with Enrollment Contact Pyxis Lab for details	

NOTE - Pyxis technology is continuously updated, this technical parameter may change at any time without notice

Product Description

The use of the LPR corrosion rate represents a valuable tool that can be easily and affordably deployed to provide both general and localized corrosion measurements in an instantaneous format. There is a common industrial misnomer that the use of inline LPR corrosion sensors should be identical to that of corrosion coupons. The LPR corrosion level represents the real-time electrochemical measurement of corrosion. While it may be linear with respect to the corrosion rate obtained from the weight loss of a coupon exposed to water for a long period, the LPR corrosion rate may not necessarily be the same exact value of the latter. The instantaneous nature of the device general corrosion measurement represents a “real-time condition” on a Mils-Per-Year (MPY) scale (1 Mil = 1/1,000 inch) based on the specific metallurgy being assessed and will in many cases vary, in a short time scale, from a corrosion coupon. The LPR data should be used to best understand the linear relationship with coupons and for real-time application performance assessment and adjustment.

The Pyxis CR-Series corrosion rate sensors are ideal for cooling and process water treatment monitoring where robustness and affordability are a must. The sensors utilize the linear polarization resistance (LPR) method to produce a raw signal. The raw signal is conditioned, amplified, and digitized directly in the sensor itself. This avoids the interferences and attenuation of the raw signal caused by long-distance wiring needed for other corrosion probes to a separate signal conditioner or transmitter box. The Pyxis corrosion sensors measure sample water conductivity directly and compensate for the conductivity impact on the LPR measurement up to 10,000 $\mu\text{s/cm}$. These unique product characteristics make the Pyxis LPR superior in performance and accuracy. In addition to the LPR measurement to obtain the general corrosion rate, the CR-Series sensors also measure electrochemical noise. The measured noise data is used to calculate an index to quantify the localized corrosion rate also referred to as pitting. The CR-300 is a standalone sensor that can be powered by a 24 VDC power source from the Pyxis UC-100S PLC based display/data logging terminal. The output data signals for both general and localized corrosion are terminated via RS-485 modbus using the provided 8Pin cables with quick adapters.

The UC-80 Controller utilizes proprietary Pyxis Lab smart sensor technology and a Pyxis touchscreen display and data logging terminal to accommodate a wide variety of sensors. The UC-80 Controller offers a convenient and easy-to-integrate installation form for quick installation and simple maintenance.

The UC-80 controller integrates a touch screen display/data logger interface for sensor calibration. The display/data logger provides 2 x 4-20mA Outlets, RS-485 and Modbus TCP. The sensors are all connected to the display/data logger via RS-485 modbus (RTU), allowing in the monitor touch screen Integrated sensor calibration interface and diagnostics.

The UC-80 also comes equipped with a deactivated Pyxis CloudLink 4G Gateway with global SIM card enabling wireless data transmission to any cloud data management program. For activation of this gateway, contact order@pyxis-lab.com for enrollment details.

2. Structure Description & Dimension

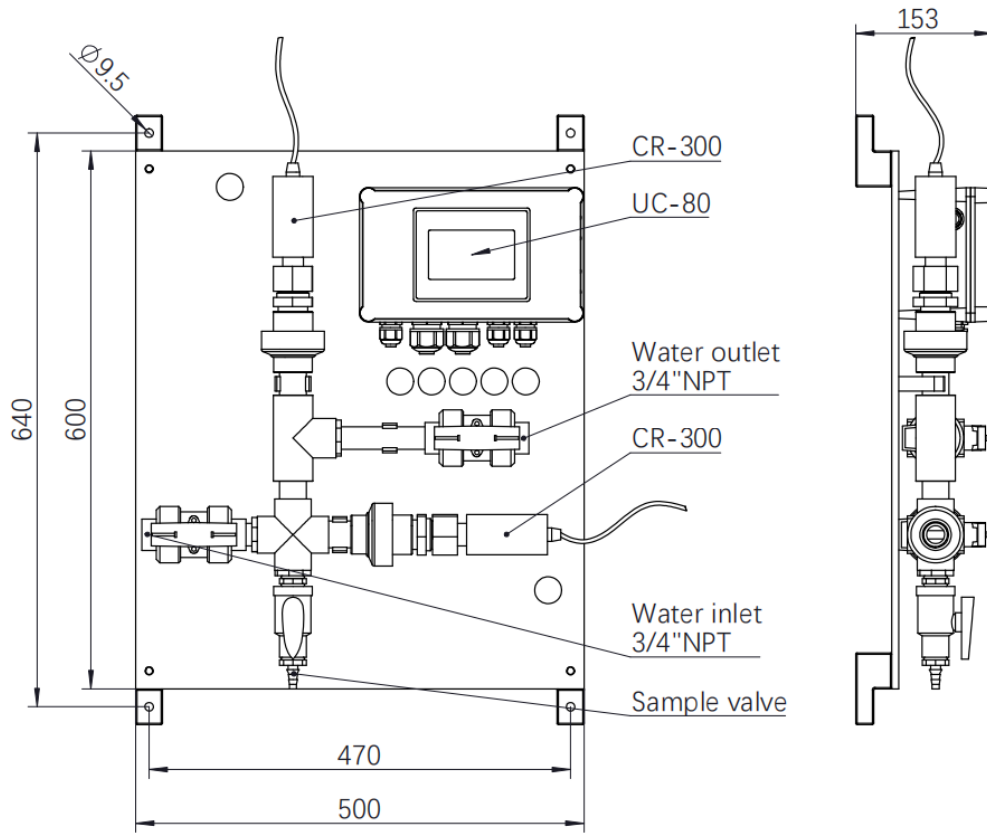

Figure. 1 IK-301 Analyzer

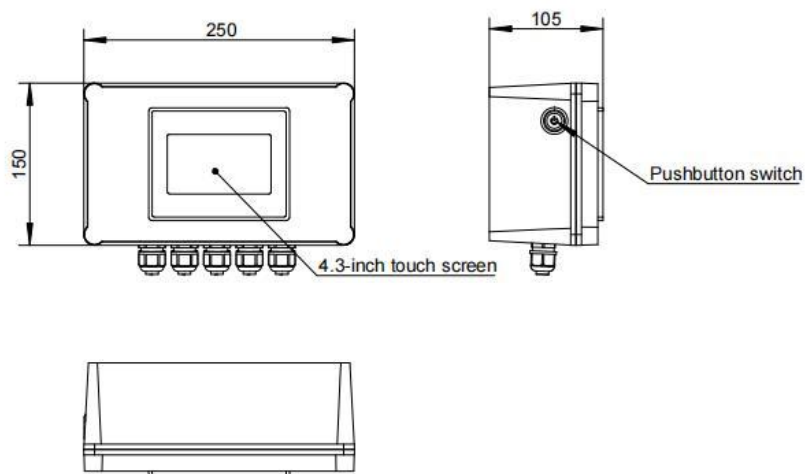

Figure. 2 UC-80 Display

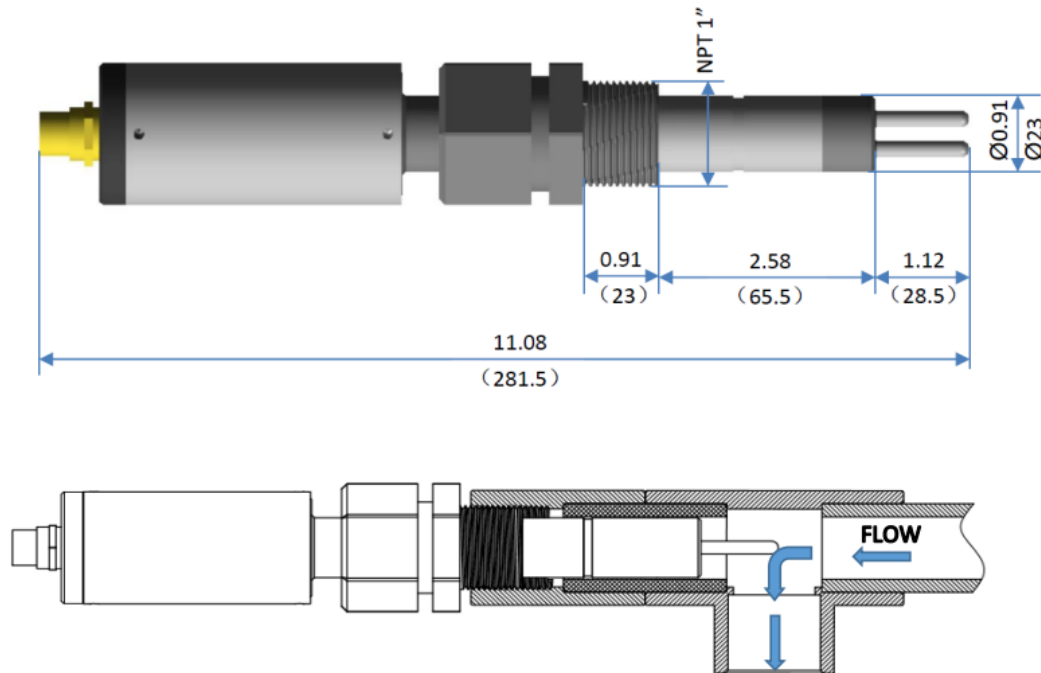

Figure. 3 CR-300 Dimension / CR-300 Installation Format

3. Installation and Connection

3.1. Installation requirements

Power Supply: 96-260VAC / 50-60 Hz; 60 W

Inlet Water Supply: Inlet pipe diameter is 3/4-inch FNPT. The inlet water pressure should be from 0.05-0.8MPa

Outlet Water Line: Outlet pipe diameter is 3/4-inch FNPT

Wall Mount Space: The IK-301 panel size is roughly 600H x 500W x 153D (mm) in dimension. Please leave at least 0.5m of installation space around the equipment for later maintenance.

Wall Mount Weight: Approximately 15kg. Please use appropriate mounting hardware.

3.2. Electrical Connection & Wiring

Users of online detection analyzer equipment only need to plug the power plug into a power socket of 100~240V AC 50/60Hz, and they can operate normally. The enlarged drawing can be seen in the attachment.

IMPORTANT NOTE Before the equipment is delivered, all the sensors will be preprogrammed for communication with the UC-80 via RS-485 and unique registers. However, if the sensors are replaced at the site, the replacement sensors will need to be matched one by one to assign new modbus registers. First connect the sensor, click **"Matching"** on the screen, wait for the match to succeed, restart the controller. Then connect another sensor, click **"Matching"**, wait for the match to succeed, restart the controller again.

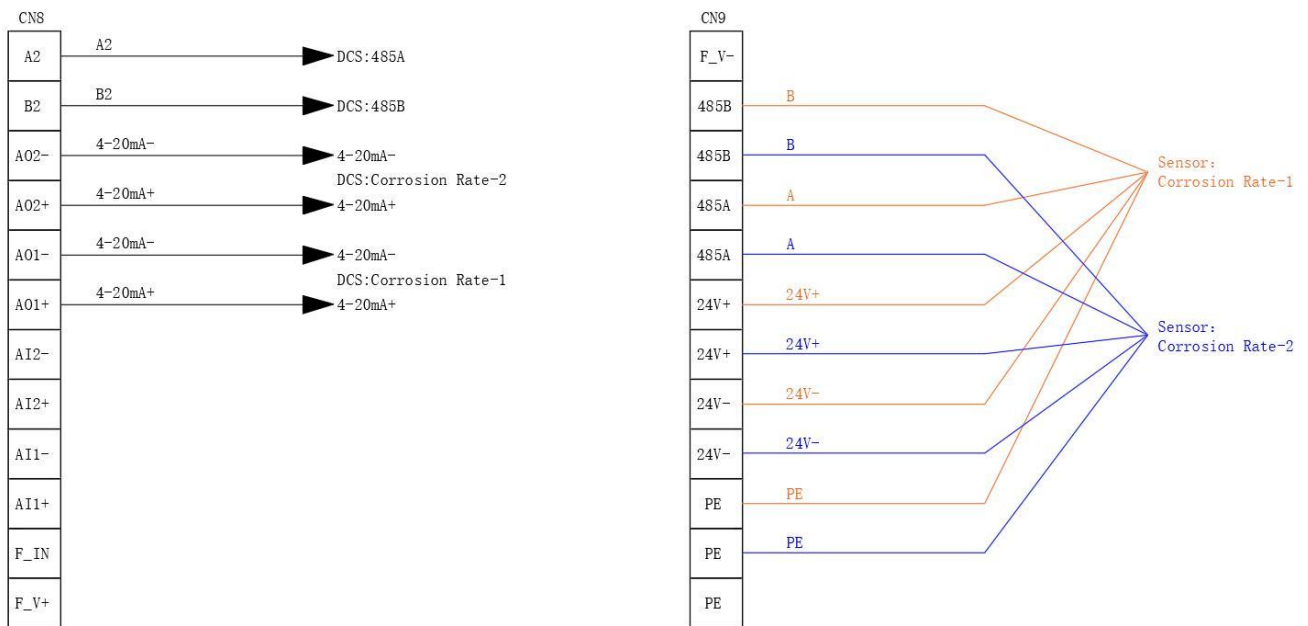

Figure. 4 UC-80 Terminal Connection Diagram

Warning: In the process of electrical connection, if you want to contact the 220V single-phase power supply, it should be operated by a person with an electrician certificate. Failure to follow the electrical operation specifications may cause electric shock injury or even death.

4. Touch Screen Operation

4.1. Initial Screen

After the system is powered on, the screen will open the initial screen, where the user can select the user to log in or enter the system.

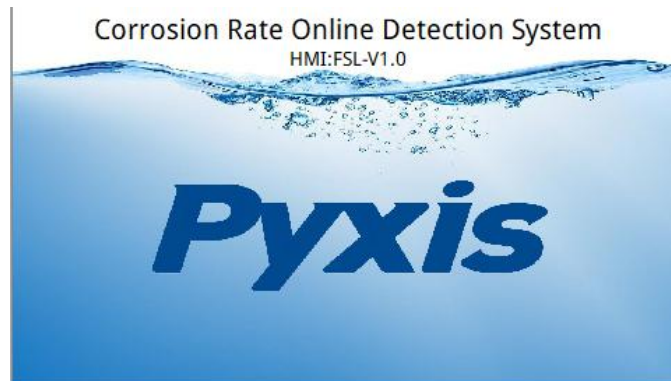

Figure. 5 Main Interface

4.2. User Login

After booting, the user needs to log in with the user name and password, otherwise they can only view the reading on the main interface, and cannot perform instrument parameter setting and calibration. Click the "User Login" button, a prompt box pops up: select the user "pyxis", enter the password: "888888" in the user password field.

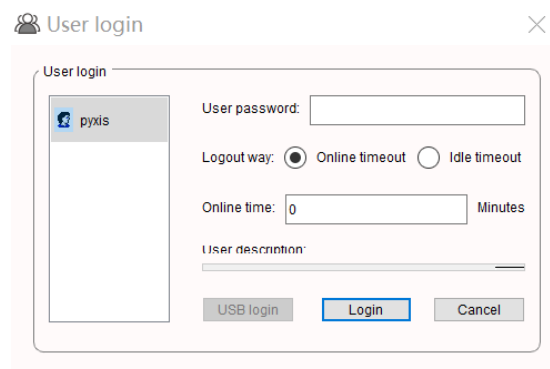

Figure. 6 User Login Interface

If you don't need a password or want to change the user, you can enter the system and perform "Management" in the "User Management" interface of the menu.

4.3. Real-time Monitoring

Click the "Enter System" button on the main interface to enter the real-time monitoring screen of the system, where the data detected by the sensor within 15 minutes will be displayed in real time.

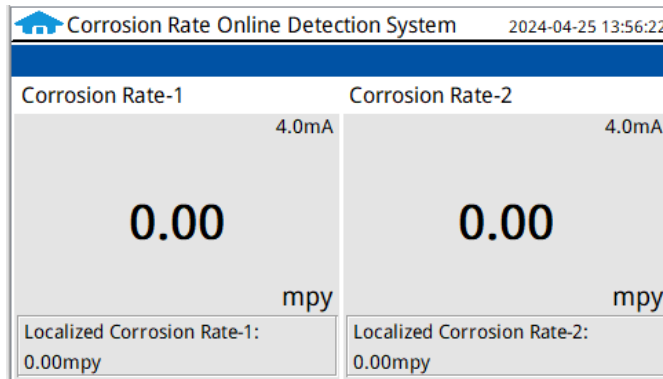

Figure. 7 Real-Time Monitoring Screen

IMPORTANT NOTE Before the equipment is delivered, all the sensors will be preprogrammed for communication with the UC-80 via RS-485 and unique registers. However, if the sensors are replaced at the site, the replacement sensors will need to be matched one by one to assign new modbus registers. First connect the sensor, click "Matching" on the screen, wait for the match to succeed, restart the controller. Then connect another sensor, click "Matching", wait for the match to succeed, restart the controller again.

When "*****" appears on the interface, it means that the sensor is abnormal or the communication fails.

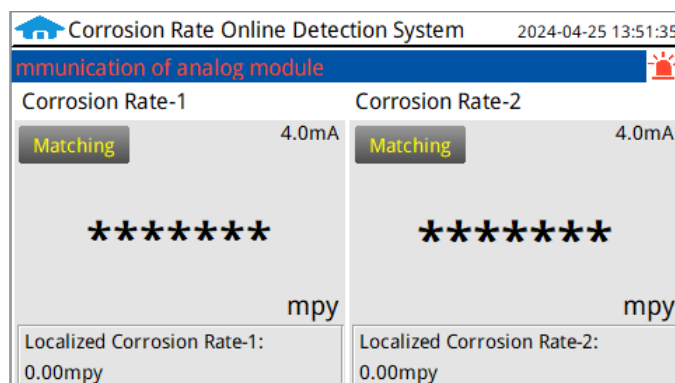

Figure. 8 Loss of Sensor Signal

After replacing the new sensor and confirming the connection, click "Matching" in the upper left corner of the corresponding interface, and you will be prompted to confirm the connection again.

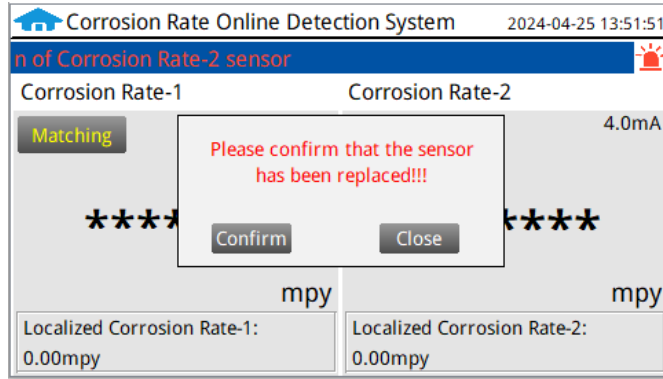

Figure. 9 Confirm Sensor Replacement

After clicking "Confirm", the system will start to match the sensors and wait for the matching to complete.

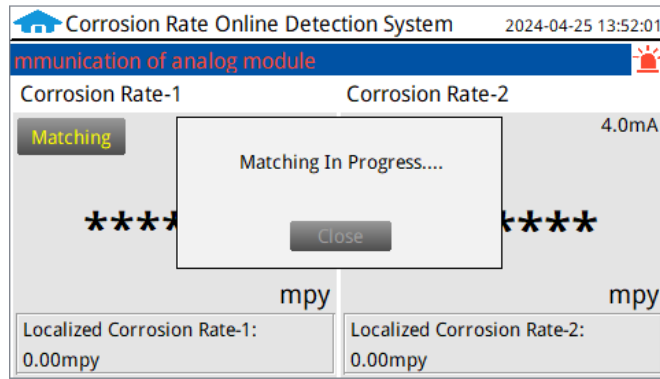

Figure. 10 Matching in Progress

When the prompt "Match Complete" indicates that the sensor is successfully matched, close the prompt box and it can be used normally.

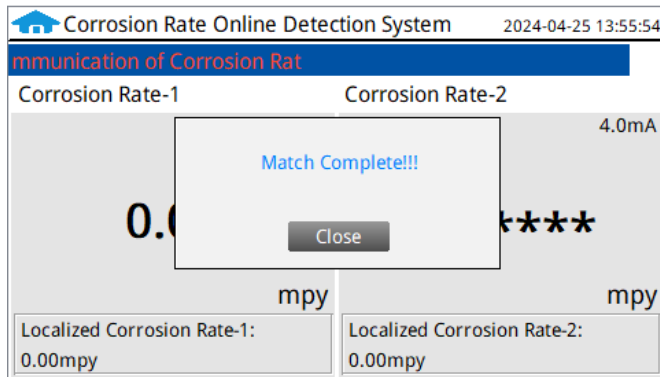

Figure. 11 Match Complete

When it prompts "Match Timeout", it means that the matching fails. Please confirm that the cable is connected correctly and repeat the above operations. If it still fails, please contact pyxis.

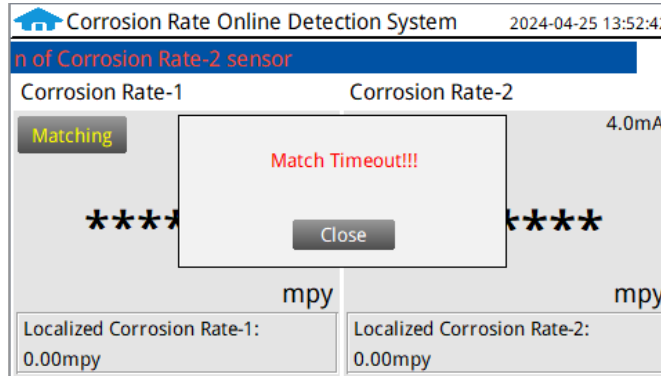

Figure. 12 Match Timeout

NOTE The above information applies only to replacement or damaged sensors. If the sensor is removed on site and the same sensor is reconnected, the controller will automatically connect without this operation.

4.4. Menu Bar

Click the "🏠" button in the upper left corner of the screen to enter the system menu interface, where the user can choose to enter the desired operation interface.

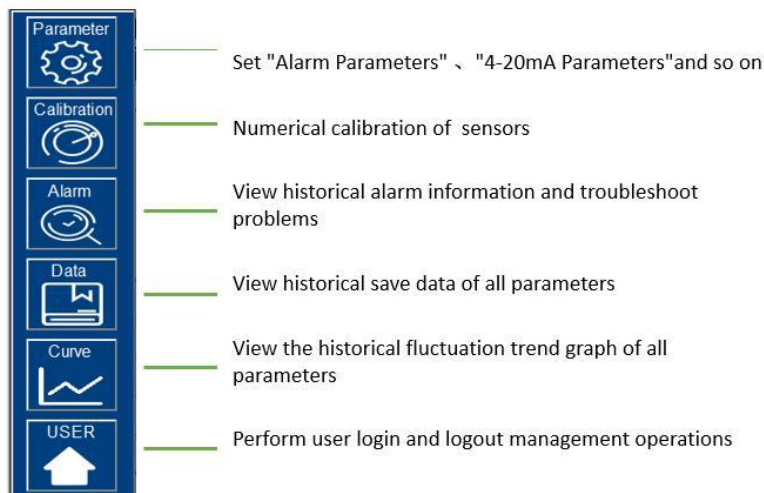

Figure. 13 Menu Bar

4.5. Parameter Setting

Click the "Parameter" button in the menu bar, you can choose to enter the "Alarm Parameters" 、 "4-20mA Output" setting interface:

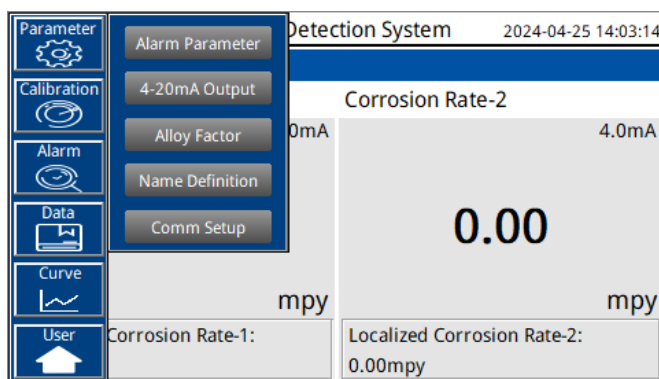

Figure. 14 Parameter Settings

Alarm Parameter

When the online user has the right to operate the instrument, the upper and lower limits of alarm can be set. Click "Alarm Parameters" to enter the interface of setting alarm parameters. When the measured value is lower than the set lower limit, the "**** lower limit alarm" of the corresponding sensor will be displayed in the real-time monitoring screen; when the measured value is higher than the set upper limit, the "**** upper limit alarm" of the corresponding sensor will be displayed in the real-time monitoring screen. Users can also choose to turn on or off the alarm display function at the top of the corresponding parameter

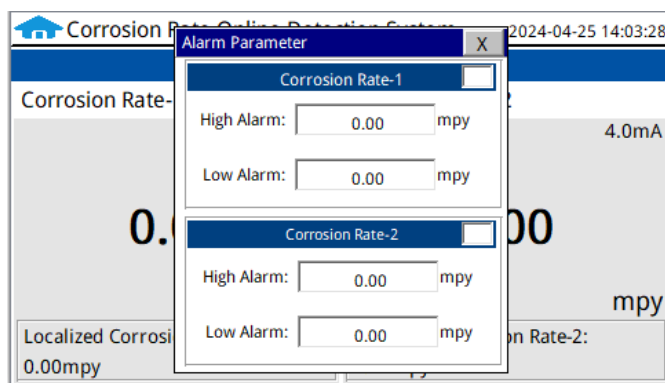

Figure. 15 Alarm Parameter Settings

Users can select the upper and lower limit alarm switch in the upper corner of each box.

Adjusting 4-20mA Output Parameters

Click "4-20mA parameter" to enter the 4-20mA parameter setting interface. The 4mA output value corresponds to the lower limit of the sensor range value, and the 20mA output value corresponds to the upper limit of the range value. The closer the value setting is to the measured value, the more accurate it is recommended to set according to the sensor range.

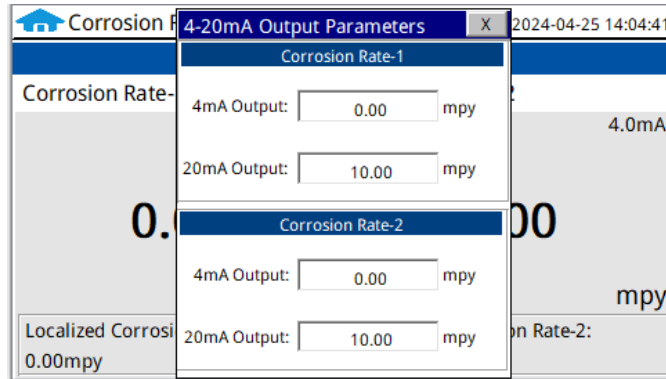

Figure. 16 4-20mA setting

Overview and Adjustment of the Alloy Factor

The default 4-20 mA current outputs for mild steel are scaled as:

- 4 mA = 0 MPY or 0 localized corrosion index
- 20 mA = 10 MPY (general corrosion)
- 20 mA = 100 MPY (localized corrosion)

The sensor is configured to measure the corrosion of mild steel by default. For measuring the corrosion rate of steel, the user just needs to scale 20 mA = 10 MPY in the controller.

Click "Alloy Factor" to enter the Alloy Factor selection interface. Select the model in the table in the lower left corner, click the "Load" button next to the corresponding sensor at the top, and the writing of the value means success. If there is no corresponding model in the table, you can manually enter it at the bottom right and add it to the table.

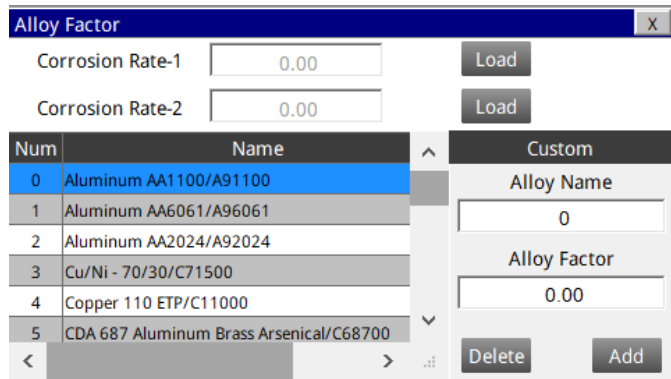

Figure. 17 Alloy Factor

Once an alternative metal has been selected via the Alloy Factor/Metallurgy drop down list, the user may refer to the metallurgy table below for appropriate analog output programming of alternative metals.

Common Designation	UNS	Alloy Factor	Default 4–20mA General Corrosion Scale (MPY)	Default 4–20mA Localized Corrosion Scale (Index)
Aluminum AA1100	A91100	0.94	0–10	0–100
Aluminum AA6061	A96061	0.94	0–10	0–100
Aluminum AA2024	A92024	0.86	0–10	0–100
Cu/Ni - 70/30	C71500	1.50	0–1	0–10
Copper 110 ETP	C11000	2.00	0–1	0–10
CDA 687 Aluminum Brass Arsenical	C68700	1.62	0–1	0–10
CDA 642 Aluminum Silicon Bronze	C64200	1.48	0–1	0–10
Arsenical Admiralty Brass CDA443	C44300	1.67	0–1	0–10
Phosphorized Admiralty Brass CD445	C44500	1.68	0–1	0–10
Pipe Grade Carbon Steel	A135	1.00	0–10	0–100
Mild Steel C1010	G10100	1.00	0–10	0–100
Mild Steel C1015	G10150	1.00	0–10	0–100
Mild Steel C1018-C1020	G10180	1.00	0–10	0–100
Mild Steel C1080	G10800	1.00	0–10	0–100
Stainless Steel 304	S30400	0.89	0–0.5	0–10
Stainless Steel 304L	S30403	0.89	0–0.5	0–10
Stainless Steel 316	S31600	0.90	0–0.5	0–10
Stainless Steel 316L	S31603	0.90	0–0.5	0–10
Duplex Stainless 2205 - F51	S31803	0.90	0–0.5	0–10
Duplex Stainless 2507 - F53	S32750	0.90	0–0.5	0–10
Common Lead	L50045	2.57	0–0.5	0–1

Figure. 18 Metallurgy Selection Reference List with Proper 4-20mA Output Scaling

*** IMPORTANT NOTE*** Pyxis Lab does not manufacture LPR electrodes. We provide some electrodes from Metal Samples Inc. as a convenience to our customer base. UNS Codes for each electrode format are provided in a table above. Users may purchase these electrodes directly from Metal Samples Inc. at <https://www.alspi.com/ms.htm>

Name Definition

Click the orange dialog box to customize the sensor name.

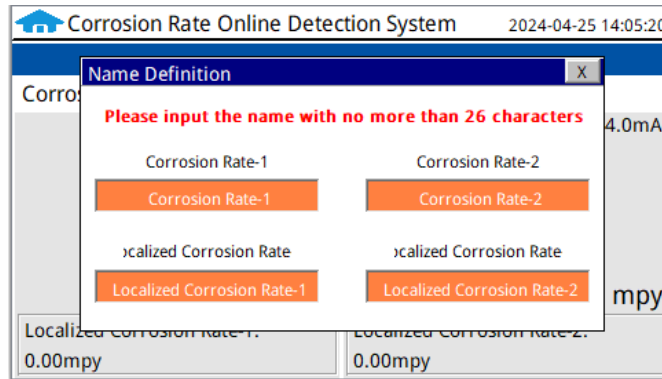

Figure. 19 - Name Definition

Communication (Modbus) Setup

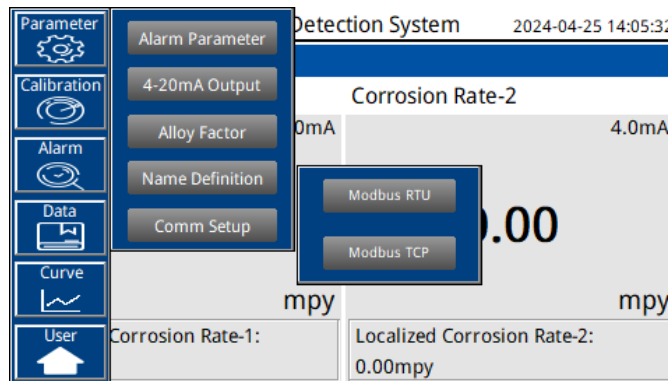

Figure. 20 Communication Setup

Communication parameters generally do not need to be changed. If the communication station number and other parameters need to be changed on site, they can be changed on this interface.

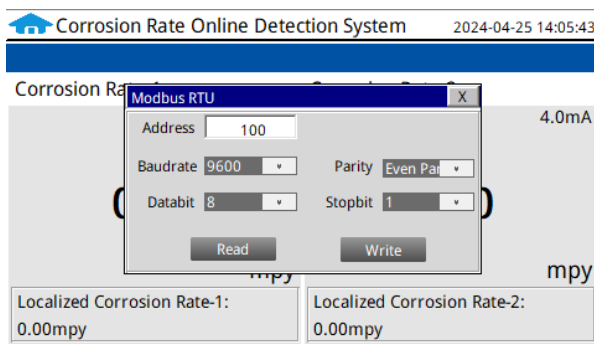

Figure. 21 DCS Communication Parameters

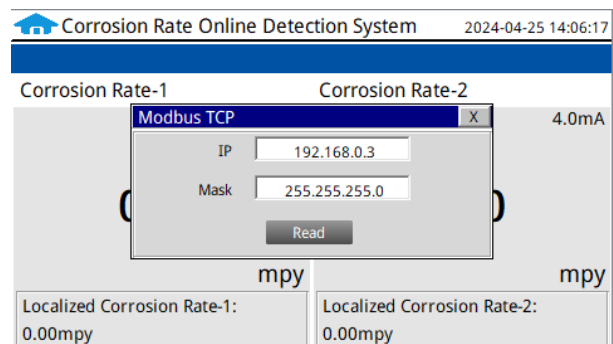

Figure. 22 Modbus TCP

4.6. Calibration

Click the "Calibration" button in the menu bar, and then select Calibration.

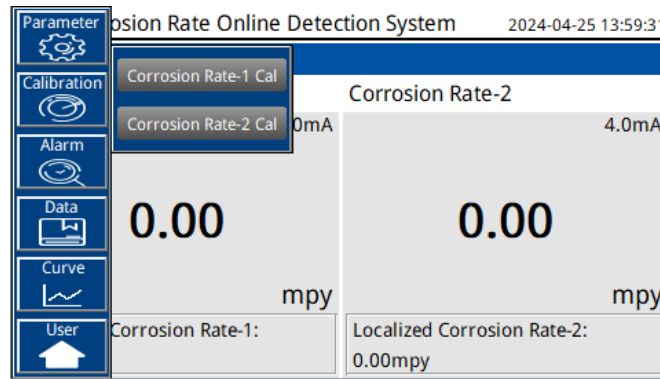

Figure. 23 Parameter Calibration

The general corrosion rate calibration screen prompts the user to place the probe into a **“Standard Solution”**. Please note that this term references the Pyxis Calibration-Check Caps that are provided with each CR-300 sensor. Two Calibration Check-Caps are provided with each CR-300 sensor, one for Steel and one for Copper. These caps produce a voltage equivalent to a generalized corrosion value in MPY (Mils Per Year), as outlined below.

Pyxis Calibration Check-Cap Specifications		
Calibration Check-Cap Metallurgy	Units of Measure	Corrosion Rate Output
Steel Calibration Check-Cap	MPY (mils/Year)	2.0
Copper Calibration Check-Cap	MPY (mils/Year)	0.1

With the proper metallurgy electrodes installed onto the CR-300, insert the sensors electrodes into the two holes of the Pyxis Calibration-Check Cap designed for the metal being measured. This is referenced as **“Standard Solution”** in the calibration interface of the Pyxis UC-80 display/data logging terminal.





Figure. 24 Installing the Calibration Check-Caps onto CR-300 with Electrodes

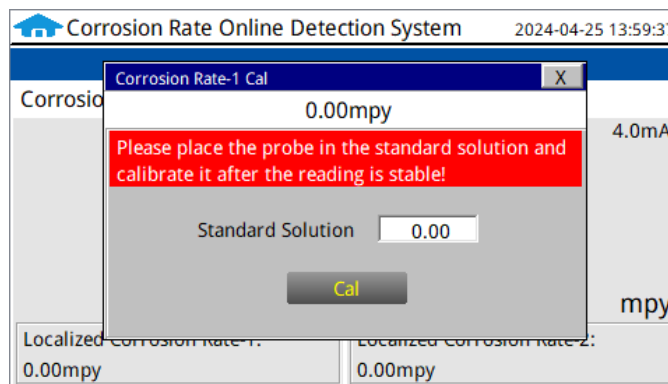

Figure. 25 Calibration Interface

Insert the sensor into the calibration check cap, or standard solution of known concentration. Enter the concentration in "**Standard solution**" and wait at least 15 minutes. After the value is stable, click the "**Cal**" button to start the calibration. When the following prompt box is displayed and the calibration is successful.

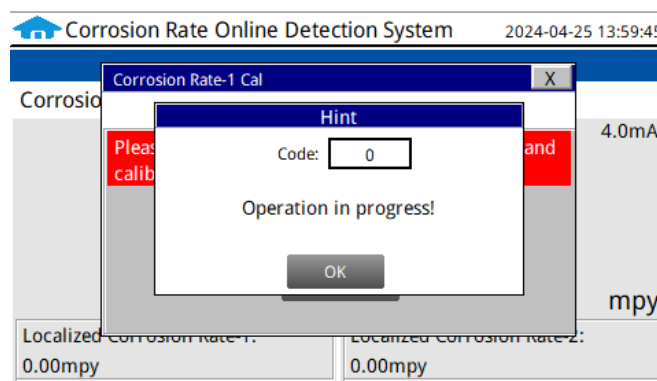

Figure. 26 Calibration Success

4.7. Alarm Browsing

Click the "Alarm Browsing" button on the main interface to enter the alarm browsing interface.

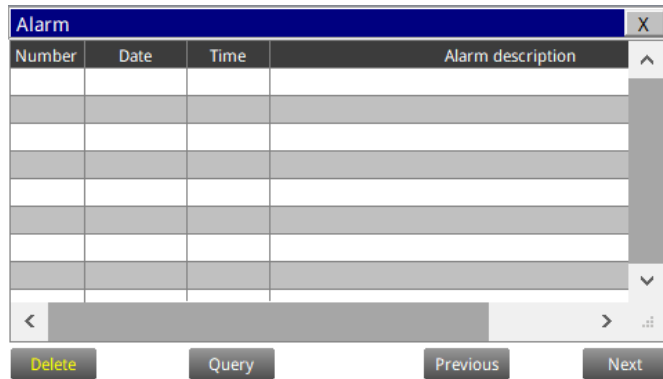

Figure. 27 Alarm Browsing

In this interface, the user can browse all alarm signals. Drag the right scroll bar to slide up and down to view historical alarm records. You can also click "Previous" and "Next" to turn pages quickly.

Click "Query", enter the number in the pop-up box and query, you can quickly view the alarm problem of the corresponding number.

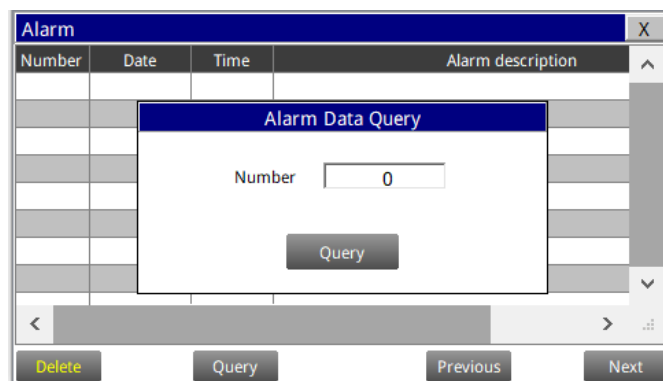

Figure. 28 Alarm Data Query Interface

After clicking the delete button in the lower left corner, all alarm records will be deleted. After clicking delete, you need to exit the current interface and enter again, the historical data in the data report will be cleared.

4.8. Historical Data

Click the "Historical Data" button in the menu bar to enter the data report interface.

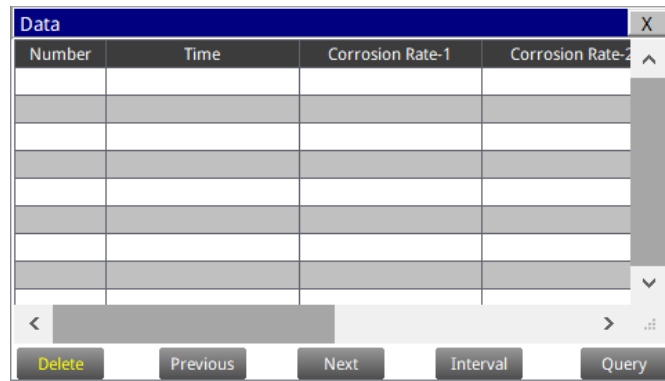

Figure. 29 Historical Data Interface

In the data report, the user can view the stored data of all parameters. The system records sensor readings every 4 seconds by default. Drag the scroll bar on the right to slide up or down, or click "Previous" and "Next" to view historical data records. The data record can save 100,000 pieces of data, and more than 100,000 will overwrite the previous data.

The user can click the periodicity button to change the period time of the system recording data.

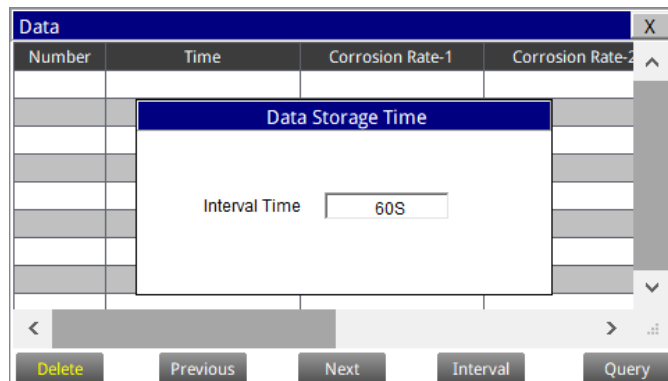

Figure. 30 Data storage cycle time Settings

Click Delete in the lower left corner. After entering the retention time, click the Delete button to clear all historical data except the retention time.

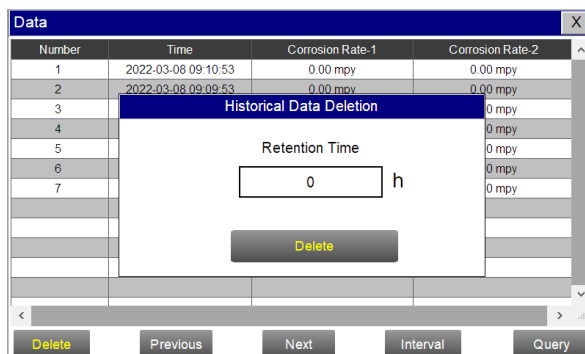

Figure. 31 Delete historical data interface

Click the query in the lower right corner, enter the start time and end time, and then click the query button, the data report will only display the historical data of the regional time. Note: The start time and end time need to be filled in completely according to the system time format (note the symbol format, which needs to be entered in the English input method state, you can refer to “Current Time”, otherwise it will not be recognized for query.

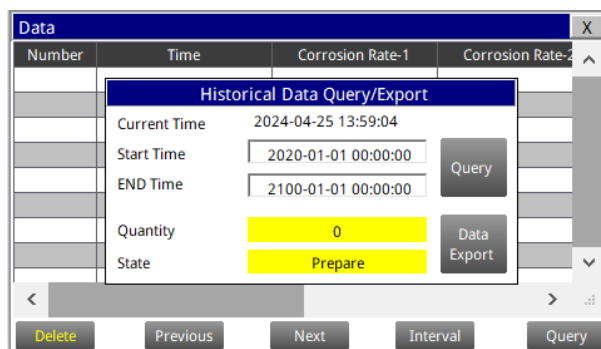

Figure. 32 Historical data query export interface

Insert the U disk behind the screen, and enter the time range of the data to be exported in the query area, click on the data export, when the status is displayed as success, and the quantity is positive, it means that the data export is successful; if the status is displayed successfully, the quantity is negative, indicating that the data was not successfully exported, please check whether the time format is correct.

If the Quantity column shows a negative value, you can refer to the list to see the problem:

Table. 1 Code Meaning

Code	Detailed question
-1001	Incorrect progress or control data object type
-1004	The group object name does not exist or the group object does not have the save attribute
-1020	The start time of the export is greater than the end time
-1021	U disk is not inserted
-1022	Only one export task is allowed at a time
-1023	The number of records read is 0
-1024	File operation failed
-1025	Export path is empty
-1026	Illegal export path
-1027	The time format is incorrect
-1028	Unsupported export mode

4.9. Historical Data Curve

Click the "historical curve" button in the menu bar to enter the trend curve interface. The ordinate is the monitoring value of the sensor, and the abscissa is the monitoring time. You can click the button below the abscissa to browse and view the values in different time periods. Clicking the Y-axis range will pop up the Y-axis range as shown in the figure. Enter the minimum and maximum values to change the displayed value of the Y-axis of the curve.

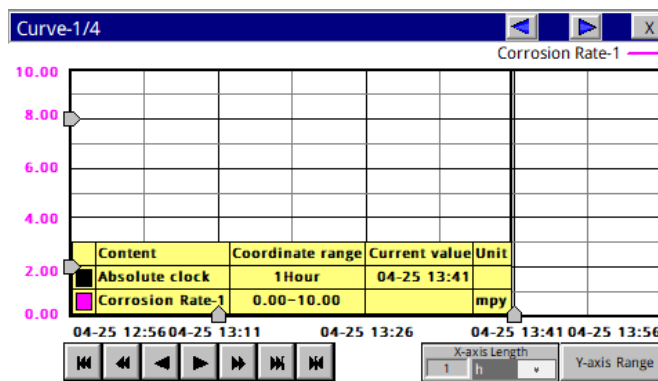

Figure. 33 Historical Curve Interface-1

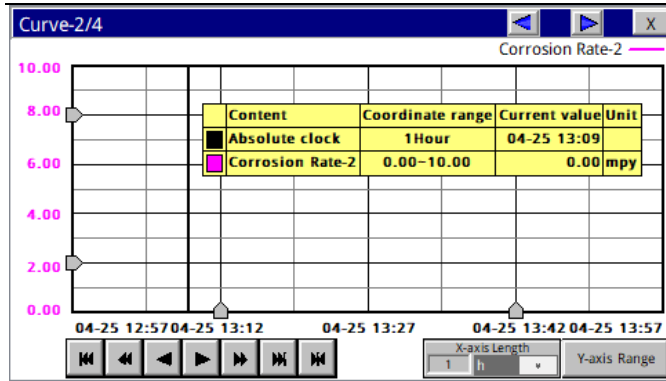

Figure. 34 Historical Curve Interface-2

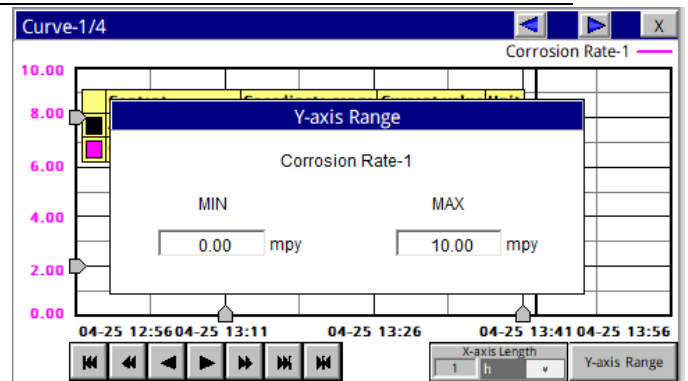

Figure. 35 Y axis range setting-1

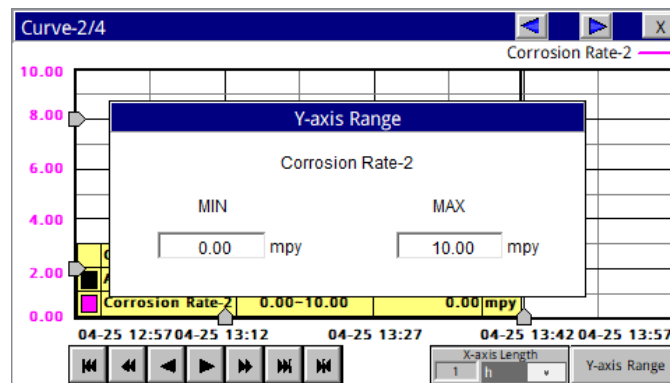

Figure. 36 Y axis range setting-2

- The curve will scroll back (to the left of the X-axis) one page
- The curve will scroll back (to the left of the X-axis) half the page of the curve
- The curve will scroll backward (to the left of the X-axis) to a position where the main line is drawn
- The curve will scroll forward (to the right of the X-axis) to a position where the main line is drawn
- The curve will scroll forward (to the right of the X-axis) half the page of the curve
- The curve will scroll forward (to the right of the X-axis) one page
- A dialog box will pop up to reset the starting time of the curve

Figure. 37 Button Introduction

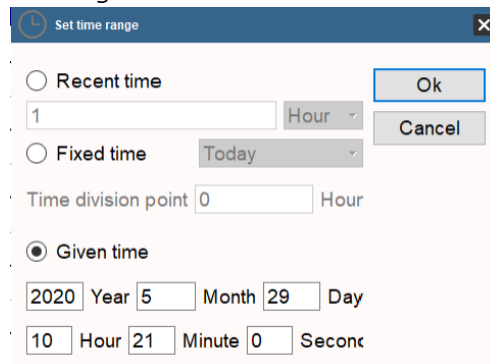

Figure. 38 Time Setting Interface

4.10. User Management

Click the "User Management" button on the menu bar, users can edit user information in this interface and switch between Chinese and English.

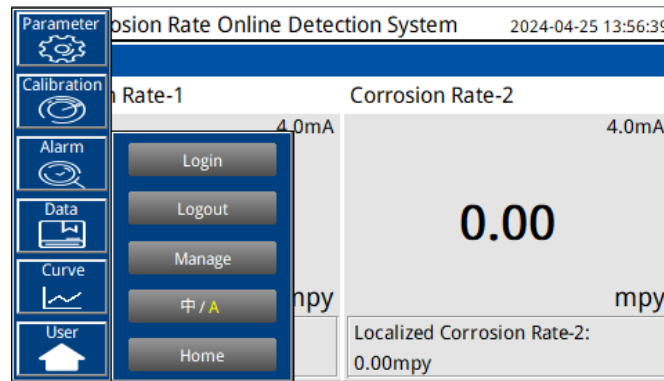

Figure. 39 User Management

Logout can make the user log out, and can only view the real-time reading, but cannot perform parameter setting and other operations.

Click **Manage** to enter the user management interface, where you can add users, modify passwords and other operations. Users can set their own user name and password, and select the user group to which they belong. Among them, only users in the administrator group can set parameters such as calibration.

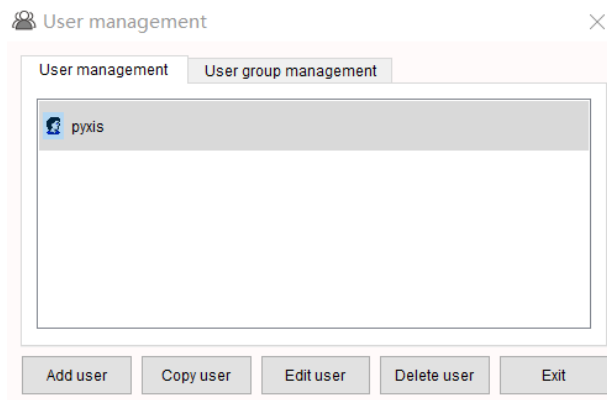

Figure. 40 User Management Interface

Change Password: Select the user to be changed, then click the Change User button, enter the user's own password in the User Password column and Confirm Password column, and click **Confirm** to modify successfully. ****NOTE*** If the user does not want to set a password, the password can be deleted and saved.*

5. Modbus Communication Table

5.1. Mailing Address

Table. 2 UC-80 Communication Address

No.	Define	Address	Format	Model	Unit	Note
1	Corrosion_Rate_1	1	float	Read only	mpy	Data format: ABCD
2	Corrosion_Rate_2	3	float	Read only	mpy	Data format: ABCD
3	Corrosion rate 1 lower alarm	5	uint	Read only		0: normal 1: alarm
4	Corrosion rate 1 upper alarm	6	uint	Read only		0: normal 1: alarm
5	Corrosion rate 2 lower alarm	7	uint	Read only		0: normal 1: alarm
6	Corrosion rate 2 upper alarm	8	uint	Read only		0: normal 1: alarm
7	Corrosion rate 1 The sensor communication is abnormal	9	uint	Read only		0: normal 1: alarm
8	Corrosion rate 2 The sensor communication is abnormal	10	uint	Read only		0: normal 1: alarm
9	Communication between analog modules is abnormal	11	uint	Read only		0: normal 1: alarm
10	Localized_Corrosion_Rate_1	12	float	Read only	mpy	Data format: ABCD
11	Localized_Corrosion_Rate_2	14	float	Read only	mpy	Data format: ABCD
Communication protocol: standard Modbus-RTU						
Communication parameters: baud rate -9600, data bit-8, stop bit-1, parity bit-even						
Station number: 100						
Communication protocol: Standard Modbus-TCP						
Communication parameters: IP: 192.168.0.3 (optional); Port: 502						
Station number: 1						

6. Contact Us

Contact Pyxis Lab

21242 Spell Circle

Tomball, TX. 77375

service@pyxis-lab.com for technical service and support

order@pyxis-lab.com for order and pricing inquiries

1-866-203-8397 Phone USA for all needs

Office Hours 7AM – 5PM Central Time USA