

Pyxis®

V1.6

DW-2300 Series

Inline Analyzers for Bottled/Beverage Water

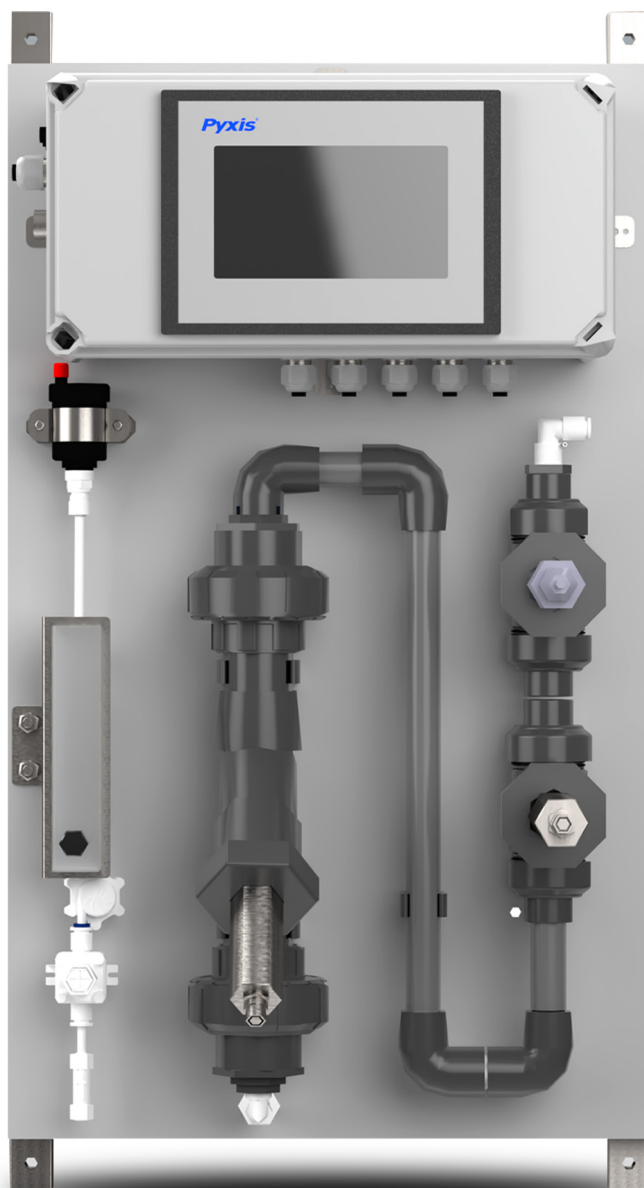

Pyxis Lab® Inc.

21242 Spell Circle
Tomball, TX 77375
www.pyxis-lab.com

USER MANUAL



Related Statements

The manufacturer shall not be liable for direct, indirect, special, incidental, or consequential damages resulting from any deficiency or omission in this manual. The manufacturer reserves the right to make changes to this manual and the products described in it at any time without notice or liability. Revised versions can be found on the manufacturer's website.

Safety Information

Please read this manual completely before unpacking, installing, and operating this equipment. In particular, pay attention to all dangers, warnings, and precautions, otherwise, it may cause serious personal injury to the operator or damage to the equipment.





Use of Danger Information

 Danger
Indicates a potentially or urgent dangerous situation that, if not avoided, will cause death or serious injury.
 Warning
Indicates a potentially or very dangerous situation that, if not avoided, may cause serious personal injury or death.
 Warning
Indicates a potentially dangerous situation that may cause a certain degree of personal injury.

Attention
Indicates conditions that if not avoided, will cause damage to the instrument. This is information that needs special emphasis.

Warning Label

Please read all labels and marks attached to the instrument. Failure to follow the instructions on these safety labels may result in personal injury or damage to the instrument.

	If this symbol appears in the instrument, it means refer to the operation and/or safety information in the instruction manual.
	If there is this mark on the instrument housing or insulator, it means there is a risk of electric shock or death from electric shock.
	Static electricity can damage the delicate internal electronic components, resulting in reduced performance or eventual failure of the instrument.
	Electrical equipment marked with this symbol cannot be disposed of through the European public waste system after August 12, 2005. In order to comply with European regional and national regulations (EU Directive 2002 / 98 / EC), European electrical equipment users must now return abandoned or expired equipment to the manufacturer for disposal without any cost.

Catalog

1. Specifications	- 1 -
2. Unpackaging	- 2 -
3. System Layout and Features	- 2 -
4. Dimension and Mounting	- 4 -
5. Installation	- 6 -
5.1. Installation Requirements	- 6 -
5.2. Tube connection	- 6 -
5.3. Terminal Wiring	- 8 -
6. Touch Screen Operation	- 9 -
6.1. Main Screen	- 9 -
6.2. User Login	- 9 -
6.3. Real-Time Monitoring	- 10 -
6.4. Menu Bar	- 11 -
6.5. Configurable Parameters	- 12 -
6.5.1. TDS/Cond Setup	- 12 -
6.5.2. Alarm Parameters Setting	- 13 -
6.5.3. Diagnostic Parameters	- 13 -
6.5.4. 4-20mA Output Parameters Setting	- 14 -
6.5.5. Communication Setting	- 14 -
6.6. Calibration	- 15 -
6.6.1. pH Calibration	- 16 -
6.6.2. Turbidity Calibration	- 18 -
6.6.3. Chlorine Calibration	- 22 -
6.6.4. TDS/Conductivity Calibration	- 23 -
6.7. Recovering Data	- 25 -
6.8. Alarm View	- 25 -
6.9. Historical Data	- 26 -
6.10. Historical Data Curves	- 28 -
6.11. User Management	- 30 -
7. Daily Maintenance	- 32 -
7.1. Correspondence Address	- 32 -
7.2. Operation and Maintenance	- 33 -
7.3. Instrument Alarms and Descriptions	- 34 -
7.4. Explanation and Use of the CHLORINE CHALLENGE Feature	- 35 -
7.5. Explanation and Use of the HOLD Feature	- 36 -
8. Replacing the ST-765SS Series Sensor Electrode Head Assembly	- 38 -
9. Updating Time, Date and Firmware	- 39 -
9.1. Setting the Time and Date	- 39 -
9.2. Firmware Update Procedure	- 41 -
10. Order Information	- 44 -

1. Specifications

Item	DW-2030P-US	DW-2030P-US-G
P/N	42164	42168
Turbidity Source / Wavelength	LED / Warm White	
Turbidity Dual Range	0.000 – 10.000 / 10.00 - 40.00 NTU	
Free/Total Chlorine Method	Bare Gold - Electrochemical Method	
Free/Total Chlorine Range	0.01 –5.00 ppm as Free or Total Cl ₂	
Selectivity	Non-Selective, Cross Sensitive to other oxidizing species	
pH Range	0.01 – 14.00 pH	
Conductivity Method	4-Graphite Electrode	
Conductivity Range	1 – 100,000 µS/cm	
Measurement Accuracy	0.001NTU or ± 1% Full Scale ±0.01 ppm or 1% Full Scale w/pH compensation to 9.0 ±0.01 pH ±1.5% µS/cm Conductivity	
Minimum Resolution	0.002 NTU 0.01 ppm 0.01 pH 1.0 µS/cm Conductivity	
Response Time	4s after immersion - Turbidity T95≤60s – Free Chlorine T95≤5s – pH T95≤5s – Conductivity	
Compliance	EPA-180.1/334.0	
Measurement Interval	Continuous Measurement	
Display	7-inch LCD Color Industrial Capacitive Touch Screen	
Storage Capacity	Built-In 4GB of Ram for Storing up to 1-Million Data/Event Records	
Power Requirement	96-260VAC / 50-60 Hz; 10A Fuse; 200 W	
Output	2 x 4-20 mA / RS-485 Modbus - RTU / Modbus TCP	
Input	2 x 4-20 mA / RS-485 Modbus - RTU	
USB	1 x USB host, for data downloading and screen upgrade	
Internet	RJ-45 socket, Modbus-TCP	
Panel Operational Temperature	40 – 113°F (4-45 °C)	
Storage Temperature	Instrument: -4 – 131°F (-20 – 55°C) / Sensors 32 – 122°F (0 – 50°C)	
Sample Water Temperature	40 – 104°F (4-40°C)	
Sample Water Pressure	7.25 – 30 psi (0.05 – 0.2Mpa)	
Sample Water Flow Rate	600-1,000mL / Minute	
Sample Line Size	¼-inch Inlet / ⅜-inch Outlet	
Rating	IP-65 Panel-Display / IP-67 Sensors	
Regulation	CE / RoHS	
Relative Humidity	20% - 90% (No Condensation)	
Altitude	<6,561 feet (<2,000 Meter)	
Dimensions (HxWxD)	Panel (DW-2030P) 790H x 450W x 280D mm	
Approximate Product Weight	DW-2030P ~ 15 kg	
Pyxis 4G CloudLink™	NA	Included
CloudLink™ Bands	NA	Global (B1/2/3/4/5/7/12/13/14/20/28/66/7)
CloudLink™ Protocols	NA	IP/TCP/UDP/HTTP/HTTPS/Modbus

NOTE -Specifications may change without notice. Pyxis Sensor Manuals can be found at www.pyxis-lab.com/shop

2. Unpackaging

The package includes the following items:

- One DW-2030P Beverage Water Panel Assembled and Complete with Power Supply Cord
 - One UC-100A Series Touch Screen Display/Data Logger with Pyxis Sensors Prewired in RS-485 (RTU)
 - One LT-739 Ultra-Low Turbidity Sensor
 - One ST-765SS-FCL – Chlorine / pH / Temperature Sensor
 - One ST-720 Conductivity/TDS Sensor
 - One FT-100 Inline Flow Tee Assembly for LT-739
 - Two ST-001 Inline Flow Tee Assemblies For ST-765SS and ST-720
 - One Pyxis CloudLink™ – 4G Gateway (as selected models ending in “G”)

3. System Layout and Features

The DW-2030P series is a multi-parameter inline water analyzer specifically designed as a ‘Turn-Key’ monitoring solution for clean bottled and beverage water applications including bottled Spring and Reverse Osmosis drinking water, beverage manufacturing as well as primary/secondary water supply networks. The DW-2030P series offers highly accurate, real-time measurement, display and data-logging of Ultra-Low Turbidity, Free or Total Chlorine, pH, Conductivity, Total Dissolved Solids and Temperature utilizing proprietary Pyxis Lab smart sensor technology, coupled with a Pyxis touch screen display and data logging terminal. The DW-2030P series is offered in a convenient and easy to integrate panel mounted format for rapid installation and simple maintenance.

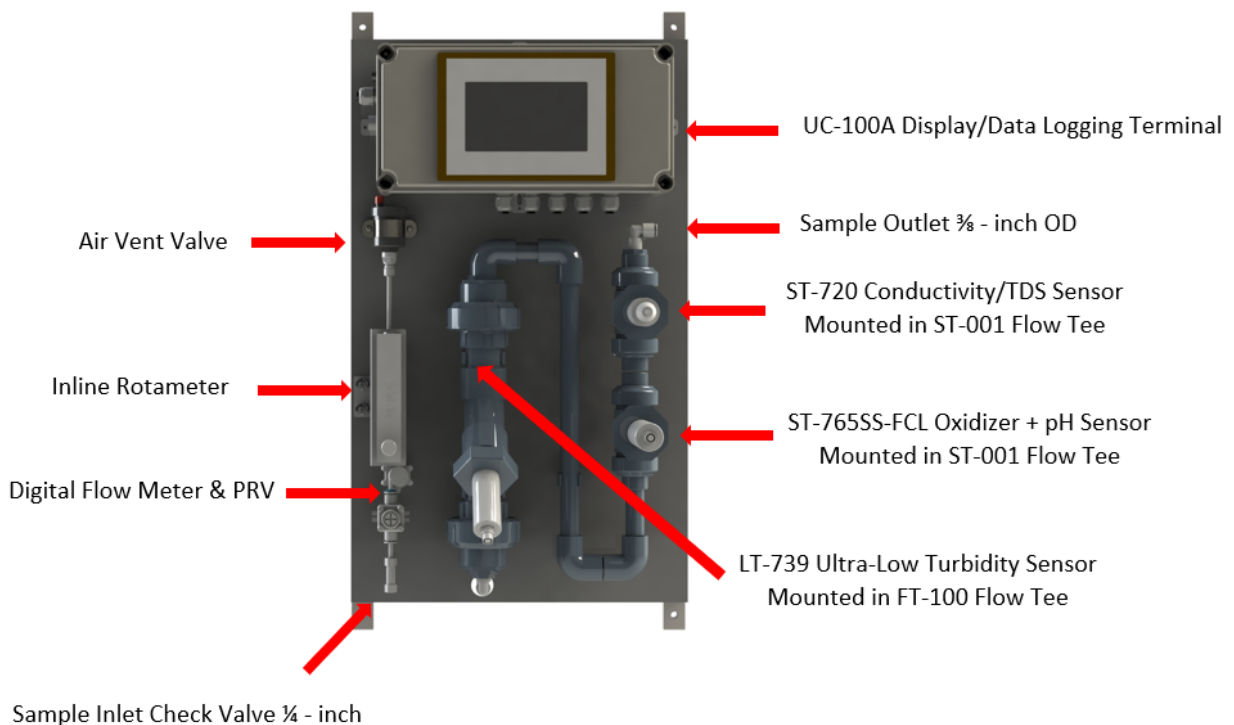

Figure 1 - DW-2030P Series Bottled & Beverage Monitoring Panel

Features

- Pyxis Lab's advanced research and development sensor technologies to achieve highly accurate and stable measurement of Turbidity, Free/Total Chlorine, Conductivity (TDS), pH and Temperature.
- Pyxis LT-739 (EPA) ultra-low resolution turbidity sensors offer a detection light source using warm white LED in 90-degree surface scatter format in accordance with USEPA 180.1 standards. The turbidity sensor is mounted in the unique Pyxis FT-100 flow Tee for reduced footprint while enabling a resolution of 0.002 NTU. The LT-739 offers simple calibration via the Pyxis LT-SOLID-CAL Solid State Turbidity Calibration Kit (no Formazin needed) or the Pyxis L-CAL Portable Liquid Turbidity Calibration Kit (uses 500mL per calibration).
- Pyxis ST-765SS-FCL three-parameter composite sensor is used for the measurement residual free or total chlorine, pH, and temperature in compliance with USEPA 334.0 and ISO-7393 guidelines. The sensors advanced PCB offers built-in temperature and pH parameter compensation (up to pH 9.0+) algorithms eliminating the need for a supplemental pH sensor and controller. Unique Bare-Gold electrode technology for residual chlorine measurement eliminates membranes and electrode solution replenishment commonly associated with conventional sensors. The ST-765SS-FCL has a uniquely designed flat bubble pH electrode design for reduced fouling potential. Reduce your maintenance and cost versus colorimetric chlorine measurement or conventional electrochemical sensors by utilizing Pyxis replaceable Electrode Head (EH-765) for this sensor allowing for years of reliable service. The ST-765SS-FCL may be calibrated in-situ after cleaning via DPD Free or Total Chlorine wet chemistry test measurement of active sample.
- Pyxis ST-720 inline conductivity sensor offers an industrial design with 4-graphite flat surface electrode. This unique design enables superior accuracy, consistency and extended sensor life with limited maintenance and cleaning. The ST-720 also offers integrated RTD temperature compensation and an extended detection range of 1 to 100,000 $\mu\text{S}/\text{cm}$. The sensor reading may be displayed as conductivity or Total Dissolved Solids (TDS) based on user preference and manual programmed conductivity to TDS ratio on the display data logging terminal.
- The inline Pyxis sensors are installed using the uniquely designed ST-001 and FT-100 inline tee assemblies providing a compact design and bottom-up flow ensuring constant sensor flooding. The water sample inlet line contains an integrated PRV, Rotameter, Air Vent Valve and Hall Effect Contact flow meter allowing the users to finely adjust, set and digitally record the bypass flow rate to the recommended flow range of 600–1,000mL/minute. The recommended maximum inlet pressure of DW-2030P Panel is 30psi and discharge should be directed to drain. Sensors are connected to the display/data logger via RS-485 Modbus (RTU) allowing for integrated sensor calibration interface and diagnostics within the display touch screen.
- Convenient and simple to install panel (DW-2030P) for rapid and easy installation. Touch screen display/data logger interface with sensor calibration integrated. Display/data logger offers 2x 4-20mA I/O as well as RS-485 and TCP-IP with remote diagnosis and parameter adjustment. Pyxis CloudLink™ 4G Gateway version available. Integrated "Oxidizer Challenge" feature for periodic verification of sensor performance in applications targeting measurement of Oppm of oxidizer.

4. Dimension and Mounting

DW-2030P Series Panel Dimensions (mm)

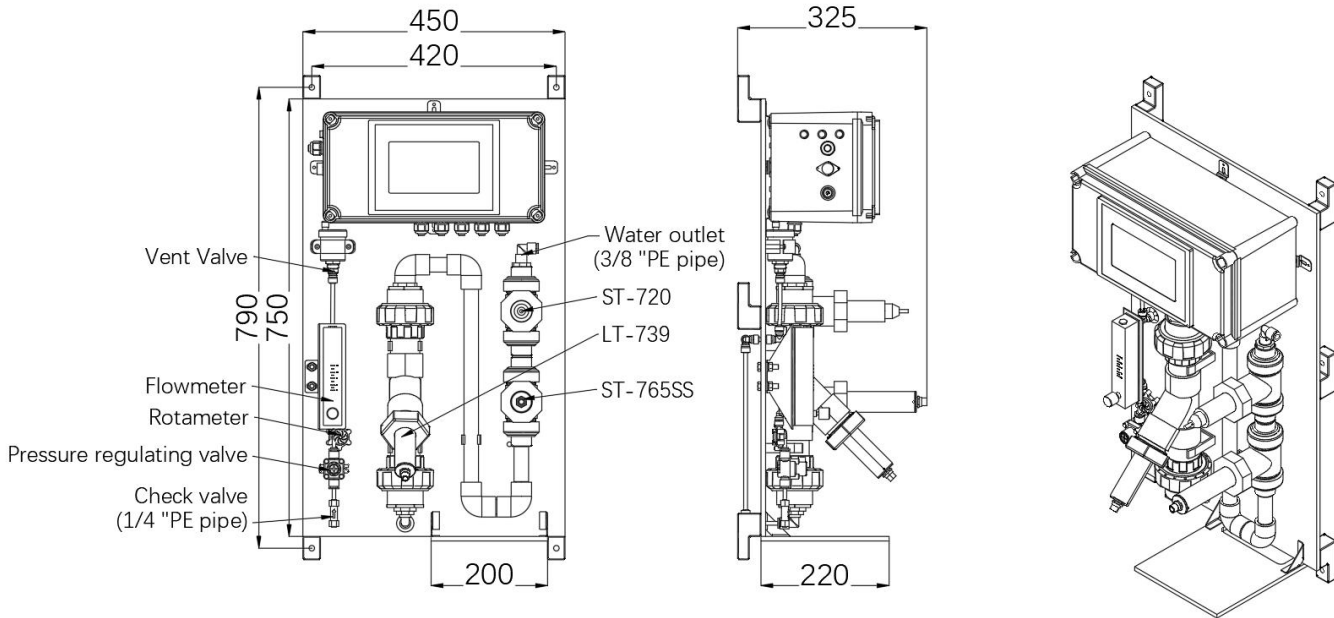

UC-100A Display/Data Logger Dimensions (mm)

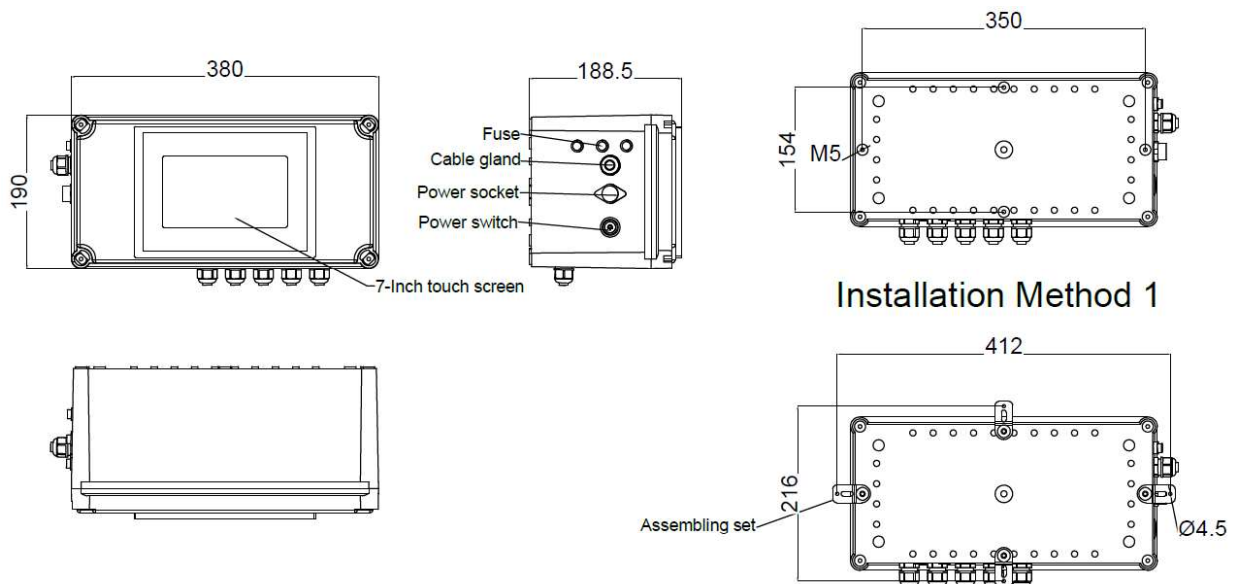

DW-2030P Series Sensor Dimensions (mm)

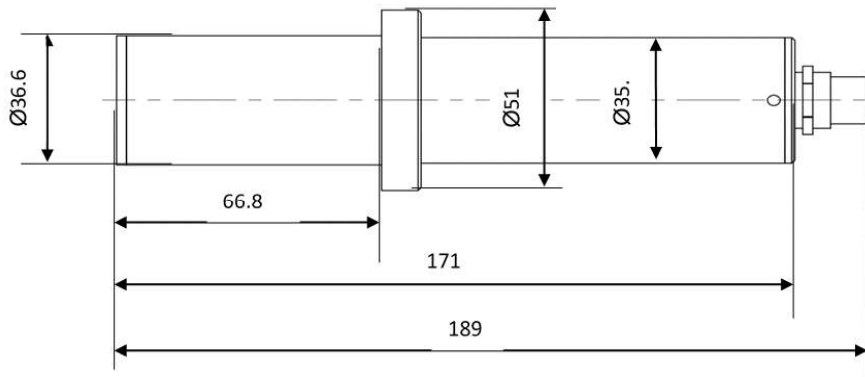

LT-739 Turbidity Sensor

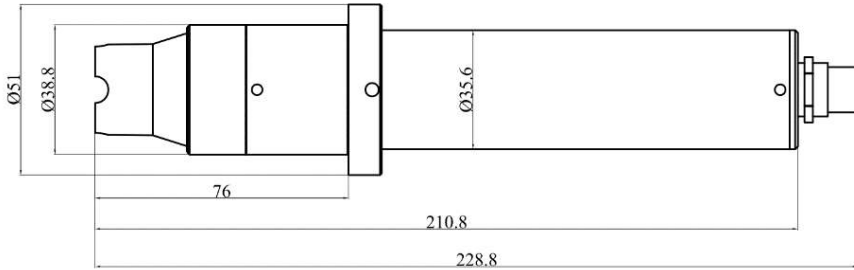

ST-765SS-FCL Free Chlorine + pH Sensor

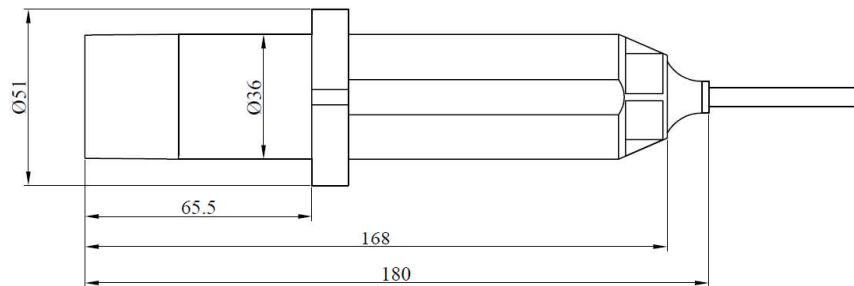

ST-720 Conductivity/TDS Sensor

5. Installation

5.1. Installation Requirements

Power Supply: 100~240V AC 50/60Hz

Sample Water Supply: The inlet water sample pressure should be within 7.25 – 30 psi (0.05-0.2MPa) and the inlet feedwater line is a diameter of ¼-inch OD Tubing. The DW-2030P series panel is shipped with a PRV (Pressure Reducing Valve) as well as Rotameter and Digital Hall Effect Flow Meter/Switch for fine tune flow measurement, recording and adjustment. The recommended flow rate through the DW-2030P series panel is 600 – 1,000 mL/minute. Flow should be set in this range and maintained at consistent inlet pressure levels. Downstream of the rotameter is installed a vent valve assembly allowing for air bubble degasification from the water stream.

Sample Water Outlet: The outlet water sample line diameter is ⅜-inch OD Tubing. This line should both be connected to an atmospheric discharge drain or returned to an open sump or tank of the process for re-use.

Wall Mount Space: The DW-2030P series analyzer panel size is roughly 790H x 450W x 280D (mm) in dimension. Please accommodate sufficient space for mounting.

Wall Mount Weight: Approximately 15kg. Please use appropriate mounting hardware.

3G/4G Network: The DW-2030P-US-G (P/N 42168) comes equipped with a preinstalled Pyxis CloudLink 4G Gateway with antenna for wireless data acquisition and management via Pyxis Cloud. Make sure your mobile network is a CMCC/CUCC 3G/4G compatible network. Ensure the signal strength is sufficient in the installation area.



Figure 1A - CloudLink 4G Gateway available in DW-2030P-US-G only

5.2. Tube Connection

1. **Sample Water Inlet Line:** Connect the ¼-inch OD inlet water tubing to the quick adapter provided.
2. **Sample Water Outlet Line:** Connect the ⅜-inch sample water outlet tubing to the quick adapter provided. As noted above, this line should both be connected to an atmospheric discharge drain or returned to an open sump or tank of the process for re-use.

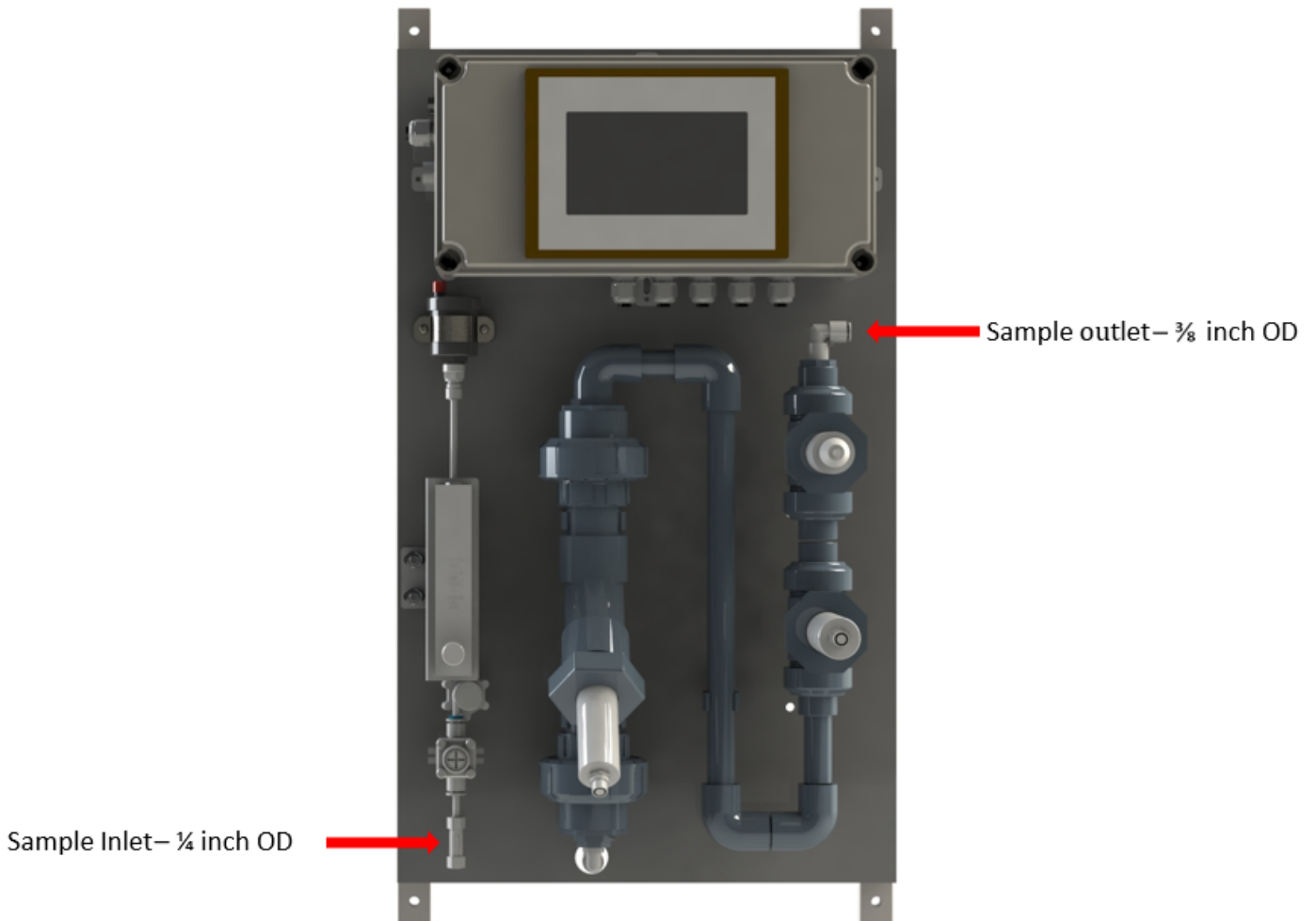

Figure. 2 Water inlet and outlet diagram

6. Touch Screen Operation

6.1. Main Screen

After the system is powered on an initial screen allows the user to log into the system.

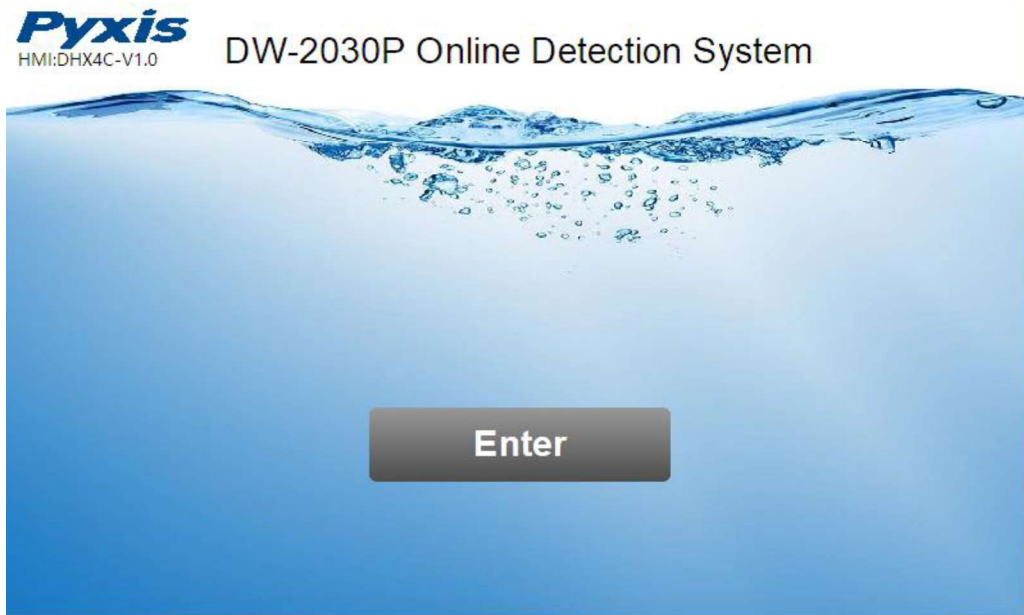

Figure 4 - Main Screen

6.2. User Login

After powering on the system, log in with the username and password to be able to change system settings. Click the "User Login" button, select the user "pyxis", enter the password: "888888" in the user password field. A new user can be added via "User Management" in interface of the menu. If you do not need a password, or want to change the user, you can enter the system and "Manage" in the "User Management" screen of the menu. See 6.11 for details.

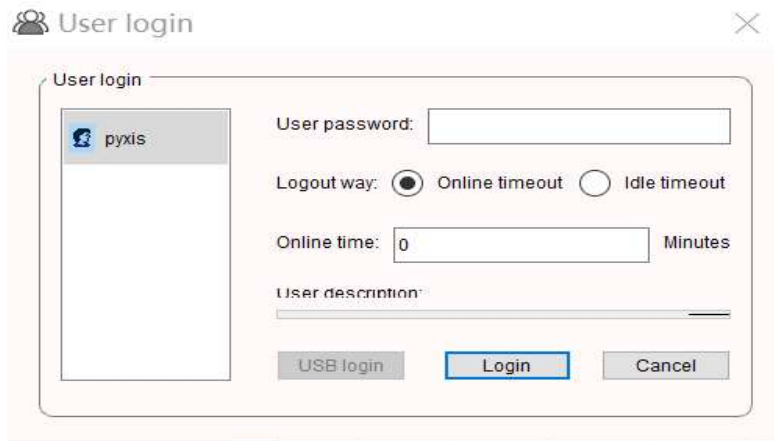

Figure 5 - User Login Screen

6.3. Real-Time Monitoring

Click the "Enter System" button on the main interface to enter the real-time monitoring screen of the system. The data detected by the Pyxis sensors will be displayed in real-time. See a functional overview of each section of this screen highlighted below. (Numbers 1-4)

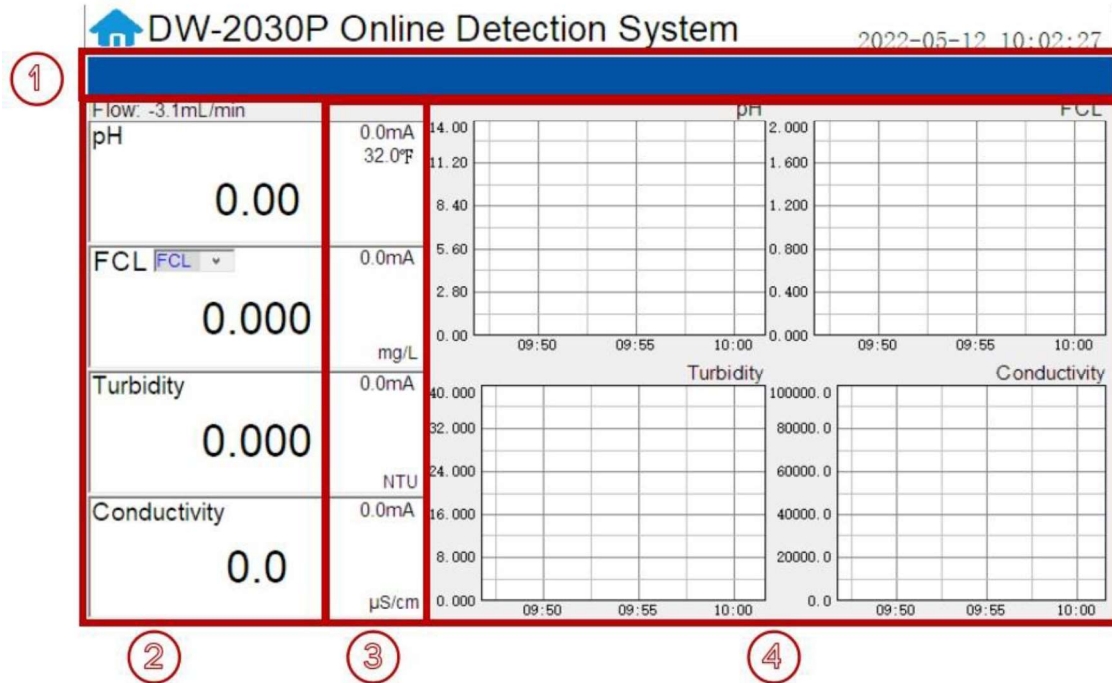

Figure 6 - Real-time monitoring screen

Section Number	Functional Overview
1	The blue area will scroll any alarm information in real time until the alarm is cleared.
2	Real-time display of current sensor measurement value.
3	Real-time display of the current sensor's 4-20mA signal value.
4	Historical data is recorded as a live curve, with the horizontal coordinate being the time and the vertical coordinate being the measured value.

Table 1 - Main interface functional overview

Press and hold the curve area for 2 seconds and then let go, the Y-axis curve range setting dialog box will appear. Users may change the display value range of Y-axis for each measurement index curve. Click the outer area of the screen to save and exit the setting screen after modifications are made.

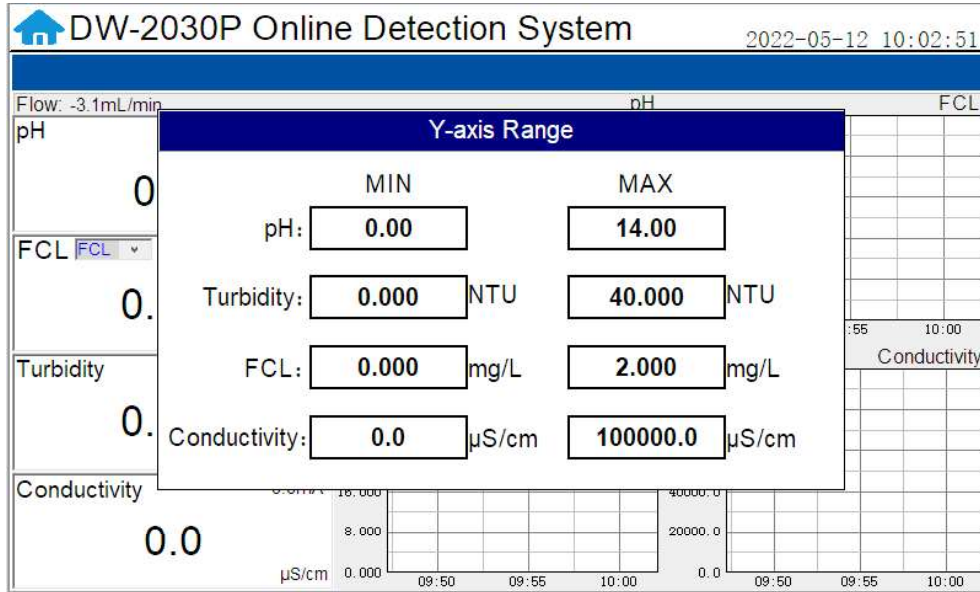



Figure 7 - Curve Range Setting

6.4. Menu Bar

Click the  button in the upper left corner of the screen to enter the system's menu interface, where the user can select to enter the desired operation interface.

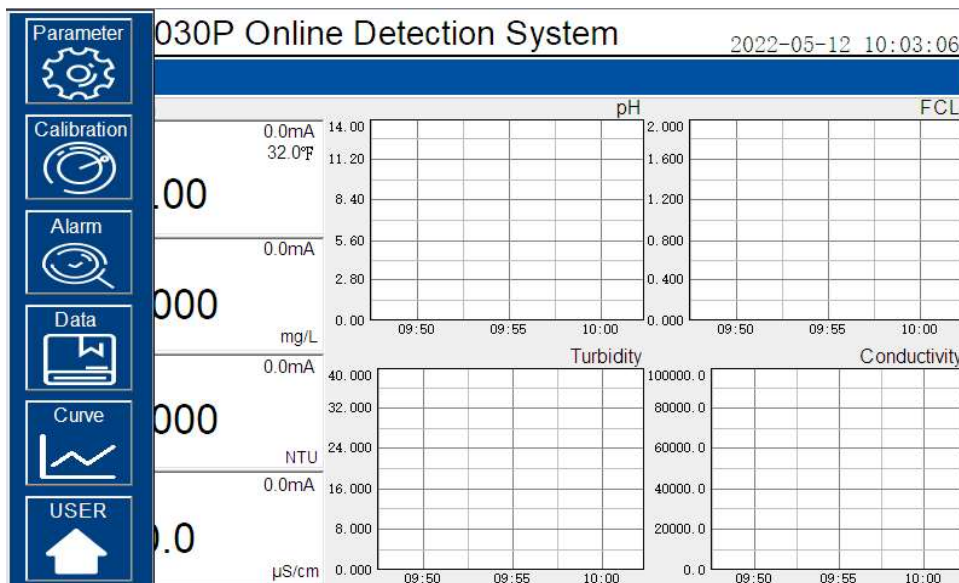

Figure 8 - Menu Bar

6.5. Configurable Parameters

Click the "Parameter" button in the menu bar. Here you can select to enter "Alarm Parameters" and "4-20mA Output" setting interface etc.

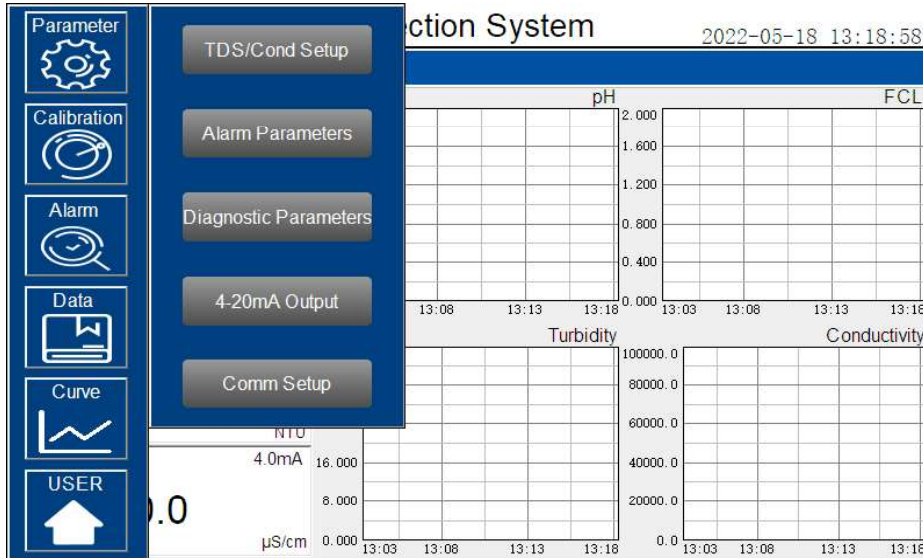

Figure 9 - Parameter Settings

6.5.1. TDS/Conductivity Setup

Click "TDS/Cond Setup" to enter the setup interface, where TDS (Total Dissolved Solids) or Conductivity may be user selected according to application needs. When TDS is the selected display, the conductivity conversion factor can be user set based on the desired conversion ratio. A Conductivity to TDS conversion ratio of 0.67 will be preprogrammed as the default.

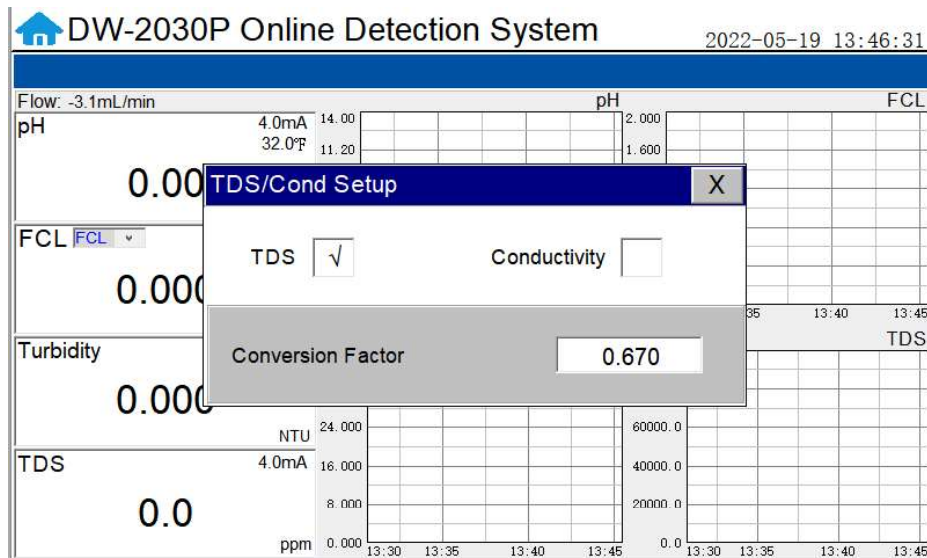

Figure 10 – TDS / Conductivity Setup

6.5.2. Alarm Parameters Setting

Users can set the upper and lower alarm limits. Click "Alarm Parameters" to enter the alarm parameter settings. When the measured sensor value is lower than the set lower limit (the XX lower limit alarm) or when the measured value is higher than the set upper limit (the XX upper limit alarm), the corresponding sensor alarm will be displayed on the real-time monitoring screen. The user can also choose to turn the alarm display on or off at the top left of the corresponding parameter list.

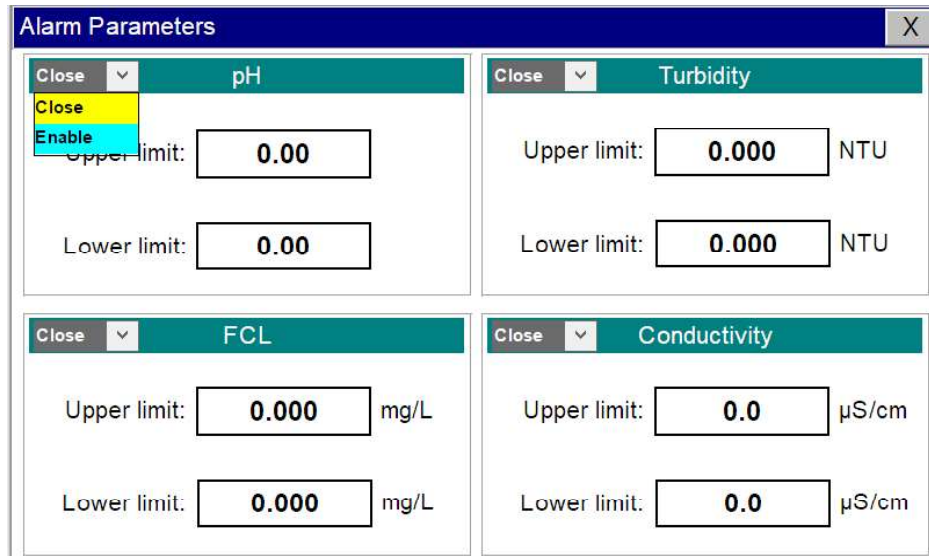

Figure 11 - Alarm Parameter Setting

6.5.3. Diagnostic Parameters

Click "Diagnosis Parameters" to the diagnosis page. In the diagnosis page, the raw data measured by the probe is displayed. To help troubleshooting possible issues with the probe, please save an image of this data when the probe is placed in a clean water (tap water or deionized water), in a standard, and in the sample that the probe is intended for.

Diagnostic Parameters			
FCL			
It_WorkCurrentnA:	0.000nA	pH_Voltage:	0.000V
RTDValue:	0.000Ω	Offset:	0.000
ORP:	0.000mV	VCount:	0.000mV
Turbidity			
s365DiLow:	0.000	s365DiHigh:	0.000
s365Low:	0	s365High:	0
intercept:	0.000	SlopeLow:	0.000
SlopeHigh:	0.000	dark:	0
t365:	0		
Conductivity			
rtemp:	0.000	Cond_Vi:	0.000
Cond_Vv:	0.000	RG:	0
RES_SELECT:	0	k:	0.000
smoothingfactor:	0.000		

Figure 12 - Diagnostic Parameters

6.5.4. 4-20mA Output Parameters Setting

Click "4-20mA Output " to enter the 4-20mA output parameter setting interface. The 4mA and 20mA output values should corresponds to the lower and upper limits of the sensor range. ***NOTE*** The closer the value is set to the measurement value the more accurate the data. It is recommended to set according to the range of the sensor.

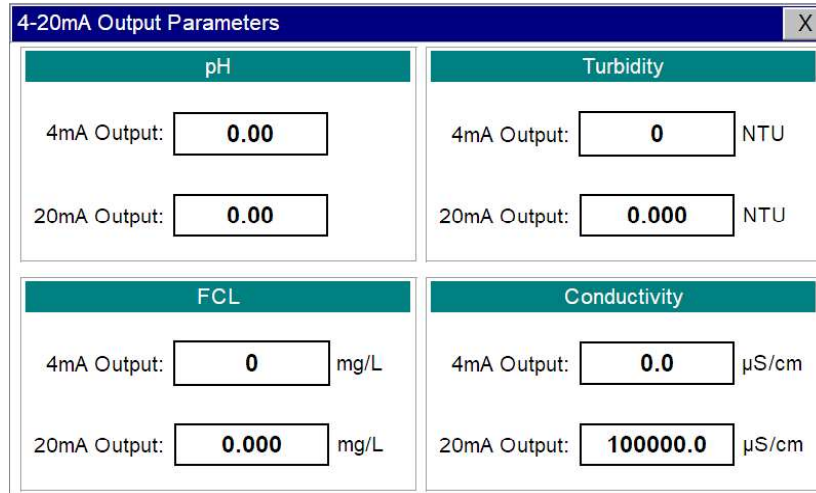

Figure 13 - 4-20mA Output Setting

6.5.5. Communication Setting

Communication parameters generally do not need to be changed. If the communication station number and other parameters need to be changed on site, they can be changed on this interface.

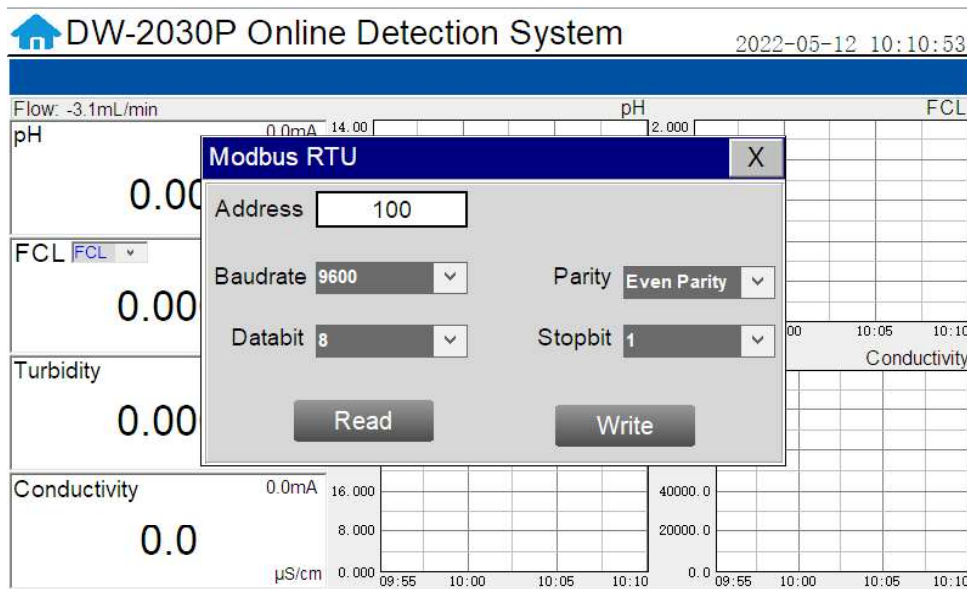

Figure 14 - Modbus RTU

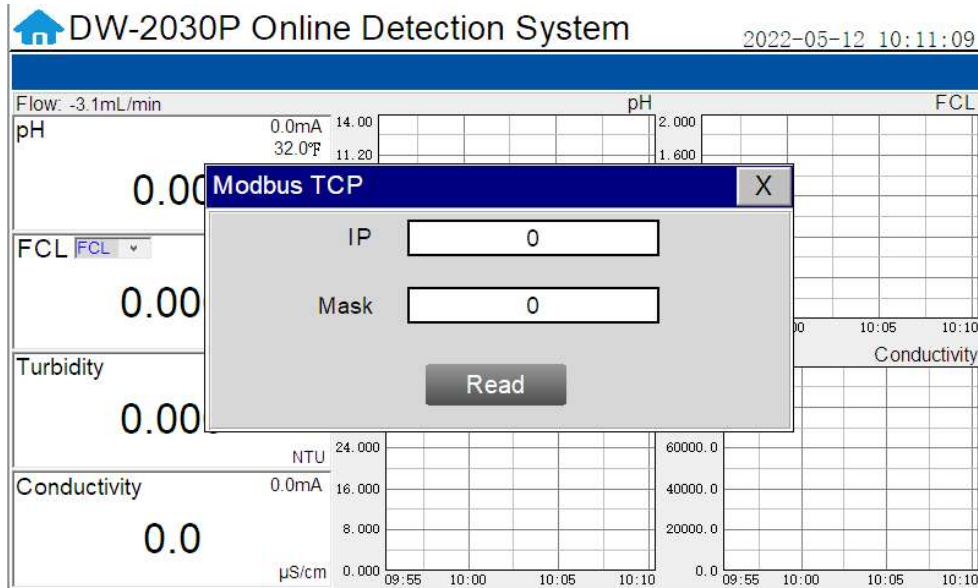

Figure 15 - Modbus TCP

6.6. Calibration

Click on the "Calibration" button in the menu bar and select the sensor to be calibrated.

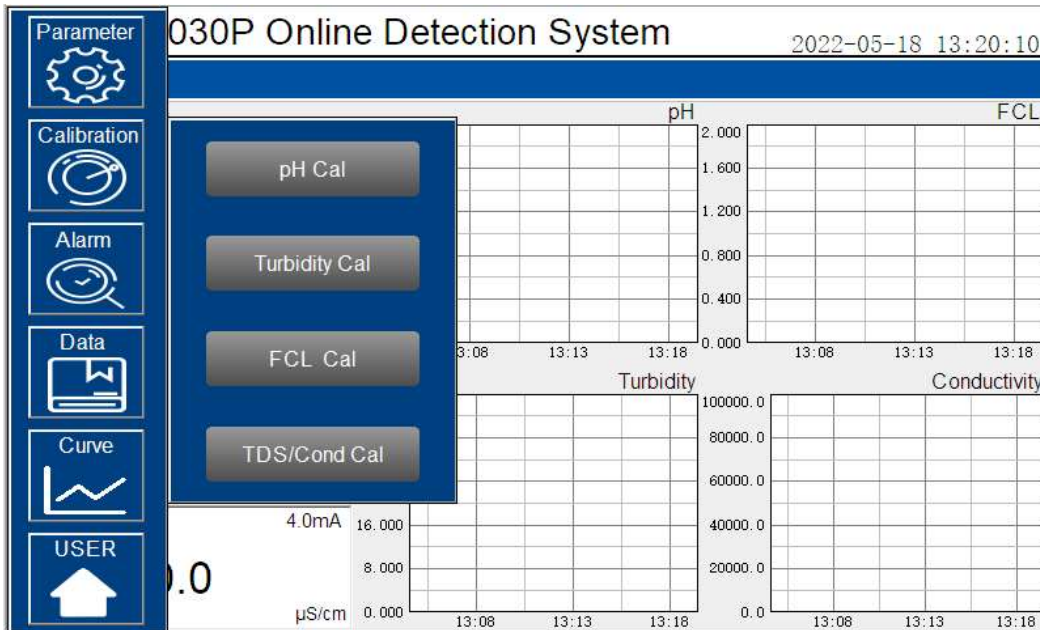

Figure 16 - Sensor Calibration

6.6.1. pH Calibration

The pH function is thoroughly calibrated at the Pyxis Lab factory. After checking with a pH standard buffer solution, if the sensor value has shifted, then the user may choose from single-point, two-point or three-point calibration to re-calibrate the pH portion of the ST-765SS-FCL sensor as desired.

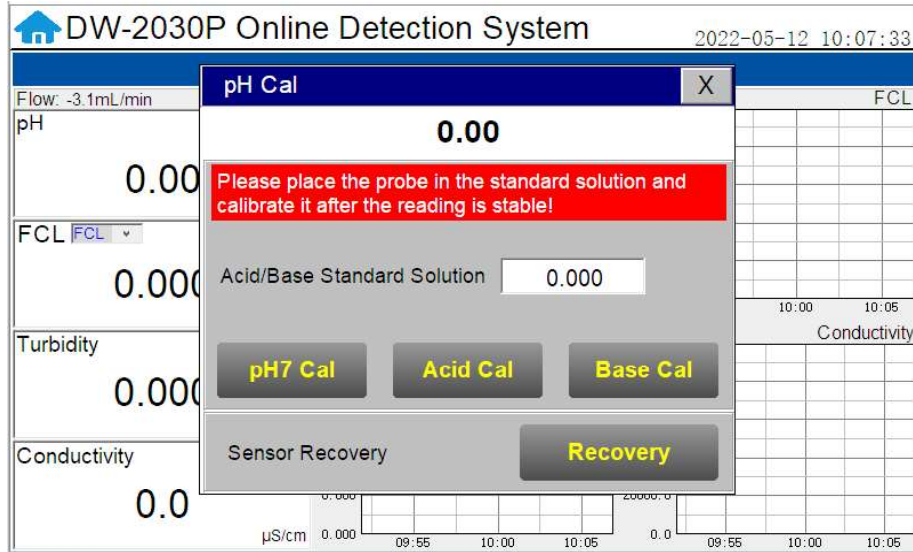

Figure 17 - pH Calibration

Single Point pH Calibration

Remove the ST-765SS Series sensor and rinse 3x with DI water. Submerge the sensor into a beaker with pH=7 buffer solution. Click "pH7 calibration". A dialog box will pop up to confirm whether to perform this operation, click "OK" if the calibration operation is confirmed, if the calibration is successful the dialog box will show "calibration success".

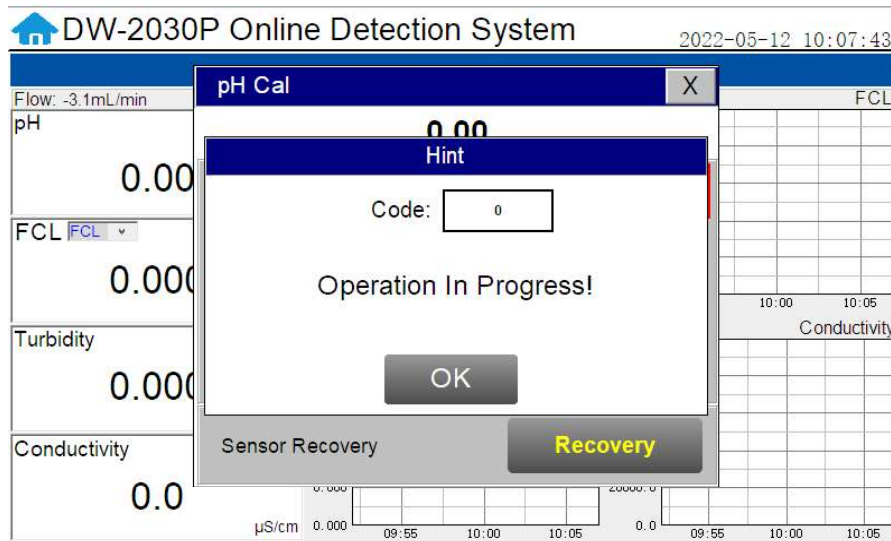

Figure 18 - pH Calibration Success Prompt

Two Point pH Calibration

Remove the ST-765SS Series sensor and rinse 3x with DI water. Submerge the sensor into a beaker with pH=7 buffer solution. Click "pH7 calibration". A dialog box will pop up to confirm whether to perform this operation, click "OK" if the calibration operation is confirmed, if the calibration is successful the dialog box will show "calibration success".

After pH7 is successfully calibrated, you can choose acid calibration or alkali calibration for the second calibration point. If you choose acid calibration, clean beaker 3x with deionized water. Fill the beaker with pH=4 buffer solution. Enter the value 4 in the calibration value dialog box, and click "Acid Calibration", then a dialog box will pop up to confirm whether to perform this operation. Click "OK" if the calibration operation is confirmed and the dialog box will show "Calibration Successful" if the calibration is successful. Similarly a pH=10 buffer solution can be selected for the second point calibration if desired.



Figure 19A - pH Calibration Value Input

Three Point pH Calibration

Remove the ST-765SS Series sensor and rinse 3x with DI water. Submerge the sensor into a beaker with pH=7 buffer solution. Click "pH7 calibration". A dialog box will pop up to confirm whether to perform this operation, click "OK" if the calibration operation is confirmed, if the calibration is successful the dialog box will show "calibration success".

After pH7 is successfully calibrated, you can choose acid calibration or alkali calibration for the second calibration point. If you choose acid calibration, clean the beaker 3x with deionized water. Fill the beaker with pH=4 buffer solution. Enter the value 4 in the calibration value dialog box, and click "Acid Calibration", then a dialog box will pop up to confirm whether to perform this operation. Click "OK" if the calibration operation is confirmed and the dialog box will show "Calibration Successful" if the calibration is successful.

After successful acid calibration, select pH=10 for alkali calibration. Clean the beaker 3x with deionized water. Fill the beaker with pH=10 buffer solution. Enter the value 10 in the calibration value dialog box, and click "Alkali Calibration", then a dialog box will pop up to confirm whether to perform this operation. Click "OK" if the calibration operation is confirmed and the dialog box will show "Calibration Successful" if the calibration is successful. The three-point calibration is completed.

6.6.2. Turbidity Calibration using L-CAL Portable Calibration Kit

The LT-739 Ultra Low Turbidity Sensor is rigorously calibrated at the Pyxis Lab factory. If the sensor is kept clean, the user will not need to calibrate the sensor for one year of operation. However, the user may calibrate the sensor as desired.

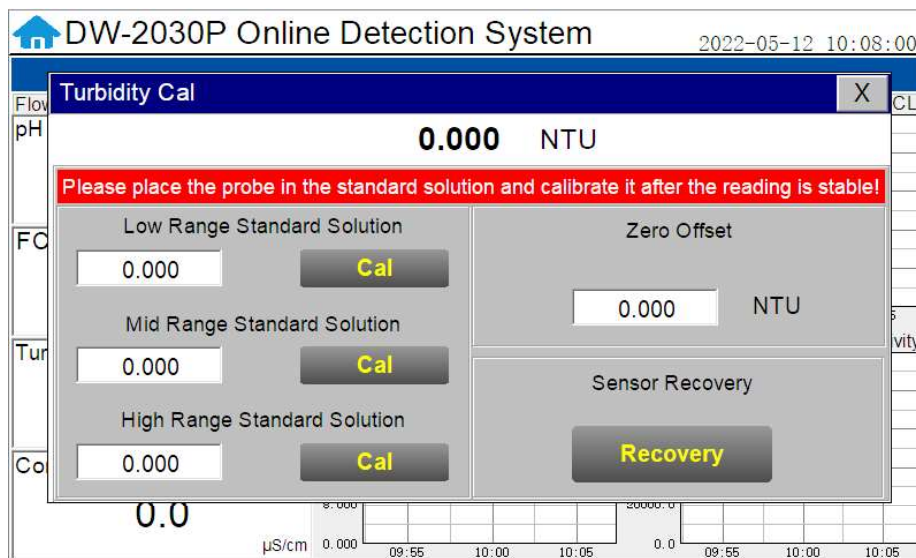

Figure 20 - Turbidity Calibration Screen

Low-Range Calibration Procedure DI Water in the Pyxis L-CAL Portable Turbidity Calibration Kit:

Isolate the panel and drain the piping and inline Tee assemblies. Remove the LT-739 sensor from the FT-100 flow tee. Triple rinse the LT-739 sensor surface, the FT-100 flow tee internals, and the L-CAL Portable Turbidity Calibration Kit (P/N 53247) vessel with Deionized water. Insert the cleaned LT-739 turbidity sensor into the L-CAL calibration vessel and position the L-CAL vessel vertically (with the sensor inserted in a horizontal position to the ground as shown in the step-by-step images provided on page 21 of this manual). Remove the top cap and fill the L-CAL vessel with 500mL of bubble free deionized water. After the displayed turbidity data is stable, enter "0.05" for the low-range calibration value and click on "Low Range Calibration", a dialog box will pop up to confirm whether to perform this operation. Click "OK", if the calibration is successful, the dialog box will show "Calibration successful". ***NOTE*** Because there is no global standard for zero turbidity in the industry, Pyxis recommends 0.05 NTU as a target for Low-Point Calibration while using Bubble-Free DI Water.

Mid-Range Calibration using the L-CAL Portable Turbidity Calibration Kit:

After the low range calibration has been completed, rinse the L-CAL vessel with Deionized water and refill with 500mL of known turbidity standard solution between 5NTU and 10NTU for mid-range calibration (see page 21). After the displayed data is stable, enter the medium turbidity standard solution value and click on "Mid-Range Calibration", a dialog box will pop up to confirm whether to perform this operation. Click "OK", if the calibration is successful, the dialog box will show "Calibration successful".

High-Range Calibration using the L-CAL Portable Turbidity Calibration Kit:

If a high-range calibration is not required, the user does not need to perform a high-range calibration of the LT-739 series sensor. If a high calibration is required, proceed by rinsing the L-CAL vessel with deionized water and refill with known turbidity standard solution between 20NTU and 40NTU for high-range calibration (see page 21). After the displayed data is stable, enter the high turbidity standard solution value and click on "High Range Calibration", a dialog box will pop up to confirm whether to perform this operation. Click "OK", if the calibration is successful, the dialog box will show "Calibration successful".

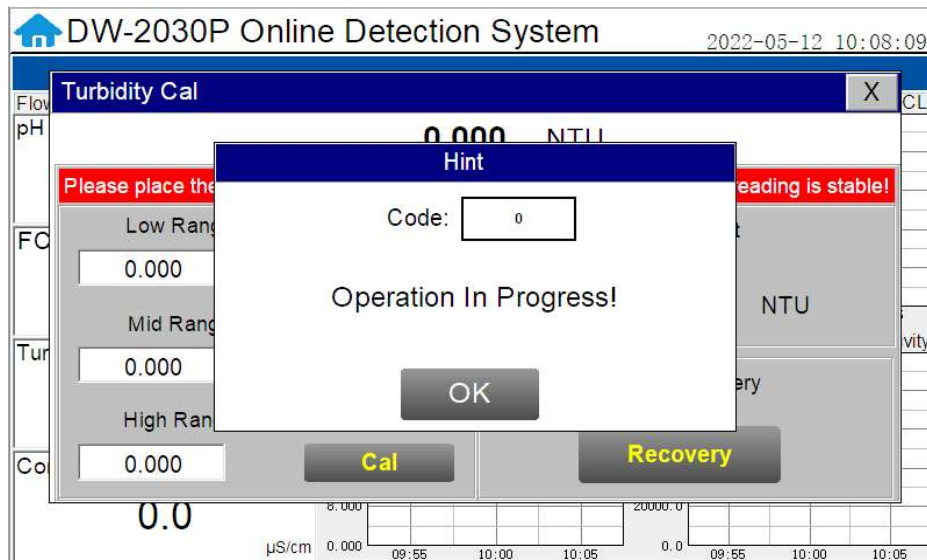

Figure 21 - Awaiting execution Screen of Turbidity Calibration

Troubleshooting Calibration Failed Messages

If you receive a "Calibration Fails" message during the calibration steps above, the following items should be checked:

- 1) Ensure your source of Deionized water is not contaminated with turbidity
- 2) Ensure your turbidity calibration standard solutions have not been contaminated
- 3) Ensure the LT-739 sensor distillate end is not contaminated with debris or other substances

LT-739 Calibration using L-CAL Portable Turbidity Calibration Kit

Pyxis Lab has developed a portable and reusable liquid-state turbidity calibration kit for rapid calibration of the all LT-73X Series inline ultra-low turbidity sensors. The L-CAL calibration kit allows users to calibrate all LT-73X Series ultra-low turbidity sensors using smaller volumes of Formazin turbidity calibration standards providing an affordable and reusable solution for long term sensor reliability. The unique design of the L-CAL liquid calibration kit allows the LT-73X sensor to be easily inserted and calibrated with the sensor in a horizontal position, allowing air bubbles to be evacuated through the integrated air-vent line ensuring superior accuracy of the sensor calibration. The L-CAL has an easy to remove lid allowing users to fill and empty the calibration kit with DI water for vessel/sensor cleaning and Formazin calibration standards for sensor calibration.



L-CAL Liquid Turbidity Calibration Kit (P/N 53247)

Turbidity Calibration Principals & Considerations

The precision, resolution and the low detection limit of the LT-73X Series sensors are not affected by the calibration method, regardless of using certified Formazin standards and the L-CAL kit. The calibration only affects the turbidity sensor accuracy. The nature of turbidity measurement makes an absolute turbidity value not easily obtainable for any sensor manufacturer although proper standards and methods are followed. For example, turbidity values greater than 1.0 NTU measured on real-world samples with different sensors, even from the single manufacturer, could differ significantly. For ultra-low turbidity (less than 0.3 NTU) measurement using the same methods (ISO-7027 or EPA-180.1), it is likely that the values from different sensors can agree within 0.05 NTU. As such, the user should choose a calibration method and remain with the same calibration method for consistency.

L-CAL Specifications

Item	L-CAL Portable Liquid Formazin Calibration Kit
P/N	53247
Sensor Name	LT-739
Calibration	Recommended Calibration Standard Solution Range
Low-Range (0.05NTU Recommended for Calibration)	Bubble Free DI Water or Sample <0.1 NTU
Mid-Range	5 – 10 NTU
High-Range	20 – 40 NTU

L-CAL Portable Liquid Formazin Calibration Kit Use Method

After removing the LT-73X sensor, gently wipe off the flat distal end with a soft cloth to ensure it is clean. The LT-73X Sensor should then be calibrated using the L-CAL portable liquid calibration kit using the following steps, and wirelessly calibrated via the uPyxis Mobile or Desktop APP. Please refer to LT-73X Series Operation Manual for details.

Insert LT-73X Sensor



Tighten Sensor Nut



Position Vertically and Remove Lid



Preclean by adding DI-Water (200mL)



Insert Lid



Gently Shake Then Empty Contents



Add Calibration Standard (500mL)



Insert Lid and Remove Air Bubble Vent Line Cap



FOLLOW
CALIBRATION
STEPS

**NOTE* Sensor Brace Included with L-CAL Kit for Stability*



WATCH PROCEDURE VIDEO <https://www.youtube.com/watch?v=1MuJM5Q5VB4>

6.6.3. Chlorine Calibration

The residual chlorine measurement module of the ST-765SS-FCL sensor is thoroughly calibrated at the Pyxis Lab factory. To calibrate, the user can perform a single-point or two-point calibration according to the requirements of the application. (USEPA-334.0 / ISO-7393 compliant methodology)

Single Point Chlorine Calibration

Use a portable or laboratory colorimeter (i.e.. Pyxis SP-200 / SP-800 / SP-910) to test the active (flowing) water sample in the flow tee assembly. DPD wet chemistry methodology is recommended. Once you have tested and confirmed the residual chlorine concentration value in the active (flowing) flow tee assembly, enter the test result value of the portable or laboratory colorimeter in FCL Calibration Screen and click "High Point Calibration". A dialog box will pop up to confirm whether to perform this operation. If the calibration operation is confirmed, click "OK", and if the calibration is successful, the dialog box will show "Calibration Success".

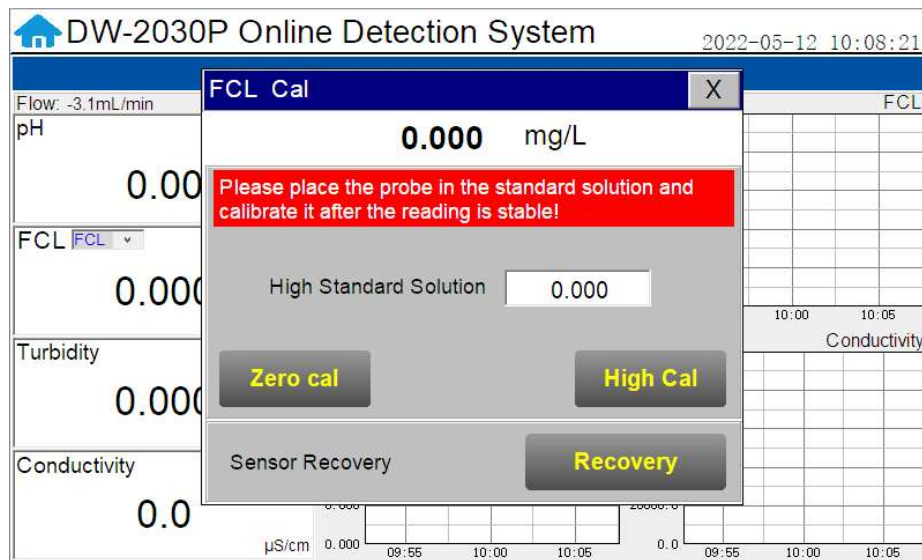

Figure 22 - Chlorine Calibration

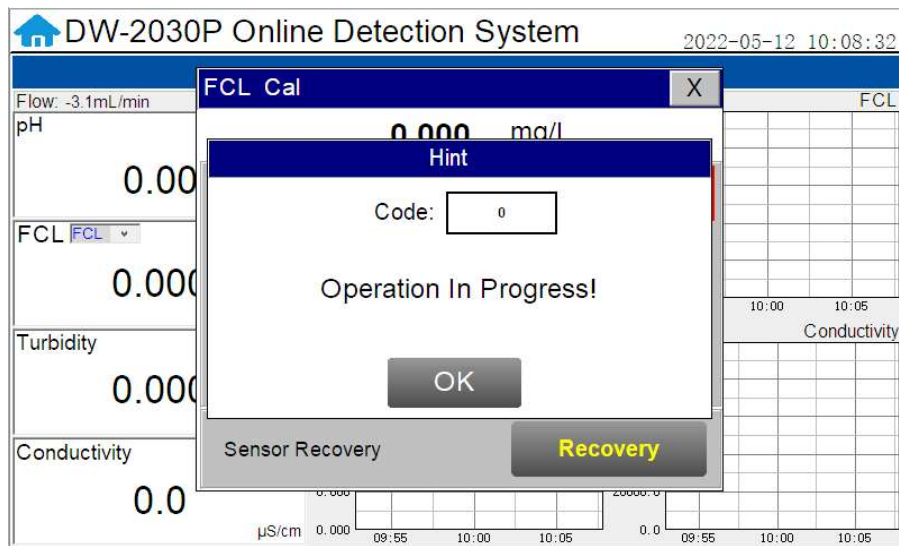

Figure 23 - Awaiting execution Screen of Chlorine Calibration

Two Point Chlorine Calibration

The intercept in the ST-765SS-FCL sensor residual chlorine concentration formula is non-zero from the Pyxis Lab factory, however the user can prepare a blank calibration to correct the intercept in the residual chlorine concentration formula according to application needs.

Blank Calibration Procedure:

To achieve blank calibration of the ST-765SS-FCL sensor, close the water inlet valve, remove the ST-765SS-FCL sensor and gently rinse sensor electrode with deionized water 2-3 times. Install the sensor into a beaker with the known zero calibration solution (P/N 21068) or Conductivity Standard Solution (100 uS/cm), wait for the ST-765SS-FCL sensor residual chlorine value to stabilize on the touch-screen display. Sensor stabilization should occur within 15-minutes. Click "Zero Calibration" and a dialog box will pop up confirm whether your desire to perform this operation. Click "OK" to confirm the calibration operation. If the calibration is successful, the dialog box will show "Calibration Success". The sensor is now blank-calibrated to the known zero calibration solution.

Slope Calibration Procedure:

Use a portable or laboratory colorimeter to test the active (flowing) water sample in the flow tee assemblies. DPD wet chemistry methodology is recommended. Once you have tested and confirmed the residual chlorine concentration value in the active (flowing) flow reservoir, enter the test result value of the portable or laboratory colorimeter in FCL Calibration Screen and click "High Point Calibration". A dialog box will pop up to confirm whether to perform this operation. If the calibration operation is confirmed, click "OK", and if the calibration is successful, the dialog box will show "Calibration Success".

6.6.4. TDS/Conductivity Calibration

The TDS/conductivity sensor only needs to be calibrated once, put the sensor into the standard solution with known conductivity standard solution value, enter the standard solution value in the interface, then click calibration, wait for the calibration completion prompt to pop up, which means the calibration is successful.

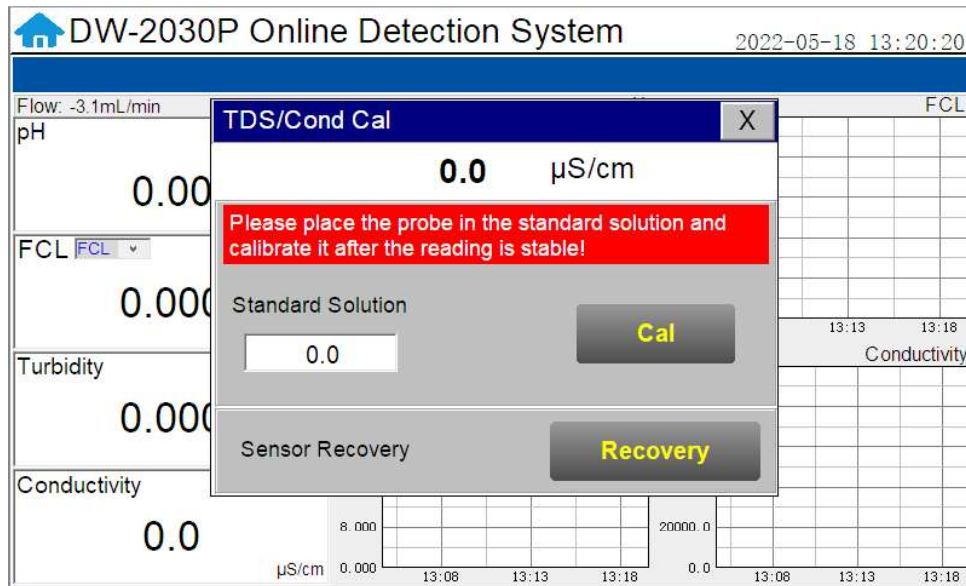

Figure 24 - Conductivity Calibration

6.7. Recovering Data

Click the restore button in the calibration interface of each sensor to restore the data of pH/chlorine sensor, turbidity sensor and conductivity sensor. If a user error is made during calibration and other operations, you may restore the factory settings of the sensor through the restore function.



Figure 25 - Data Recovery Screen

6.8. Alarm View

Click the "Alarm View" button on the main screen to enter the alarm view screen.

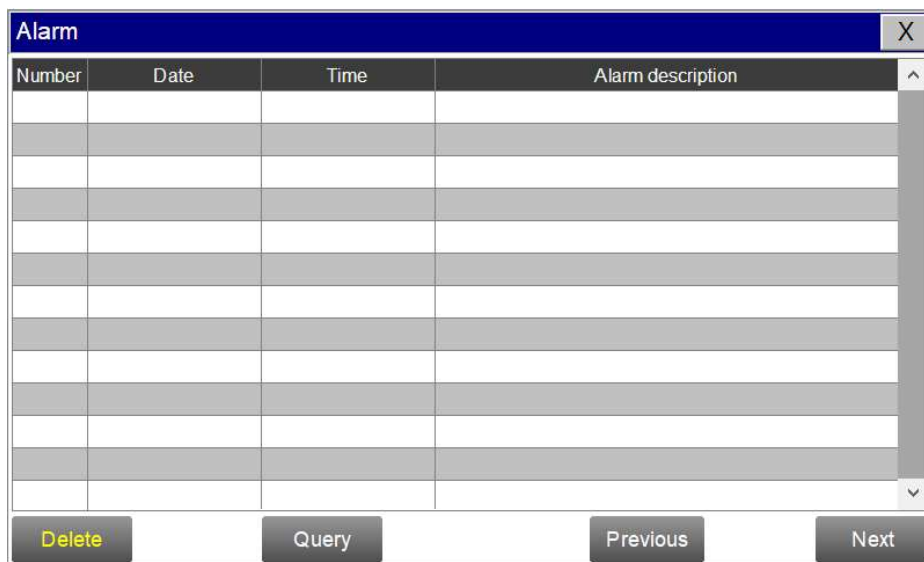

Figure 26 - Alarm View

In this screen users can browse all logged alarms. Drag the right scroll bar up and down to view the history of alarms. Click "Previous" and "Next" to advance to the next page. Click "Query" then enter the alarm number in the pop-up box to query that alarm.

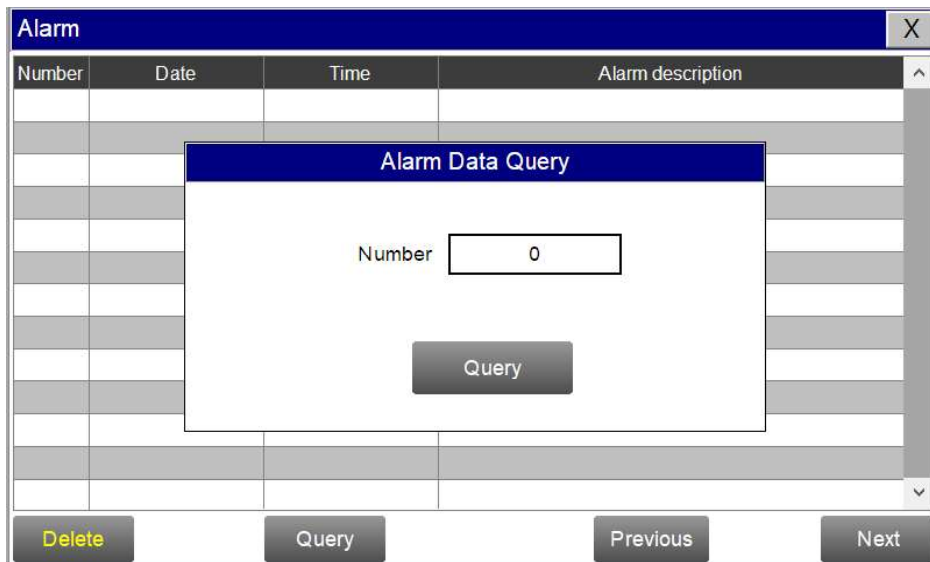

Figure 27 - Alarm Data Query Screen

The Delete button in the lower left corner will delete all alarm records. After clicking delete, you must exit the screen and reenter before the historical data within the data report will be cleared.

6.9. Historical Data

Click the "Historical Data" button in the menu bar to enter the data report interface.



Figure 28 - Historical Data Screen

In the data report, the user can view the stored data of all parameters. The system records sensor readings every 4 seconds by default but this can be edited by the user if desired. Drag the scroll bar on the right to slide up or down or click "Previous" and "Next" to view historical data records. The data

record can save up to 100,000 data entries. New data will overwrite the previously saved data after recording 100,000 data entries. The user can click the “Periodicity” button to change the data recording time interval.

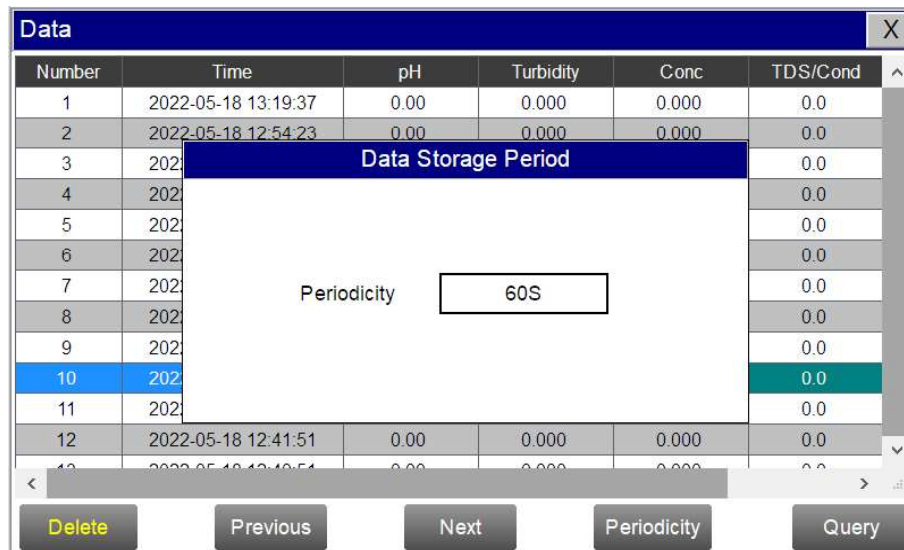

Figure 29 - Data Storage Cycle Time Setting

Click “Delete” in the lower left corner. After entering the retention time, click the “Delete” button to clear all historical data within the retention time range.

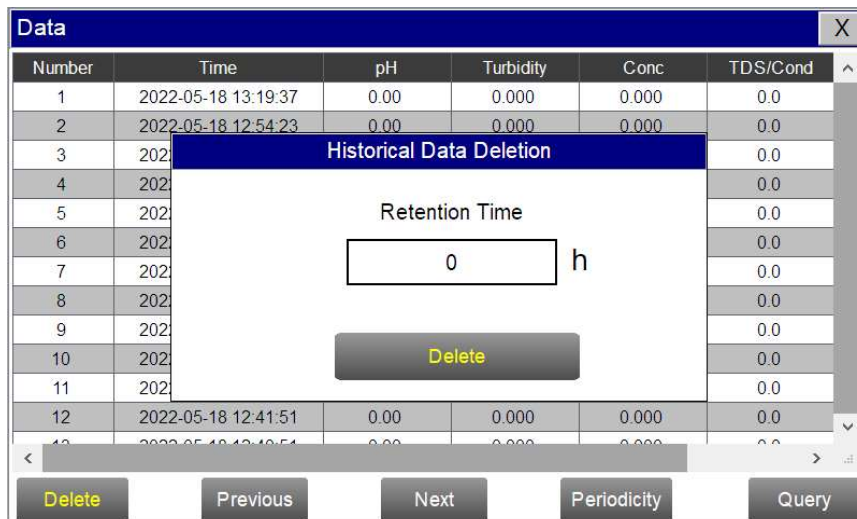

Figure 30 - History Data Deletion Screen

Click the “Query” button in the lower right corner, enter the start time and end time and then click the “Query” button. Note that the start time and end time must be filled in exactly and completely according to the system time format.

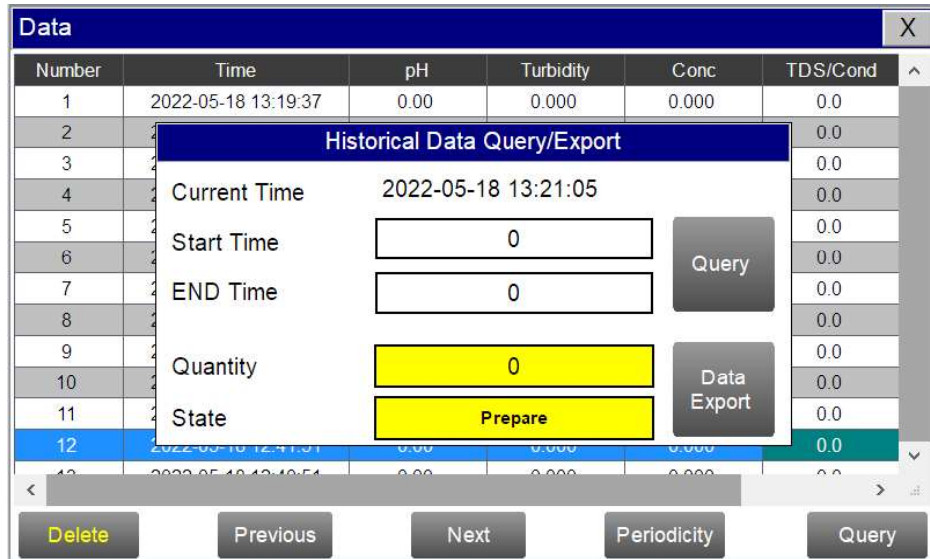

Figure 31 - Historical Data Query and Export Screen

Insert a USB disk behind the display screen and enter the time range of the data to be exported in the query area. Click on the "Data Export" to download the data to the USB disk. The data quantity will be shown as a positive number if data export is successful. If the data export was not successful, please check whether the time format is correct.

6.10. Historical Data Curves

Click the "Historical Curve" button in the menu bar to enter the trend curve interface. You can click the buttons below the X-axis to browse and view the values in a different time range. Click on Y-axis Range to change the minimum and maximum Y-axis values for a proper range.

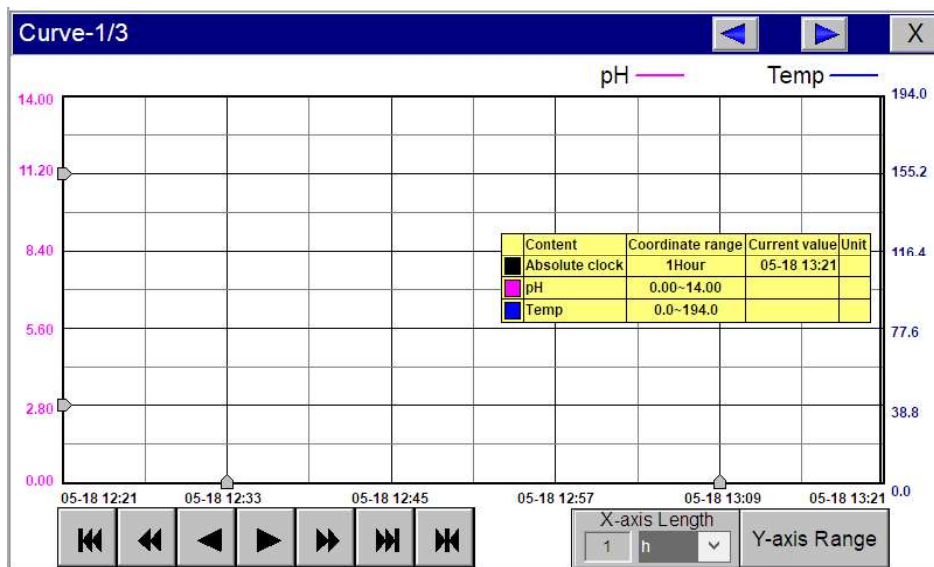

Figure 32 - History Curve Screen

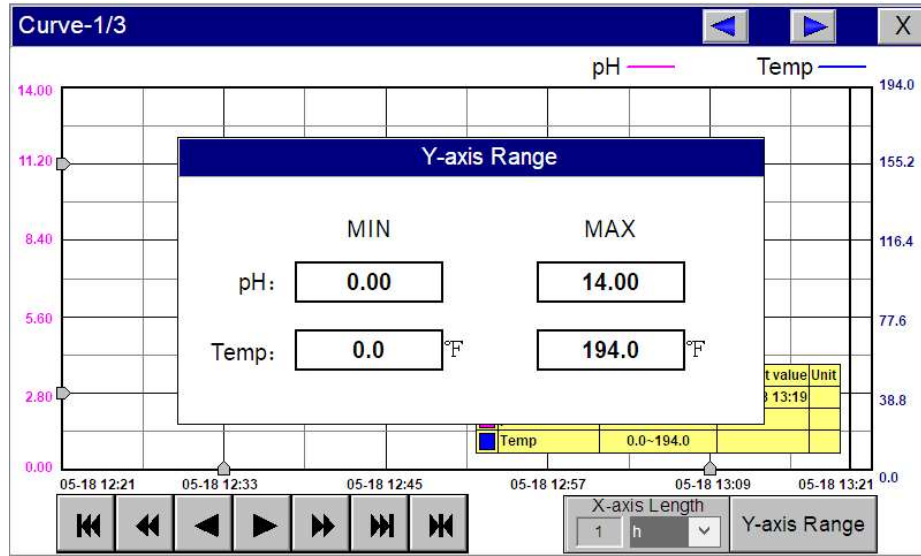

Figure 33 - Y-axis Range Setting

- The curve will scroll back (to the left of the X-axis) one page
- The curve will scroll back (to the left of the X-axis) half the page of the curve
- The curve will scroll backward (to the left of the X-axis) to a position where the main line is drawn
- The curve will scroll forward (to the right of the X-axis) to a position where the main line is drawn
- The curve will scroll forward (to the right of the X-axis) half the page of the curve
- The curve will scroll forward (to the right of the X-axis) one page
- A dialog box will pop up to reset the starting time of the curve

Figure 34 - Button Function Review

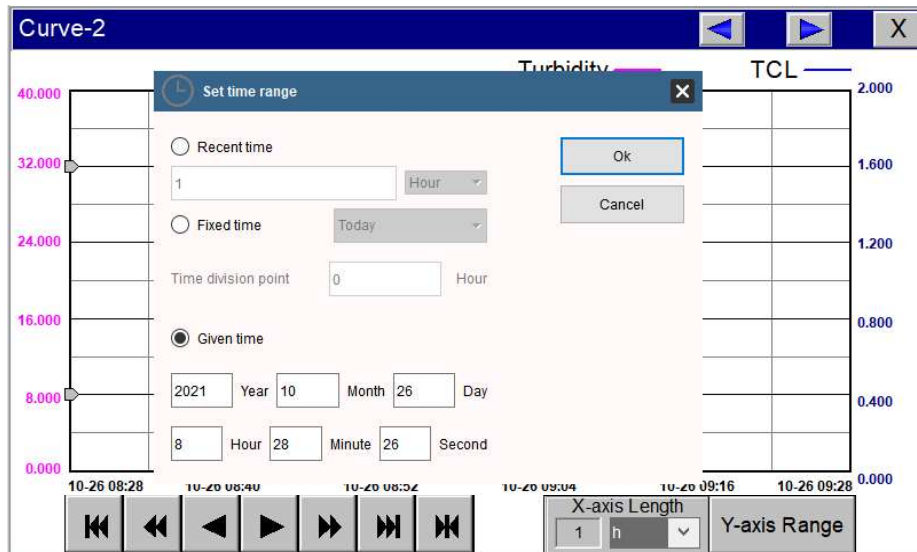

Figure 35 - Time Setting Screen

6.11. User Management

Click the "User Management" button on the menu bar and then you can select "Login", "Logout" and "Manage" operations.

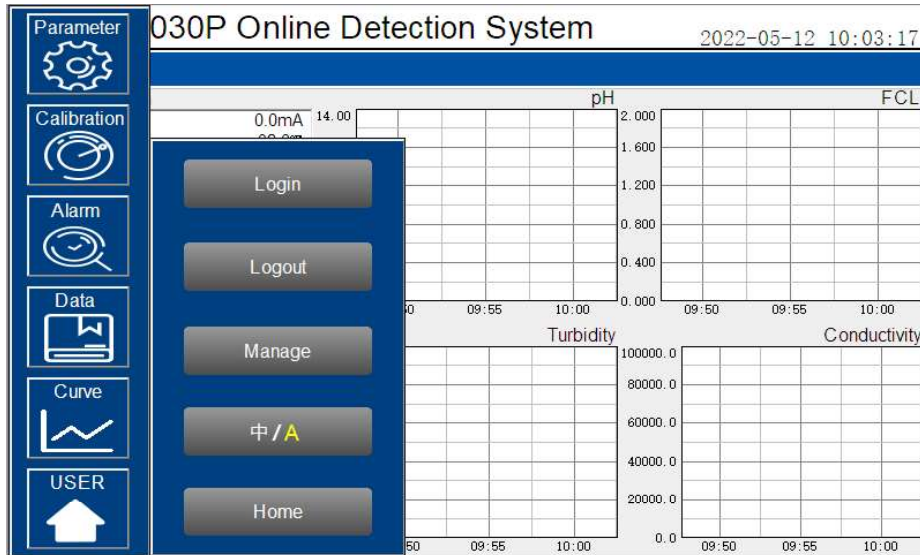

Figure 36 - User Management

Logout enables the user to log out of the logged-in state and only view the real-time readings but cannot perform operations such as parameter settings. Click "Manage" to enter the user management interface, where you can add users, change passwords and other operations. Users can set their own username and password and select the user group they belong to. Only users in the administrator group can set parameters such as calibration.

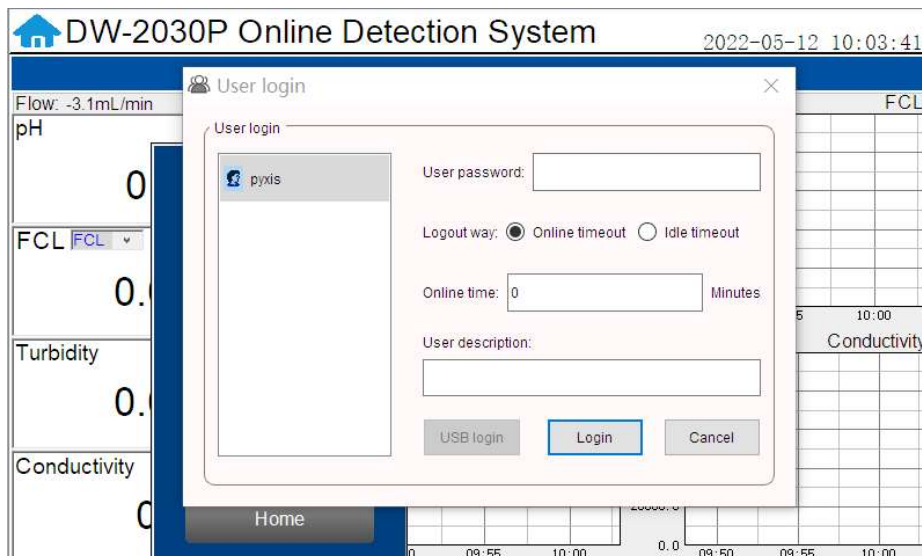
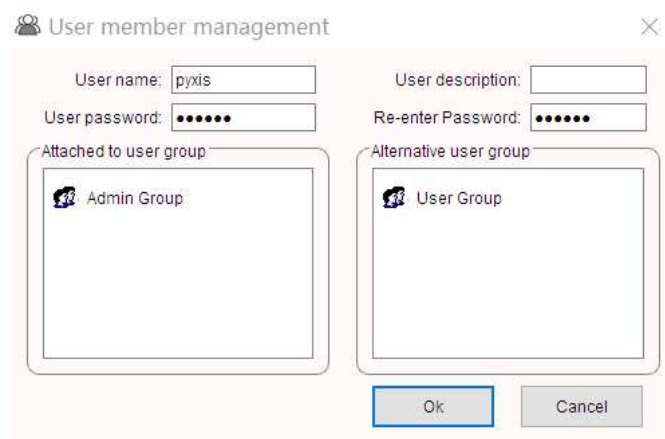

Figure 37 - User Management Screen

Modify Password: Select the user you want to change, then click Modify User button, enter the user's own password in the User Password column and Confirm Password column, and click Confirm to modify successfully. ***NOTE*** If you do not want to set the password, you can delete the password and save it.



The image shows a dialog box titled "User member management" with a close button (X) in the top right corner. The dialog contains several input fields and two list boxes. The "User name" field contains the text "pyxis". The "User password" and "Re-enter Password" fields are filled with six dots. The "Attached to user group" list box contains one item, "Admin Group". The "Alternative user group" list box contains one item, "User Group". At the bottom of the dialog are two buttons: "Ok" and "Cancel".

Figure. 38 Modifying the User Screen

7. Daily Maintenance

7.1. Correspondence Address

Number	Definition	Address	Format	Mode	Unit	Note
1	pH	1	float	Read Only	pH	Data format: ABCD
2	Turbidity	3	float	Read Only	NTU	Data format: ABCD
3	Chlorine	5	float	Read Only	mg/L	Data format: ABCD
4	pH Upper Limit Alarm	7	unit	Read Only		0=Normal / 1=Alarm
5	pH Lower Limit Alarm	8	unit	Read Only		0=Normal / 1=Alarm
6	Turbidity Upper Limit Alarm	9	unit	Read Only		0=Normal / 1=Alarm
7	Turbidity Lower Limit Alarm	10	unit	Read Only		0=Normal / 1=Alarm
8	Chlorine Upper Limit Alarm	11	unit	Read Only		0=Normal / 1=Alarm
9	Chlorine Lower Limit Alarm	12	unit	Read Only		0=Normal / 1=Alarm
10	Chlorine / pH Sensor Communication Abnormalities	13	unit	Read Only		0=Normal / 1=Alarm
11	Turbidity Sensor Comm Abnormalities	14	unit	Read Only		0=Normal / 1=Alarm
12	Temperature	15	float	Read Only	°C	Data format: ABCD
13	PLC Comm Error	17	unit	Read Only		0=Normal / 1=Alarm
14	Cleaning Module Comm Error	18	unit	Read Only		0=Normal / 1=Alarm
15	Brush Working Error	19	unit	Read Only		0=Normal / 1=Alarm
16	4-20mA Comm Error	20	unit	Read Only		0=Normal / 1=Alarm
17	TDS/Cond	21	float	Read Only	ppm-μS/cm	Data format: ABCD
18	TDS/Cond upper limit alarm	23	unit	Read Only		0=Normal / 1=Alarm
19	TDS/Cond lower limit alarm	24	unit	Read Only		0=Normal / 1=Alarm
20	TDS/Cond sensor communication is abnormal	25	unit	Read Only		0=Normal/ 1=Alarm
21	Panel Flow	26	float	Read Only	L / Min	Data format: ABCD
Communication Protocol: Standard Modbus-RTU						
Communication Parameters: Baud Rate - 9600, Data Bit - 8, Stop Bit - 1, Parity Bit - Even						
Station Number: 100						
Communication protocol: standard Modbus-TCP						
Communication parameters: IP: 192.168.0.3 (can be set); port: 502						
Station number: 1						

Table 2 - Correspondence Address

7.2. Operation and Maintenance

After the analyzer is installed by a qualified technician, it can begin to monitor water quality. The DW-2030P series inline detection system is designed to be simple to operate, but still requires some regular maintenance. Actual system maintenance may vary depending on the installation conditions and usage. Please refer to the table below as a general recommended maintenance schedule guideline. Little operator intervention is required during normal operation.

Required Services	Recommended Frequency
Cleaning DW-2030P Inlet Water Filter	Monthly or Cleaned As Needed
Cleaning of FT-100 Flow Tee and Photoelectric Pole	Monthly or Cleaned As Needed
pH Calibration	Every 6 Months
Turbidity Calibration	Every 6 Months
Chlorine Calibration	Every 6 Months
TDS/Conductivity Calibration	Every 6 Months

Table 3 - Maintenance Intervals

7.3. Instrument Alarms and Descriptions

Please refer to the instrument alarms and descriptions table when troubleshooting the DW-2030P inline inspection system issues an alarm or indicates abnormal measurement data.

Alarms	Description	Symptoms	Solutions/Recommendations
PLC Communication Abnormalities	PLC without Communication		Check if the wiring inside the PLC and control box is loose
Turbidity Sensor Communication Abnormality	Turbidity Sensor without Communication	No Turbidity Measurements	Check the connection between the sensor and the circuit board. If the problem persists, contact Pyxis.
pH / Chlorine Sensor Communication Abnormalities	pH / Chlorine Sensor without Communication	No pH and Chlorine Measurements	
pH Upper Limit Alarm	pH above the Alarm Setting	Information Only	Compare with manual measurement readings. Check and clean line valves. Check that water flow is normal. Check that the sensor is clean.
pH Lower Limit Alarm	pH below the Alarm Setting	Information Only	
Turbidity Upper Limit Alarm	Turbidity above the Alarm Setting	Information Only	
Turbidity Lower Limit Alarm	Turbidity below the Alarm Setting	Information Only	
Chlorine Upper Limit Alarm	Chlorine above the Alarm Setting	Information Only	
Chlorine Lower Limit Alarm	Chlorine below the Alarm Setting	Information Only	
Turbidity Calibration Failure Code 259	Low Calibration Standard Solution out of Range	Turbidity Calibration Failure	Check that the flow cell and sensor are clean, and that the standard solution is not contaminated
Turbidity Calibration Failure Code 260	Mid Calibration Standard Solution out of Range	Turbidity Calibration Failure	
Turbidity Calibration Failure Code 261	High Calibration Standard Solution out of Range	Turbidity Calibration Failure	
Turbidity Calibration Failure Code 262	Slope f1 out of Range	Turbidity Calibration Failure	
Turbidity Calibration Failure Code 263	Slope f2 out of Range	Turbidity Calibration Failure	
pH/Chlorine Calibration Failure Code 2		Calibration Failure	Check whether the water flow is normal, whether the sensor is clean, whether the standard liquid is contaminated
pH/Chlorine Calibration Failure Code 3	Standard Solution Value out of Range	Calibration Failure	
pH/Chlorine Calibration Failure Code 5	Wrong Data Type for the Liquid Value	Calibration Failure	

Table 4 - Common Alarms

7.4. Explanation and Use of the CHLORINE CHALLENGE Feature

The DW-2030P inline residual chlorine + pH sensor contains sophisticated averaging algorithms which allow for a ‘smoothing’ of the recorded chlorine residual. As the residual chlorine concentration in the water sample changes, this averaging software takes several minutes for the sensor reading to stabilize to the final concentration eliminating any potential “noise” which may be present. For applications where the DW-2030P is being utilized to verify the presence of a 0ppm chlorine residual, users may desire to conduct a system “challenge” with water containing chlorine to validate system performance and accuracy. The DW-2030P and other Pyxis panels have been equipped with the **CHLORINE CHALLENGE** for this specific purpose. By manually toggling the CHLORINE CHALLENGE button to **Challenge ON** the sensor data averaging feature is bypassed for a period of 600 seconds (10 Minutes), to speed up the sensor measurement frequency and the chlorine value stabilization more rapidly. This feature will automatically turn off at the 600 second mark and return to normal operation with the residual averaging firmware reactivated and will show a display of **Challenge OFF** . **NOTE* When in the "Challenge ON" state, calibration and range change operations cannot be performed.*

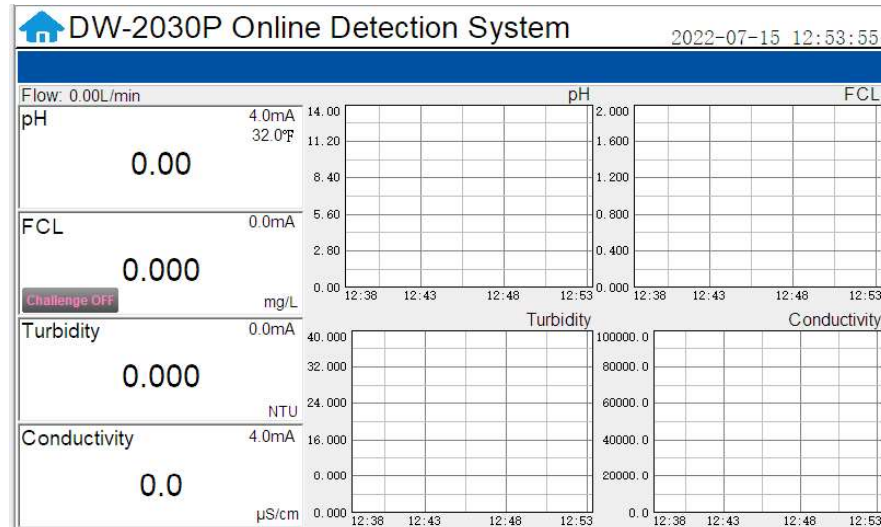
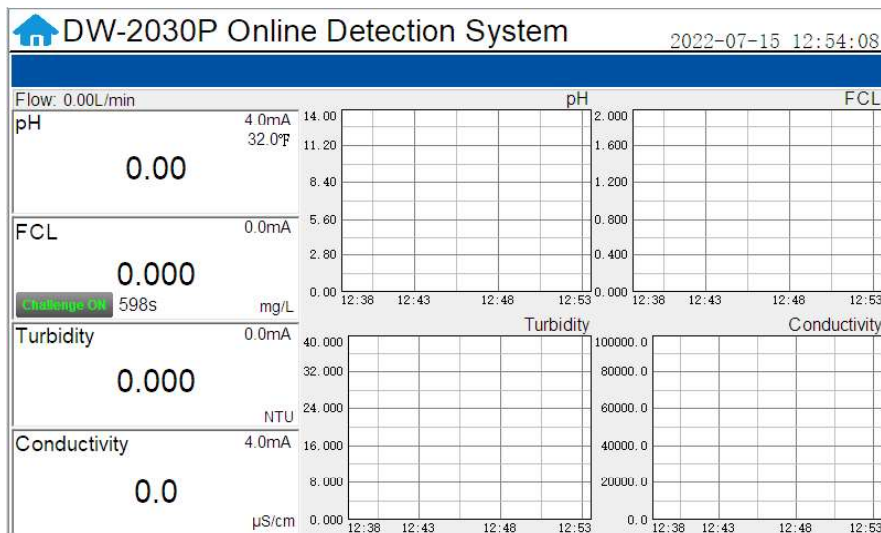

7.5. Explanation and Use of the HOLD Feature

The DW-2030P has an integrated HOLD feature for all Modbus TCP output parameters from the sensor that would be connected to an onsite DCS network. The purpose for this feature is to allow the user to enter a signal value HOLD on the designated parameter during periods of sensor maintenance or removal. This feature prevents network system alarms from operational shutdown during sensor maintenance or replacement.

Click the "**Hold OFF**" button on the main interface to enter the HOLD setting interface.

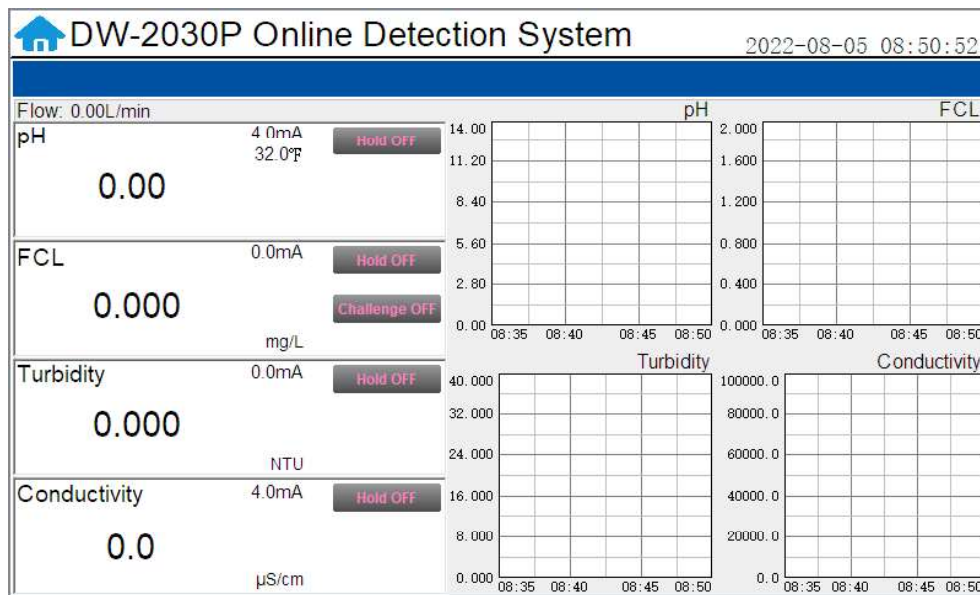

In the pop-up box, enter the parameter value and click "**Confirm**" to open the "**Hold ON**" function. The main interface will display the entered value for 15 minutes, after which it will resume displaying the real-time value read by the sensor.

When the "Hold ON" function is activated by the user, the sensor may be maintained, calibrated or removed and the Modbus TCP output will continue to retain the user entered value for a period of 15 minutes, ensuring network alarm and process will not be interrupted due to the sudden disappearance of the 'normal' value. The 'actual' live sensor reading along with the user entered hold value reading will both be displayed during this period.

Clicking "**Cancel**" will turn off this function, the main interface will immediately display the real-time value read by the sensor, and the main interface button will be displayed as "**Hold OFF**".

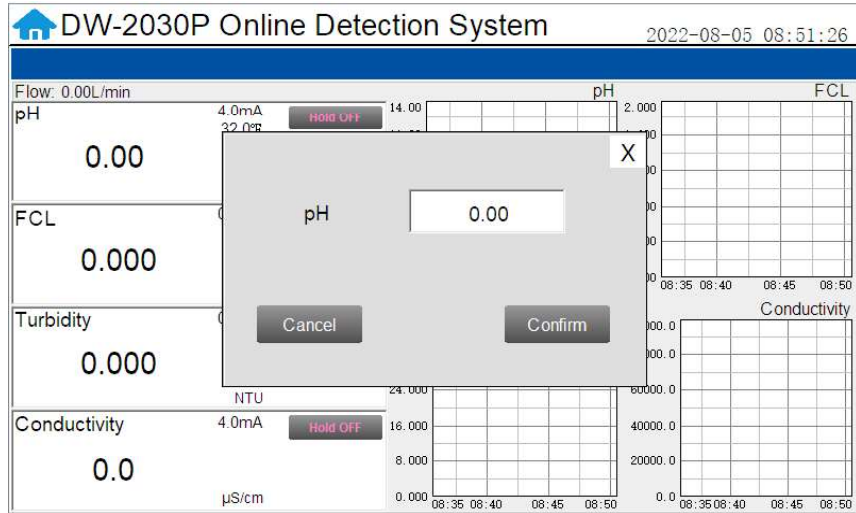

HOLD-ON Feature Screen - Entering the pH output value desired

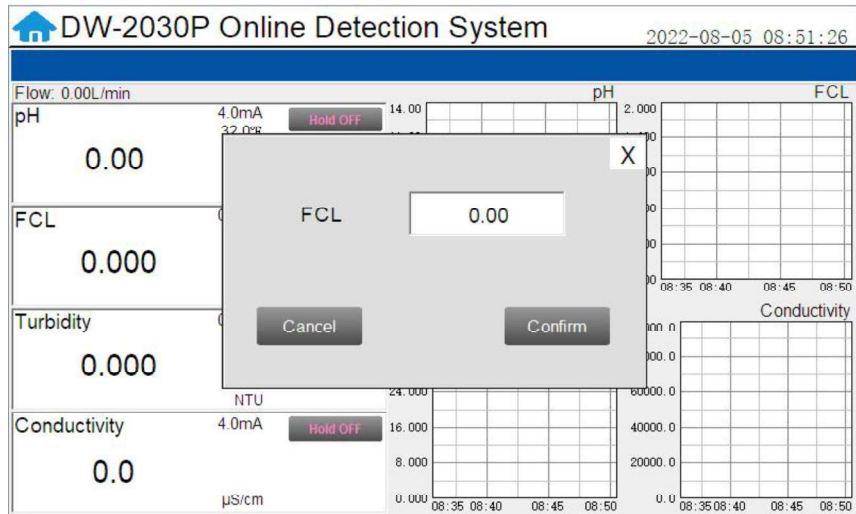

HOLD-ON Feature Screen - Entering the FCL/TCL output value desired

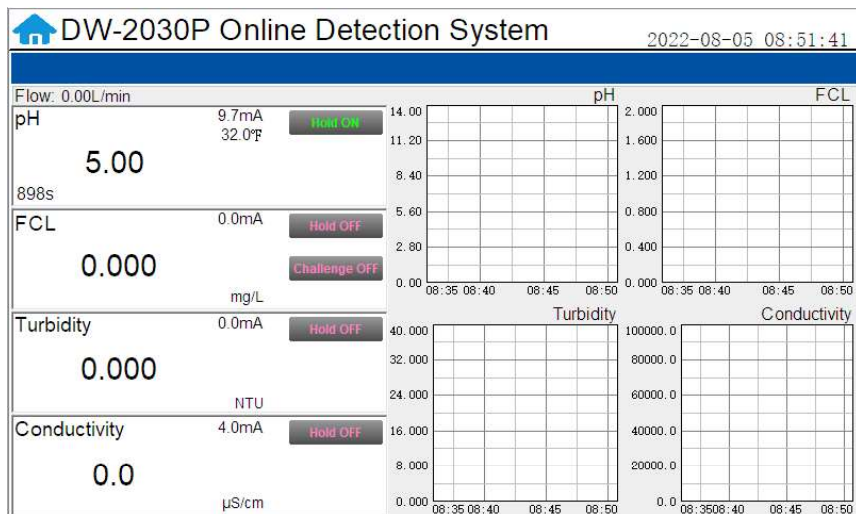

HOLD-ON Interface Screen

8. Replacing pH and Oxidizer/Sulfite Electrode Head

The pH/oxidizer electrode head of ST-765SS Series can be replaced when the original electrode head reaches its working life. Order a replacement electrode head EH-765 (P/N 53061) from Pyxis and follow instructions as below.

1. Turn off the sensor if it is powered on.
2. Make sure there is no water on the sensor.
3. Hold the ST-765SS main body with one hand and use the other hand to twist the stainless-steel locking ring counter-clockwise until the front end of the black electrode is completely unscrewed, as shown in *Figure 38-2*.
4. Pull out the electrode head as shown in *Figure 38-3*.
5. Loosen the electrode plug connector, and remove the electrode head, as show in *Figure 38-4*.
6. To assemble the new electrode head, connect the plug, then insert the new electrode head into the main sensor housing and ensure that the two protrusions on the electrode head are aligned with the notches in the sensor main housing.
7. Then twist the stainless-steel lock ring of ST-765SS in a clockwise direction until the threads of the electrode head completely enter the ST-765SS housing as shown in *Figure 38-1*.

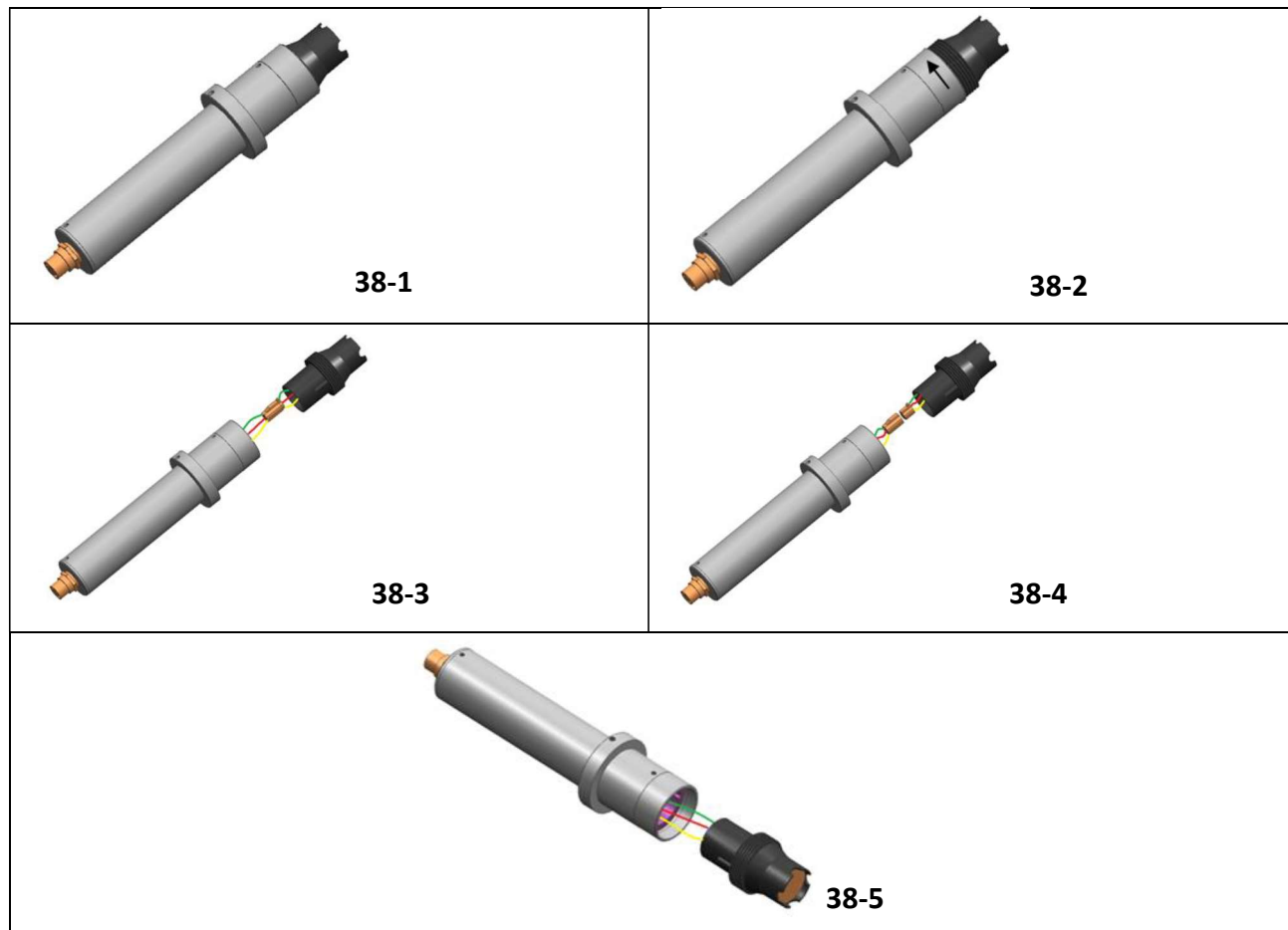

Figure 38 - Replacing EH-765 pH and Oxidizer Electrode Head

9. UC-80 & UC-100 Series

Setting the Date and Time - Firmware Update Procedure

9.1. Setting the Date and Time

- 1) When the device is powered on again, when the following screen appears on the screen, tap the screen immediately

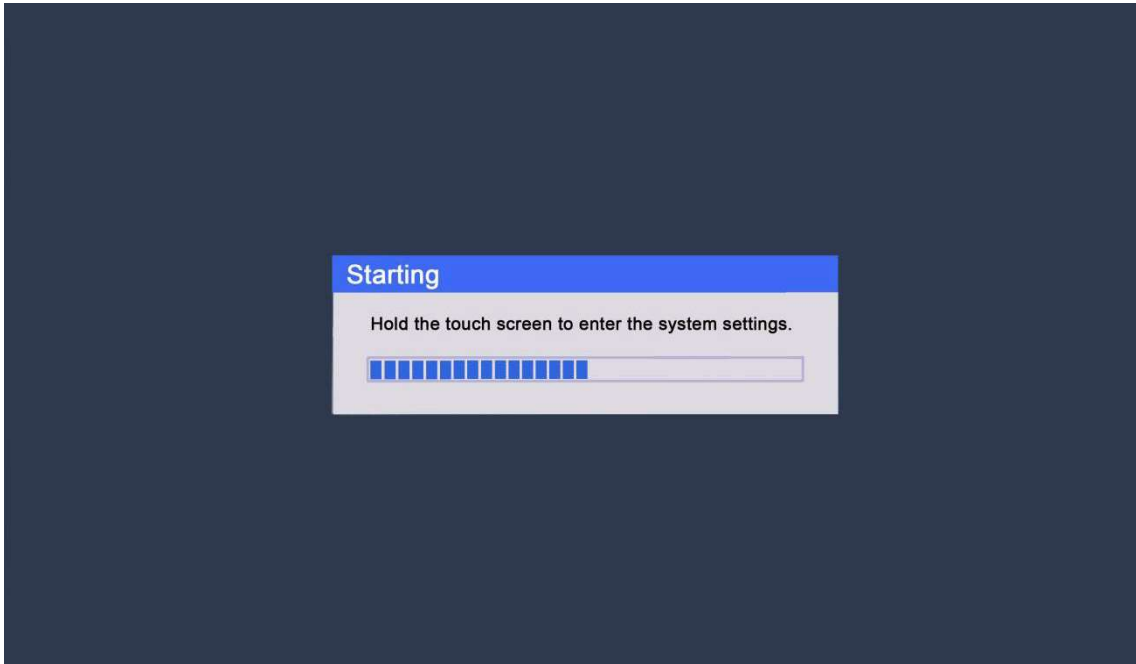

- 2) Enter the system interface, as shown in the figure below, click the button "System setting"

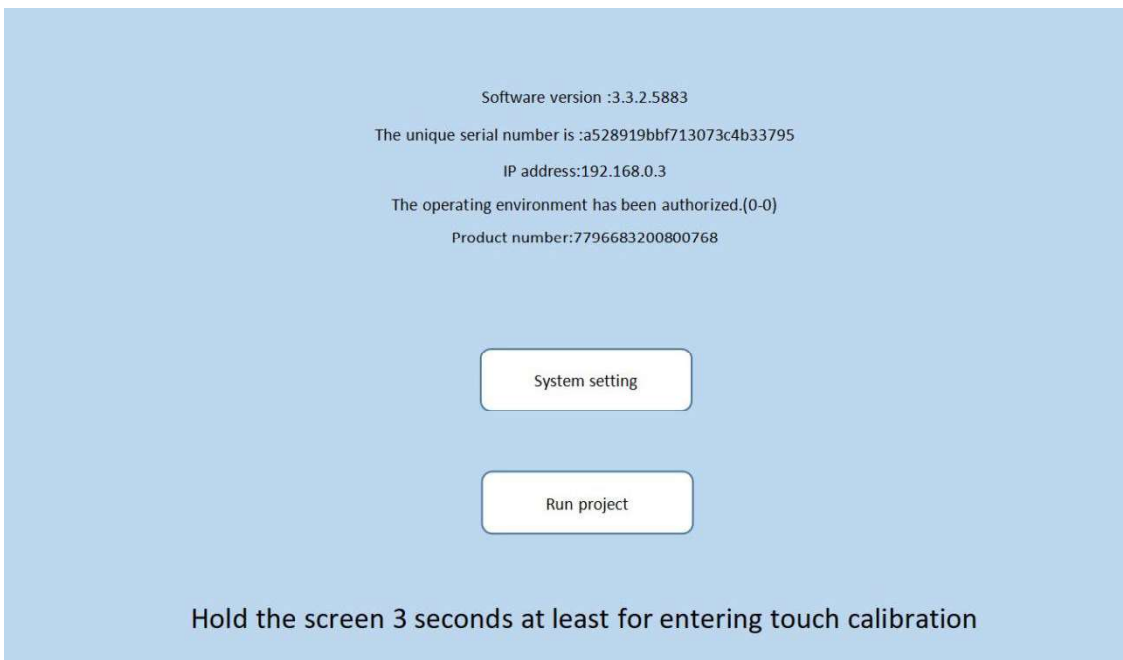

- 3) Enter the setting interface, select the time parameters, as shown in the figure below, and modify the time. After the modification is completed, click the "OK" button to confirm. After closing the setting interface, click "Run project" to enter the program running interface.

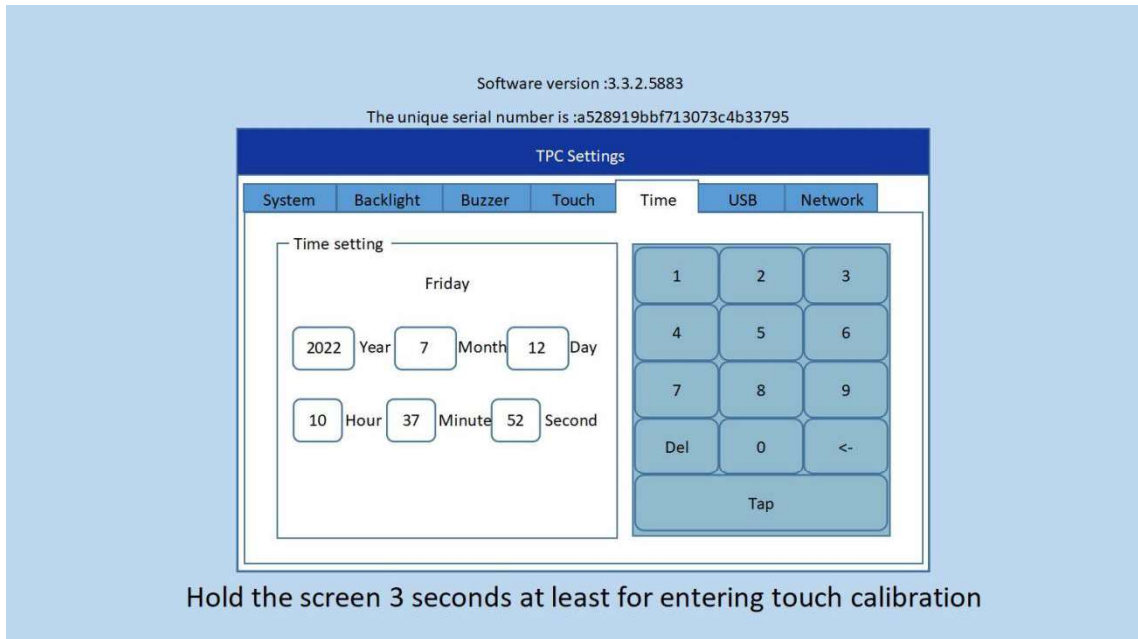

9.2. Firmware Update Procedure

- 1) Decompress the program update package, copy the "**tpcbackup**" file and save it to a USB flash drive in "FAT32" format. ***NOTE*** *You need to copy the entire folder to the root directory of the USB flash drive.*
- 2) Insert the USB flash drive into the USB1 port on the rear of the touch screen.
- 3) After inserting the USB flash drive, the touch screen will pop up. Click "**YES**" and wait for the screen to jump, as shown below.

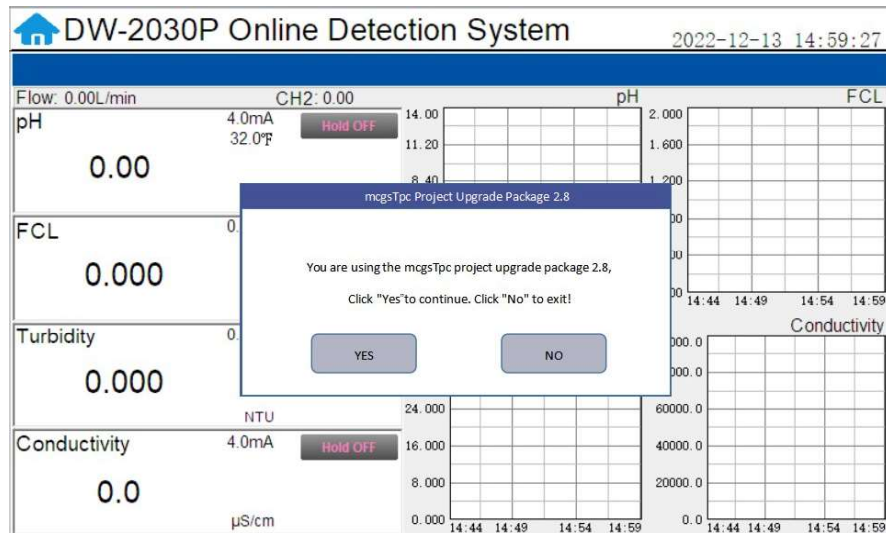

- 4) In the new pop-up box, click "**Download Project**", as shown below.

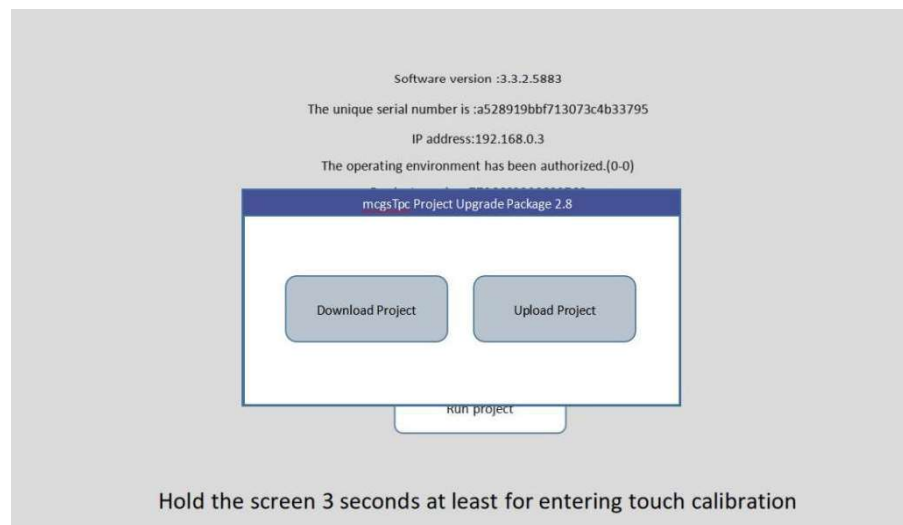

5) In the new pop-up box, select the program name on the left and click "Download". The touch screen will start to download the program. See figure below



6) When the rewind is over, the touch screen will restart, and the screen will turn black during the restart. At this time, you can pull out the USB disk, as shown in Figure 4

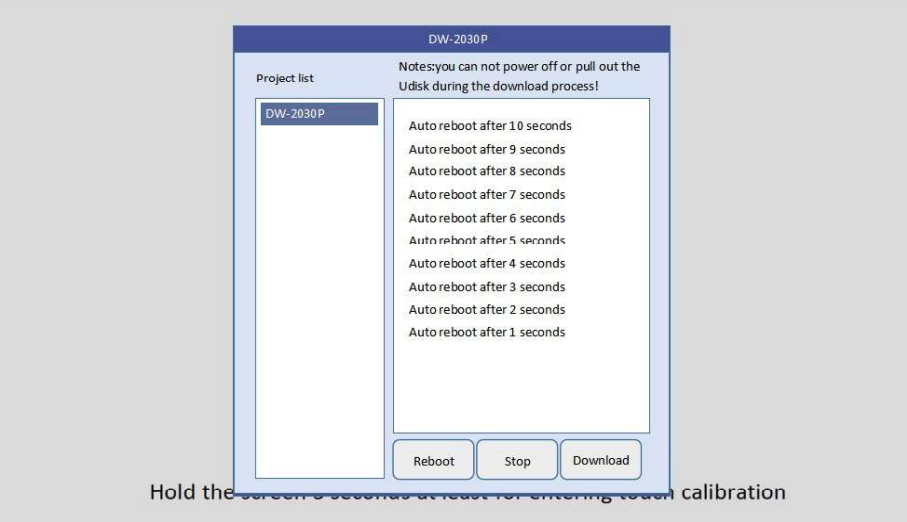

- 7) If the update screen appears again after restart, please click "NO" and pull out the USB disk, as shown in Figure 5

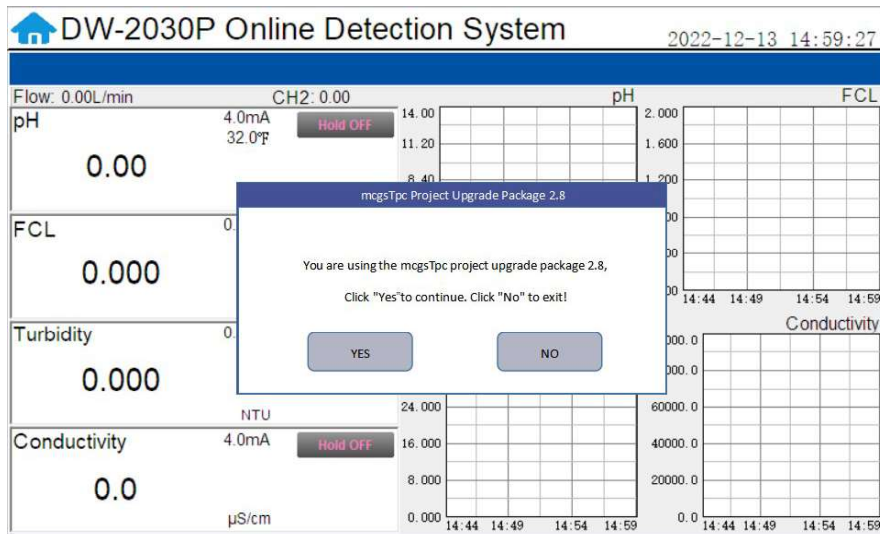

10. Order Information

Order Information

DW-2030P-US <i>(Beverage/Drinking Water Analyzer)</i>	P/N 42164
DW-2030P-US-G <i>(Beverage/Drinking Water Analyzer with CloudLink 4G Gateway)</i>	42168

Optional / Replacement Accessories Information

	P/N
LT-739 Ultra-Low Turbidity <i>(Warm White LED 0.000 - 40.00 NTU)</i>	53221
ST-765SS-FCL <i>(Free/Total Chlorine + pH + Temperature Sensor w/Internal Compensation-Sensor Only)</i>	53607-NFR
ST-720 <i>(Conductivity 4-Graphite Electrode 1 – 100,000 µS/cm)</i>	53101
EH-765 <i>(Replacement Electrode Head for ST-765SS-FCL)</i>	53061
Air Vent Valve Assembly <i>(Replacement Air Vent Valve Assembly)</i>	50700-A54
Hall Effect Flow Meter <i>(Replacement Pulse Flow Meter ¼-inch 0.25-2.5L/Min)</i>	16008
ST-001 <i>(Replacement Inline Tee Assembly for ST-765 / ST-720 Sensors)</i>	50704
FT-100 <i>(Replacement Inline Tee Assembly for LT-739 Sensor)</i>	50780
FT-100-PLUS <i>(Self-Brushing Inline Tee Assembly for LT-739)</i>	16005
UC-100A <i>(Replacement Display & Data Logging Terminal)</i>	43054
L-CAL <i>(Portable Liquid Formazin Calibration Kit for LT-73X Series Sensors)</i>	53247
Pyxis Turbidity Calibration Std – 5.0 NTU <i>(4,000mL)</i>	57010-5L
Pyxis Turbidity Calibration Std – 10.0 NTU <i>(4,000mL)</i>	57010-10L
Pyxis Turbidity Calibration Std – 20.0 NTU <i>(4,000mL)</i>	57010-20L
Pyxis pH Combo Calibration Pack <i>(pH 4-7-10 Calibration Solution 3-Pack - 500mL ea.)</i>	57007
Pyxis Conductivity Calibration Std – 1,000 µS/cm <i>(500mL)</i>	57008
SP-200 OxiPocket™ <i>(Pocket All-Oxidizing Disinfectants Colorimeter & Fluorometer)</i>	50802

Contact Pyxis Lab

info@pyxis-lab.com for general inquiries

service@pyxis-lab.com for technical service and support

order@pyxis-lab.com for order and pricing inquiries

1-866-203-8397 Phone USA for all needs

Office Hours 7AM --5PM Central Time USA