

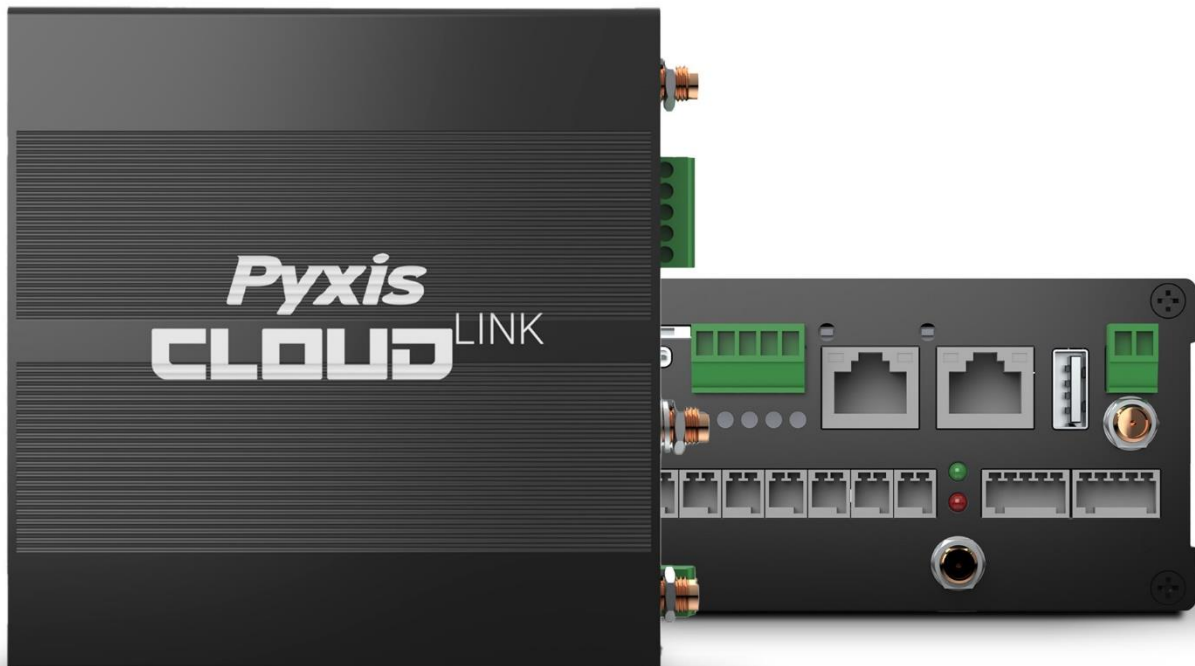

CloudLink™ TC-220 4G LTE Gateway

4G LTE Remote Communication & Monitoring Device for Industrial Equipment



Pyxis Lab® Inc.

21242 Spell Circle
Tomball, TX 77375
www.pyxis-lab.com

USER MANUAL

The information contained in this manual may be confidential and proprietary and is the property of Pyxis Lab, Inc. Information disclosed herein shall not be used to manufacture, construct, or otherwise reproduce the goods described. Information disclosed herein shall not be disclosed to others or made public in any manner without the express written consent of Pyxis Lab, Inc.

Limited Warranty

Pyxis Lab warrants its products for defects in materials and workmanship. Pyxis Lab will, at its option, repair or replace instrument components that prove to be defective with new or remanufactured components (i.e., equivalent to new). The warranty set forth is exclusive and no other warranty, whether written or oral, is expressed or implied.

Warranty Service

Damaged or dysfunctional instruments may be returned to Pyxis for repair or replacement. In some instances, replacement instruments may be available for short duration loan or lease.

Pyxis warrants that any labor services provided shall conform to the reasonable standards of technical competency and performance effective at the time of delivery. All service interventions are to be reviewed and authorized as correct and complete at the completion of the service by a customer representative or designate. Pyxis warrants these services for 30 days after the authorization and will correct any qualifying deficiency in labor provided that the labor service deficiency is exactly related to the originating event. No other remedy, other than the provision of labor services, may be applicable.

Repair components (parts and materials), but not consumables, provided in the course of a repair, or purchased individually, are warranted for 90 days ex-works for materials and workmanship. In no event will the incorporation of a warranted repair component into an instrument extend the whole instrument's warranty beyond its original term.

Warranty Shipping

A Repair Authorization Number (RA) must be obtained from Pyxis Technical Support before any product can be returned to the factory. Pyxis will pay freight charges to ship replacement or repaired products back to the customer. The customer shall pay freight charges for returning products to Pyxis. Any product returned to the factory without an RA number will be returned to the customer.

Pyxis Technical Support

Contact Pyxis Technical Support at service@pyxis-lab.com or 1-866-203-8397 (Mo-Fri 7:00AM-5PM MT)

Table of Contents

1	Introduction	5
1.1	Features	5
1.2	Specifications	6
1.3	Unpacking the CloudLink™	6
1.4	Standard Accessories	6
2	Using the Pyxis CloudLink™ TC-220	7
2.1	Layout & Description of Front and Rear Panel	7
2.2	Installing the 4G Antenna	8
2.3	Configuring CloudLink	8
2.3.1	Connecting to CloudLink	8
2.3.2	CloudLink Dashboard Page	9
2.3.3	Connect to Probes.....	10
	2.3.3.1 Manually Select Probes.....	11
	2.3.3.2 Auto Discover Probes.....	11
	2.3.3.3 Utilities for Modbus Probes.....	12
2.3.4	Connect to Controllers.....	12
	2.3.4.1 CloudLink Setup as Modbus TCP Client.....	13
	2.3.4.2 CloudLink Setup as Modbus TCP Server.....	15
2.3.5	Connect to a LoRa Device	16
2.3.6	Configure Network.....	17
	2.3.6.1 Configure Wired Network.....	17
	2.3.6.2 Configure Wireless Network.....	18
	2.3.6.3 Configure Cloud Interface.....	19
	2.3.6.4 Configure Port Forwarding	20
	2.3.6.5 Configure Firewall	21
2.3.7	System Configuration & Control	23
	2.3.7.1 Configure General Settings	23
	2.3.7.2 Configure LoRa Communication Settings.....	24
	2.3.7.3 Configure Modbus RTU Communication Settings.....	24
	2.3.7.4 Software Upgrade	25
	2.3.7.5 Import/Export Configurations	25
3	Pyxis Gateway Service	26
3.1	Activate Remote Connection	26

4	Application Example	28
4.1	General Gateway	28
4.2	Gateway for Pyxis Sensors via RS485.....	28
4.3	Gateway for Pyxis Sensors via LoRa	29
5	Dimension (inch/mm).....	30
6	Appendix.....	31
6.1	CloudLink Modbus Register Definition	31
6.1.1	System Info.....	31
6.1.2	Cellular Info	31
6.1.3	Probe Readings	31
6.1.4	LoRa Readings	32
6.1.5	Controller Readings.....	32
7	REGULATORY APPROVAL	35

1 Introduction

Pyxis CloudLink™ TC-220 is an IoT device designed for remote communication and monitoring of industrial equipment. The device supports a 4G-LTE cellular network as well as wired and wireless networks. In addition, Pyxis CloudLink™ also supports long range wireless communication (i.e., LoRa) to enable data collection from remote areas where cellular signal is not available. Pyxis CloudLink™ has a built-in RS-485 interface that makes it capable of communicating with all Pyxis sensors as well as third-party sensors via Modbus RTU protocol.



Pyxis CloudLink™ is ideally suited for industrial IoT applications such as remote data collection, reporting and alarming. The device is designed to work with the Pyxis Cloud platform and other third-party Cloud platforms seamlessly (requires additional software upgrading). Data collected by the Pyxis CloudLink™ can be configured to send to your preferred Cloud platform in a secure way, with just a few clicks you will get your remote data visualized on desktop PC or mobile devices.

1.1 Features

- High performance hardware platform
- Features ARM cortex-A7 CPU up to 900MHz and up to 256MB memory
- LTE Cat 4 module optimized for IoT applications; major carriers supported world wide
- Versatile interfaces to support from legacy system to modern DCS/PLC
- Intuitive web interface for system configuration and control
- Modbus RTU interface to integrate with Pyxis digital sensors
- Modbus TCP interface to interact with various controllers and DCS
- Port forwarding function to provide flexible access to the equipment in the internal network
- Firewall module allows user to setup inbound/outbound rules to protect your critical assets
- Rugged design to work in harsh environment

1.2 Specifications

Specifications are subject to change without notice. Contact Pyxis (service@pyxis-lab.com) for an updated specification list.

Item	CloudLink™ TC-220
Part Number	43030
CPU	ARM Cortex-A7 32-bit Processor, up to 900MHz
RAM	256MB
Storage	256MB
Ethernet port	x 2 RJ-45 (10/100M Base-T)
Serial port	x 1 RS-485 with 24V output
Sim slot	x 1
Micro SD slot	x 1
USB port	x 1
On board RTC:	YES
LTE category	4
Bands supported	B1/2/3/4/5/7/12/13/14/20/28/66/71
Carriers Supported (US)	AT&T, Verizon, T-Mobile
Protocols Supported	IP/TCP/UDP/HTTP/HTTPS/Modbus RTU/Modbus
Operation Temperature	-4 to 122°F (-20 - 50°C)
Storage Temperature	-13 to 140°F (-25 - 60°C)
Humidity	0 - 95%, non-condensing
Power Supply	6-35 VDC, Max. 4W power consumption
Regulation	CE, RoHS, UKCA
Dimension (L x W x H)	105 x 104 x 40 (mm)
Weight	330 g

1.3 Unpacking the CloudLink™

Remove the instrument and accessories from the shipping package and inspect each item for any damage that may have occurred during shipment. Verify that all items listed on the packing slip are included. If any items are missing or damaged, please contact Pyxis Customer Service at service@pyxis-lab.com.

1.4 Standard Accessories

The following accessory is included in the package:

- 4G Antenna x 1
- Wi-Fi Antenna x 1
- LoRa Antenna x 1
- CAT-6 Ethernet Cable x 1
- Mounting brackets
- Din Rail installation components

2 Using the Pyxis CloudLink™ TC-220

2.1 Layout & Description of Front and Rear Panel

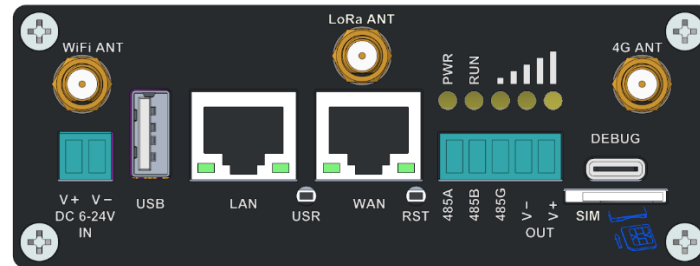

Figure 1. Connectors on the Front Panel

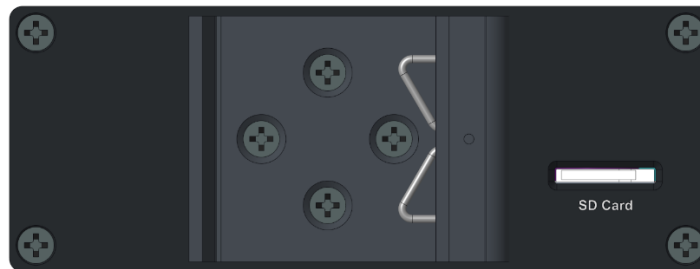



Figure 2. SD Card Slot on the Rear Panel

Here is the description of each connector on the front panel:

- **Wi-Fi ANT:** SMA connector for Wi-Fi antenna
- **V+ V-/DC 6-24V:** Power input connector, recommend using 24VDC power supply. V+ is the positive terminal of power input.
- **V+ V- OUT:** Power supply for external devices. The voltage level is the same as the power input. (e.g., if external power input is 9V, CloudLink only outputs 9V).
- **LAN (WAN):** 10/100M Ethernet Port, auto negotiation speed
- **LED Indicators:**
 - **PWR:** Lit when Power On
 - **RUN:** System running status (blink every second)
 - : Indicator of 4G signal strength
- **485A/485B/485G:** RS485 communication wires, where 485G is GROUND signal for RS485 Port
- **DEBUG:** For debugging purpose
- **RST:** Push to reset CloudLink
- **3G/4G ANT:** SMA connector for 3G/4G antenna
- **LoRa ANT:** SMA connector for the Long-Range Radio antenna
- **SIM:** Micro-SIM card slot

2.2 Installing the 4G Antenna

When installing CloudLink in the field, please find an appropriate place where the 4G signal is as strong as possible to install the antenna. The antenna has a magnetic base and can be easily attached to metal objects, or you can use double-sided tape to attach the antenna to where cellular signal has good reception.

2.3 Configuring CloudLink

2.3.1 Connecting to CloudLink

Connecting via CloudLink WAN Interface

The CloudLink device supports configuration via Ethernet interface or Wireless interface. The default Ethernet IP address of CloudLink WAN interface is **192.168.10.110**, connect the CloudLink WAN port to your computer with an Ethernet cable, and set your computer IP address to 192.168.10.XXX (where XXX can be any number between 1 to 250, except 110) according to Figure 3. ***NOTE*** Please leave Default gateway blank.

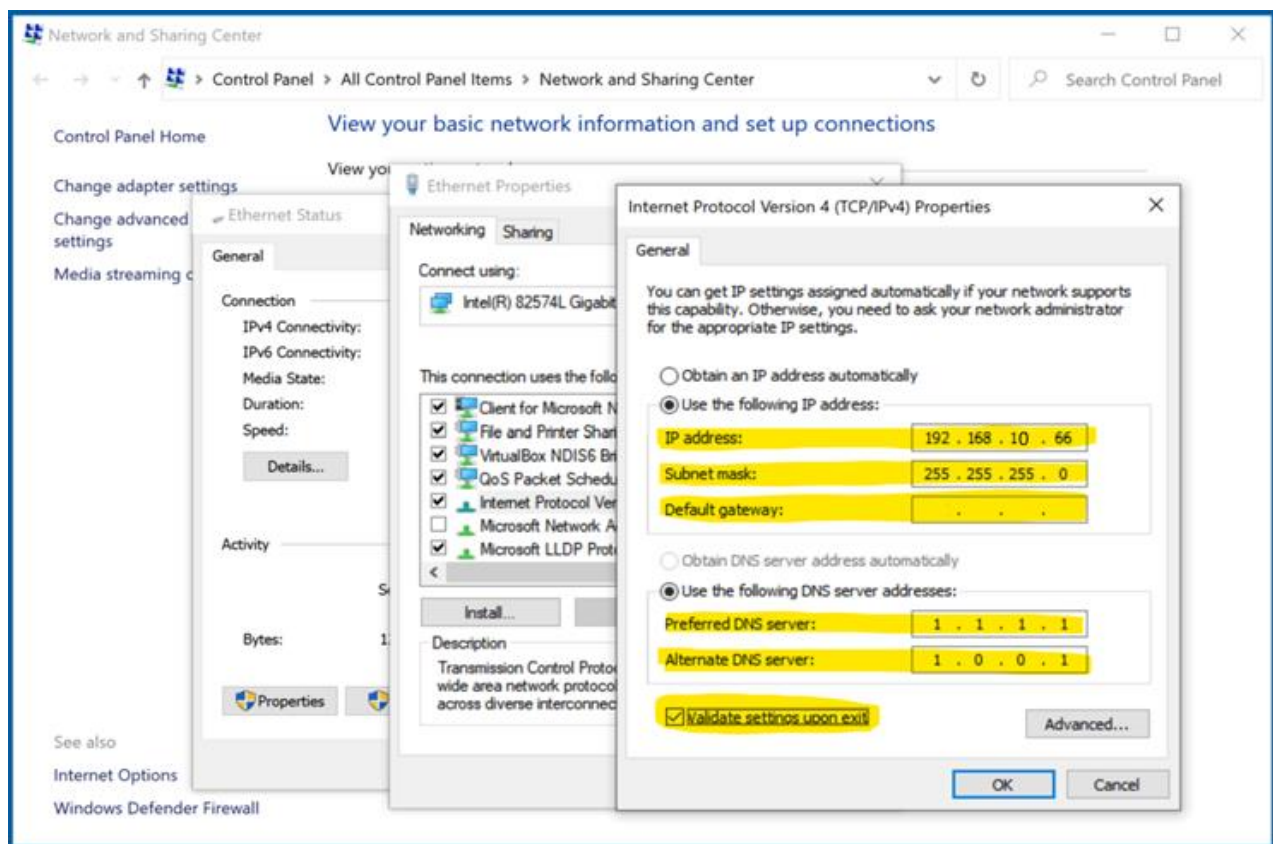

Figure 3 - Set Static IP

Connecting via CloudLink LAN Interface

The default Ethernet IP address of CloudLink LAN interface is **192.168.0.1**, connect the CloudLink LAN port to your computer with an Ethernet cable, setup your computer to obtain IP address via DHCP or manually set your computer IP address to 192.168.0.XXX (where XXX can be any number between 2 to 250, except 1). ***NOTE*** Please leave Default gateway blank.

Connecting via CloudLink Wi-Fi Interface

CloudLink is setup as Wireless AP by default. The default Wi-Fi SSID is **CloudLinkPro** and default Wi-Fi password is **wifi1234**. Search CloudLink Wi-Fi hotspot and connect to it, you can use PC, laptop or mobile device to connect to CloudLink Wi-Fi.

2.3.2 CloudLink Dashboard Page

For this section, assume we are connecting to CloudLink device via its WAN interface. Open the CloudLink web page <http://192.168.10.110>. The CloudLink login page will load as shown in Figure 4.

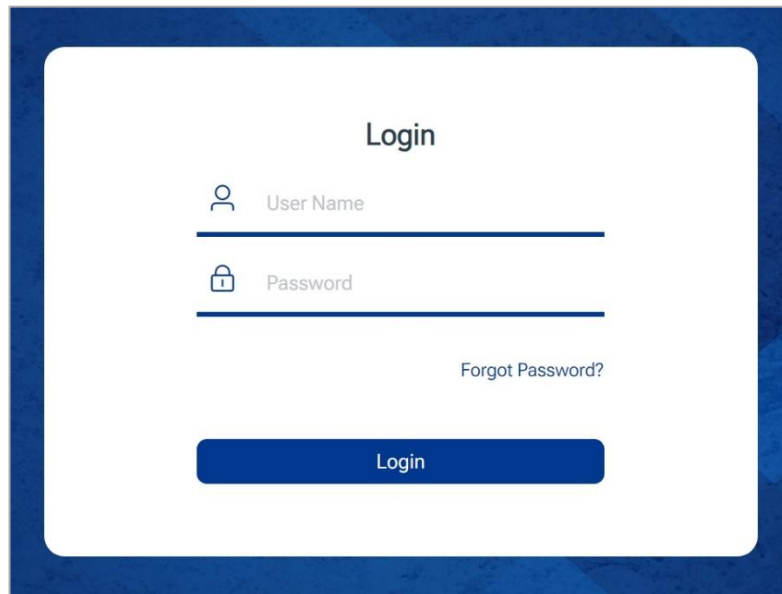

Figure 4 - Login Screen

The default username is **admin** and default password is **pwd123**. Click the Login button to proceed with user authentication.

The CloudLink dashboard page will be loaded once username and password authentication successfully as shown in Figure 5. The dashboard page consists of four section blocks. The **LTE Connection** section displays information of the 4G-LTE module and cellular network status such as network carrier name, cellular signal strength and IP address; The **Probe Status** section will show real-time readings of each probe connected to the CloudLink device via RS-485 interface; The **System Info** section provides CloudLink model, serial number, operation hours and usage statistics such as CPU, RAM and storage; The **LoRa Status** section gives insights into the LoRa network parameters such like frequency and bandwidth, as well as LoRa devices that are connected to CloudLink.

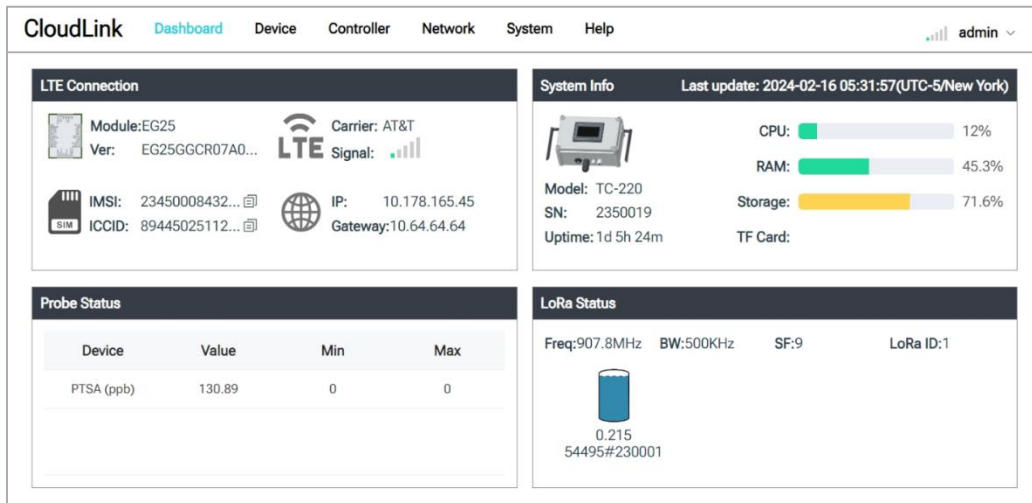

Figure 5 - CloudLink Dashboard

2.3.3 Connect to Probes

The CloudLink is capable of concurrently collecting data from up to 20 digital (Modbus RTU) probes. Upon selecting **Device** from the Navigation bar and clicking on **Probe** in the Sidebar, you will be presented with Figure 6.

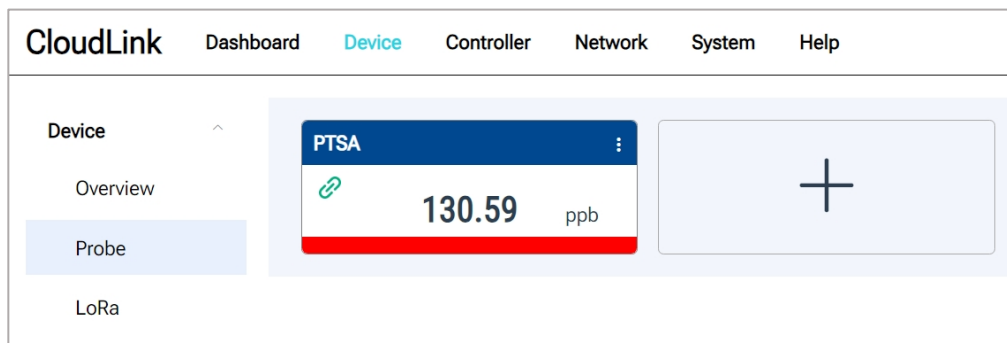

Figure 6 - Probe Dashboard

To add probes to the CloudLink, simply click the plus sign, in the pop-up window, you can further choose **Manual Select** or **Auto Discover** as shown in Figure 7.

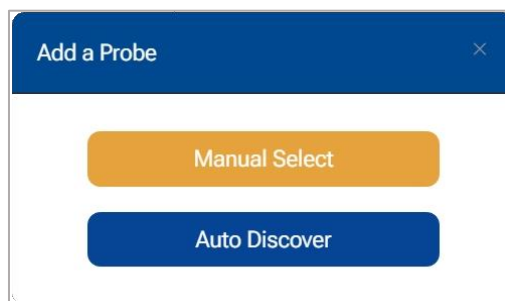

Figure 7 - Select How to Add Probe

2.3.3.1 Manually Select Probes

If you choose **Manual Select**, please further specify the Probe Type by selecting the desired probe from the dropdown list. Over 20 different Pyxis Lab probes are currently supported, and more Pyxis Lab probes will be integrated in future releases. The Modbus address will be automatically determined once the probe type has been selected, please leave the Modbus address as it is unless you know the exact Modbus address of the probe. The Measure Type are the measurements of the probe, they are determined by probe type and are auto-populated once the Pyxis probe type has been selected. You can change the customized name, unit and data precision of each measure type. Click the **Save** button to add the probe to CloudLink after all parameters have been configured properly.

IMPORTANT NOTE If more than one of the same types of Pyxis probe is to be connected to CloudLink, please make sure they are setup with different Modbus address before you connect them to RS485 bus. To do this you may connect one probe at a time and use CloudLink probe utility **->Set Address** to change its Modbus address, as shown in Figure 10.

Measure Type	Customized Name	Unit	Precision	Enable
PTSA	ST-588 PTSA	ppb	2 decimal	<input checked="" type="checkbox"/>
TAG	ST-588 TAG	ppm	2 decimal	<input checked="" type="checkbox"/>
Cleanliness	ST-588 Cleanliness	%	0 decimal	<input checked="" type="checkbox"/>

Figure 8 - Add Probe Manually

2.3.3.2 Auto Discover Probes

If you choose **Auto Discover**, CloudLink will begin scanning the RS485 bus to identify any Pyxis probes, the identified probes will be listed on the Auto Discover Probes page. It typically takes 2-3 minutes to complete scanning the RS485 bus, but you can always stop the scanning process halfway through if all probes have been recognized. Click the **Add** button to add all scanned probes to CloudLink.

Probe	Modbus Address	Serial Number	Enable
Empty Data			

Figure 9 - Add Probe Automatically

2.3.3.3 Utilities for Modbus Probes

CloudLink provides various utilities to interact with a probe. These utilities help with checking the connectivity to a probe, calibrating a probe, reading diagnosis data from a probe and updating probe's Modbus address. Click the three dots on the upper-right corner of each probe display block to show the sub-menu for the utilities.

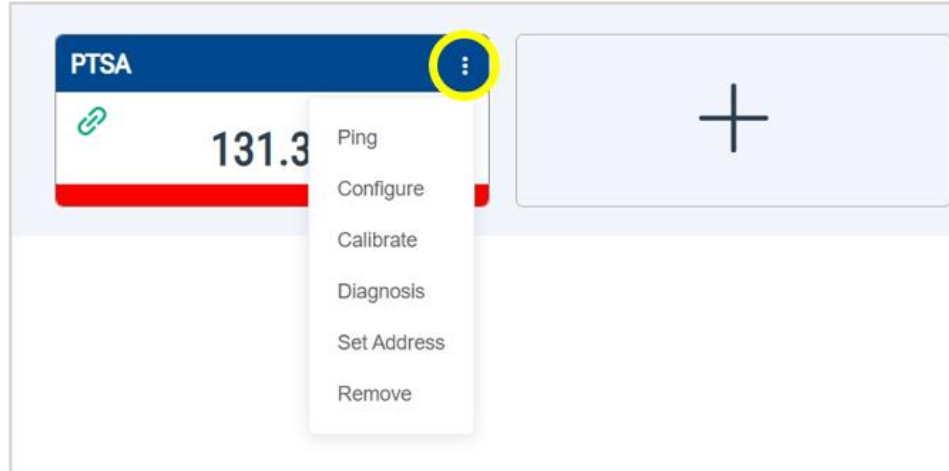

Figure 10 - Probe Utilities

2.3.4 Connect to Controllers

CloudLink uses Modbus TCP to connect to external controllers. CloudLink can be set up as either a Modbus TCP server or a Modbus TCP client. If CloudLink is set up as a Modbus TCP server, the controller will read values from or write values to CloudLink; if CloudLink is set up as a Modbus TCP client, it will read values from and write values to the controller.



Figure 11 - Connect to Controller

2.3.4.1 CloudLink Setup as Modbus TCP Client

As shown in Figure 11, connect CloudLink's LAN or WAN port to the controller via Ethernet cable and set up the controller IP address accordingly (see Section 2.3.1). Follow the web interface to add the controller to CloudLink. Select **Controller** from the Navigation bar and click  and you will be presented with Figure 12.

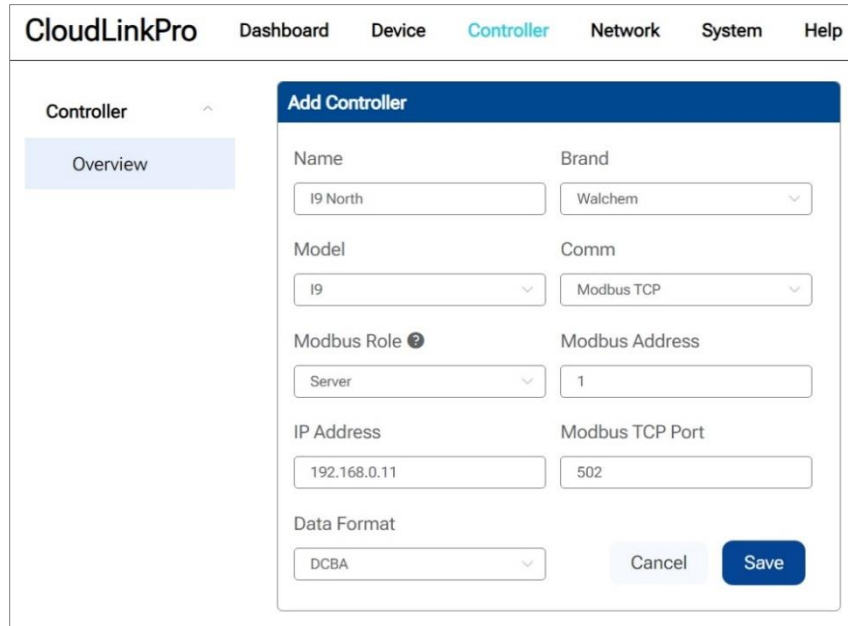

Figure 12 - Add Controller

Please note, the **Modbus Role** settings tab in the controller setup page is to define the Modbus TCP role of a controller. If a controller is setup to server role, then CloudLink will be automatically configured as client role. Please refer to the controller user's manual for the rest of the settings such as **Modbus Address**, **Modbus TCP Port** and **Data Format**. Please manually configure controller's IP address if controller is connected to CloudLink's WAN interface, e.g., 192.168.10.3; if controller is connected to CloudLink's LAN interface, it's IP address can be obtained via DHCP or configured manually. In either case, please check its IP address in controller HMI and fill in here.

Please further set up the controller Modbus registers if a controller is configured to server role. Click the three dots at the upper-right corner of the controller display block to show the register setup menu as shown by Figure 13.

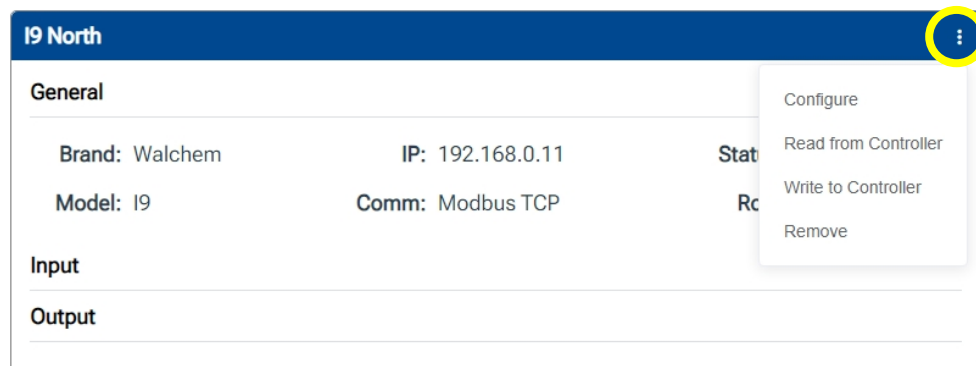

Figure 13 - Controller Register Setup

Click [Read from Controller](#) to start configuring registers as shown by Figure 14, please consult to controller user’s manual to obtain register attributes such as name, address, data type, unit, etc., you can add registers in this page one by one or you can upload a CSV file where all registers’ information are kept to speed up the process.

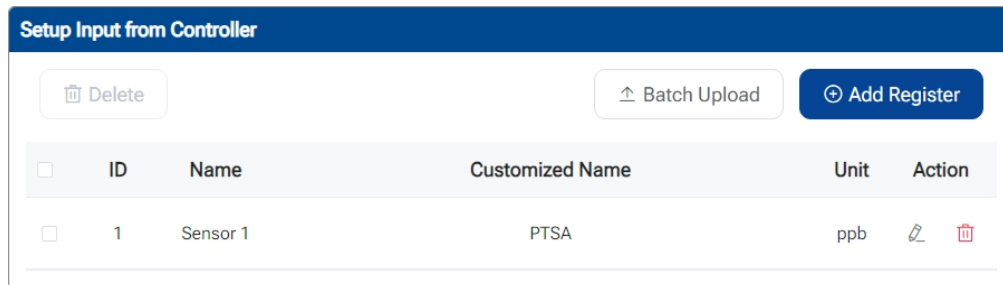

Figure 14 - Add Input Registers

When choosing [Batch Upload](#), please prepare a CSV file with all register information. Below is an example of such a file, where the first line of this file is the designation of each field, the rest of the lines are register attributes with each line representing one register.

```
Name (string16),Customer name (string16),Address,Length,Type,Unit (string16),Precision
pH, pH, 0, 2, FLOAT, , 2
Turbidity, Turbidity, 2, 2, FLOAT, NTU, 3
FCL, FCL, 4, 2, FLOAT, mg/L, 3
Temp, Temp, 14, 2, FLOAT, °F, 1
```

Click [Write to Controller](#) to start to configure output registers as shown by Figure 15, further click [Add Register](#) button to add registers one by one as shown by Figure 16.

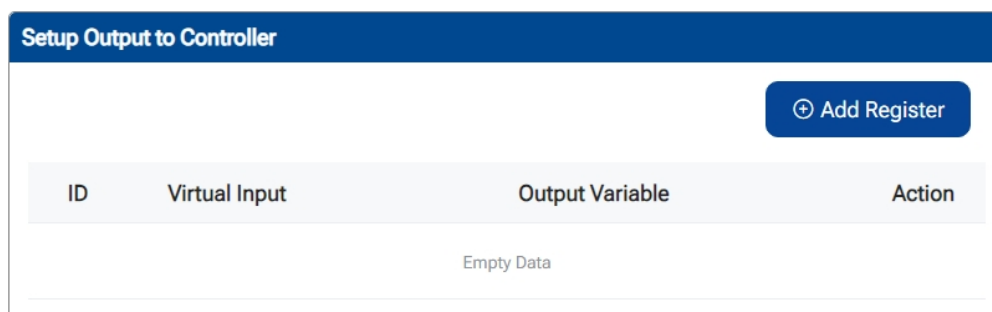

Figure 15 - Add Output Registers

Please note, the output register address is pre-determined by CloudLink once the controller brand and model are selected. The output variable can be selected from a drop-down list where you can choose probe readings, analog input signals (only available on TC-221), or LoRa device values.

Add Output Register

* Virtual Input

* Output Variable

Figure 16 - Choose Output Variables

2.3.4.2 CloudLink Setup as Modbus TCP Server

If CloudLink is set up as a Modbus TCP server, the external controller will read values from CloudLink or write settings to CloudLink via Modbus TCP protocol. Please refer to the appendix for CloudLink register map and communication settings.

2.3.5 Connect to a LoRa Device

CloudLink can communicate with remote devices via Long Range Radio (aka LoRa). Please set up the LoRa communication settings on the [System](#) page as shown in Figure 17. All LoRa devices must be set to the same frequency, bandwidth, spreading factor, and code rate in order to communicate with each other.

NOTE In general, if the distance between the LoRa device and CloudLink increases, please set the Spreading Factor to a larger value.

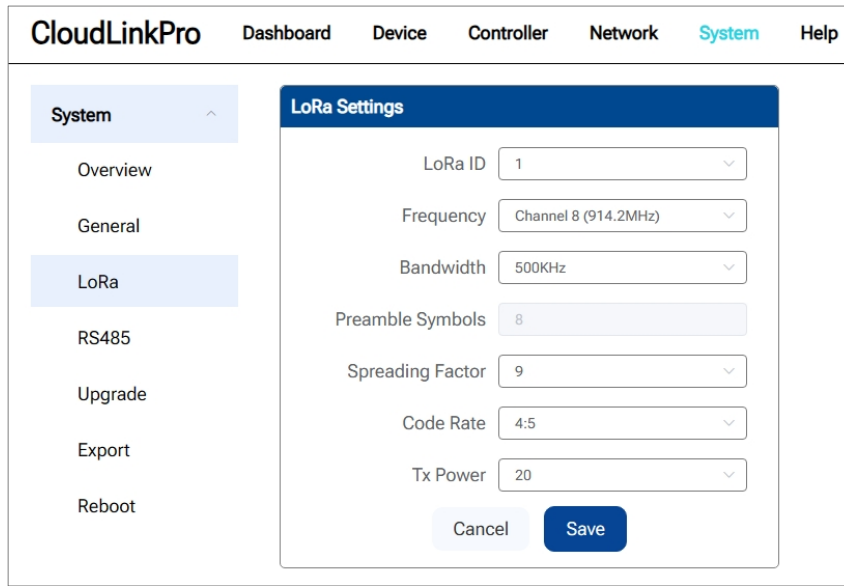

Figure 17 - LoRa Communication Settings

CloudLink runs a proprietary protocol over the LoRa link where each LoRa device obtains a unique LoRa ID from CloudLink automatically and each LoRa packet has its own LoRa ID as its identity together with the part number, serial number and process value of the device connected to the LoRa network. All connected devices are displayed on the LoRa device page, as shown in Figure 18.

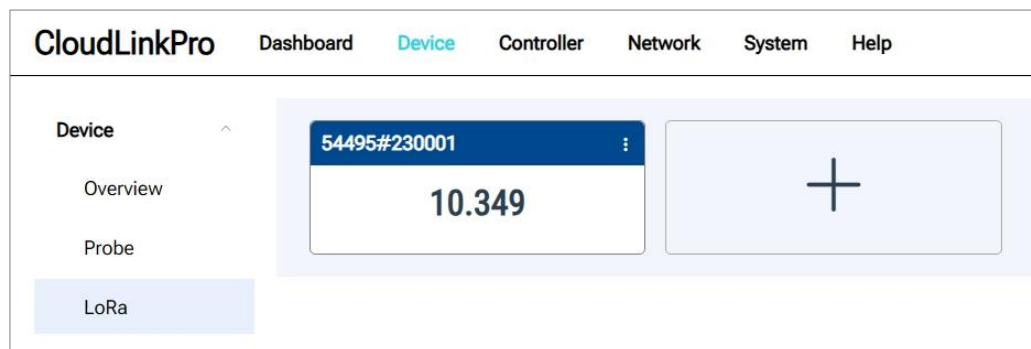

Figure 18 - LoRa Devices Dashboard

2.3.6 Configure Network

The CloudLink device has two wired Ethernet ports, one Wireless Interface and one Cellular Interface. The following chapters depict the procedure to configure those network interfaces to be able to push data to a cloud server or configure settings over the Wi-Fi link.

2.3.6.1 Configure Wired Network

CloudLink has two Ethernet ports, **LAN** port and **WAN** port. The WAN port is designed to connect to an external network, (e.g., office network). The LAN port is programmed to create a local area network centered around the CloudLink, it offers DHCP server functions therefore any network device connected to LAN port will be assigned an IP address and the CloudLink becomes a network gateway for this device to access an external network.

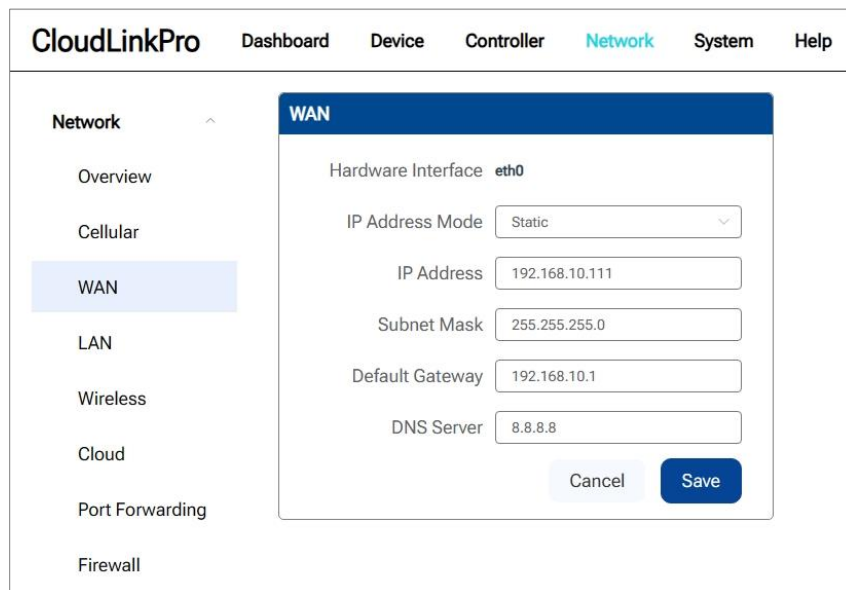

The screenshot shows the CloudLinkPro web interface. The top navigation bar includes 'Dashboard', 'Device', 'Controller', 'Network' (highlighted), 'System', and 'Help'. On the left, a 'Network' menu is expanded, showing options: Overview, Cellular, WAN (selected), LAN, Wireless, Cloud, Port Forwarding, and Firewall. The main content area is titled 'WAN' and displays the following configuration fields:

- Hardware Interface: eth0
- IP Address Mode: Static (dropdown menu)
- IP Address: 192.168.10.111
- Subnet Mask: 255.255.255.0
- Default Gateway: 192.168.10.1
- DNS Server: 8.8.8.8

At the bottom right of the configuration area are 'Cancel' and 'Save' buttons.

Figure 19 - Configure WAN Port

As shown in Figure 19, you can set a Static IP for the **WAN** port or choose DHCP method to obtain an IP address for the WAN port. ***NOTE*** If DHCP is enabled, click [Network->Overview](#) to display the WAN port IP address.

For the **LAN** port, it is highly recommended to not change its settings, connect your device to the LAN port just like you would connect it to a commercial network router.

2.3.6.2 Configure Wireless Network

The CloudLink Wireless interface can be set to **AP** mode or **Station** mode. When set to **AP** mode, its default SSID is **CloudLinkPro**, default Wi-Fi password is **wifi1234**. Users may change the SSID and Wi-Fi password as shown in Figure 20.

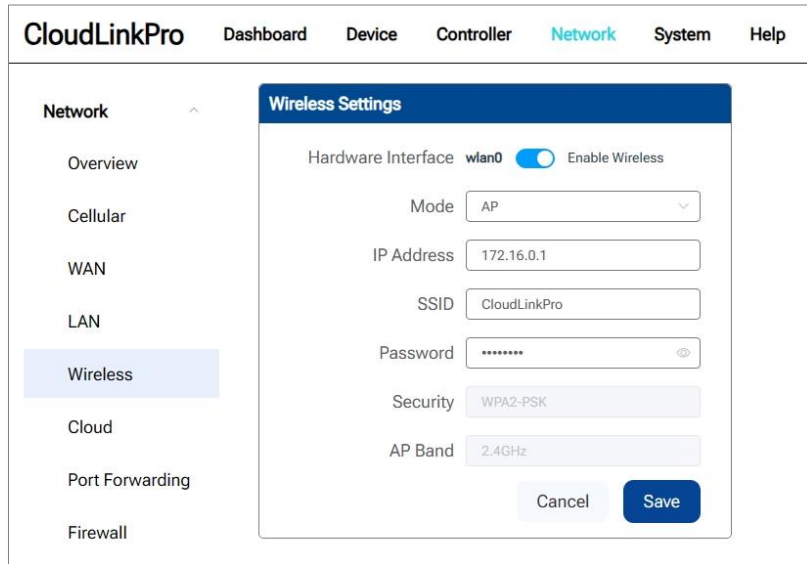

The screenshot shows the CloudLinkPro interface with the 'Network' menu open and 'Wireless' selected. The 'Wireless Settings' dialog is displayed, showing the following configuration:

- Hardware Interface: wlan0
- Enable Wireless:
- Mode: AP
- IP Address: 172.16.0.1
- SSID: CloudLinkPro
- Password: [masked]
- Security: WPA2-PSK
- AP Band: 2.4GHz

Buttons for 'Cancel' and 'Save' are visible at the bottom right of the dialog.

Figure 20 - Configure Wireless AP Mode

If set to **Station** mode, please specify station SSID and password as shown in Figure 21. Once the CloudLink Wi-Fi is connected to your local wireless station, its IP address, gateway address and connection status will be displayed.

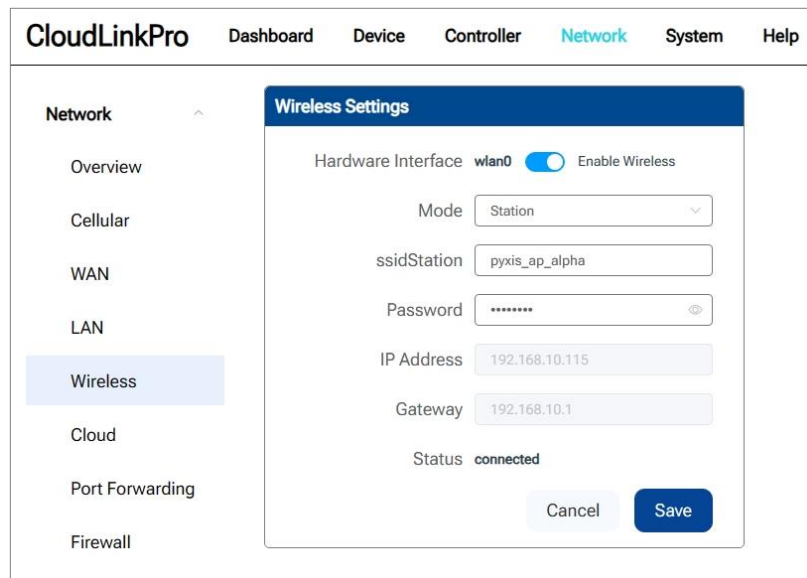

The screenshot shows the CloudLinkPro interface with the 'Network' menu open and 'Wireless' selected. The 'Wireless Settings' dialog is displayed, showing the following configuration:

- Hardware Interface: wlan0
- Enable Wireless:
- Mode: Station
- ssidStation: pyxis_ap_alpha
- Password: [masked]
- IP Address: 192.168.10.115
- Gateway: 192.168.10.1
- Status: connected

Buttons for 'Cancel' and 'Save' are visible at the bottom right of the dialog.

Figure 21 - Configure Wireless Station Mode

2.3.6.3 Configure Cloud Interface

The CloudLink device supports uploading data to various Cloud platforms including standard Pyxis Cloud™, data read from Pyxis probes or 3rd party probes via Modbus RTU, data read from external PLC/controllers via Modbus TCP and data received from LoRa devices can be packaged in accordance with cloud requirements and pushed to the cloud server via Cellular link. As shown in Figure 22, please pick up the **Cloud Platform** first, the **Server URL** is updated automatically with the cloud platform selection however users can make further changes whenever appropriate. **Protocol**, **Require Authentication** and **Topic** are also determined by the cloud platform selection, and they cannot be changed. If Require Authentication is Yes, please further specify the **Username** and **Password**. Finally, please specify **Data Upload Interval** to the cloud platform and **Data Fetch Interval** from various device input sources (for instance, data read from Pyxis probes). ***NOTE*** It is important to make sure the **Data Upload Interval** is **GREATER** than **Data Fetch Interval**.

The screenshot displays the CloudLinkPro web interface. The top navigation bar includes 'Dashboard', 'Device', 'Controller', 'Network' (highlighted), 'System', and 'Help'. On the left, a sidebar menu lists 'Network' (expanded), 'Overview', 'Cellular', 'WAN', 'LAN', 'Wireless', 'Cloud' (selected), 'Port Forwarding', and 'Firewall'. The main content area is titled 'Cloud Server Settings' and contains the following configuration options:

- Enable Cloud Service:
- Cloud Platform: Pyxis Cloud (dropdown)
- Server URL: mqtt.pyxis-cloud.com (text input)
- Server Port: 8883 (text input)
- Protocol: Pyxis MQTT (dropdown)
- Require Authentication: Yes (dropdown)
- Topic: pyxis/{sn}/livedata (text input)
- Username: pyxis (text input)
- Password: [masked] (password input)
- Data Upload Interval: 60 (text input) with a 'sec' unit selector
- Data Fetch Interval: 60 (text input) with a 'sec' unit selector

At the bottom of the settings panel are 'Cancel' and 'Save' buttons.

Figure 22 - Configure Cloud Interface

2.3.6.4 Configure Port Forwarding

The Port Forwarding function is essential for remote monitoring and control. It enables users to connect to field devices over the Internet in a secure manner, as shown in Figure 23.

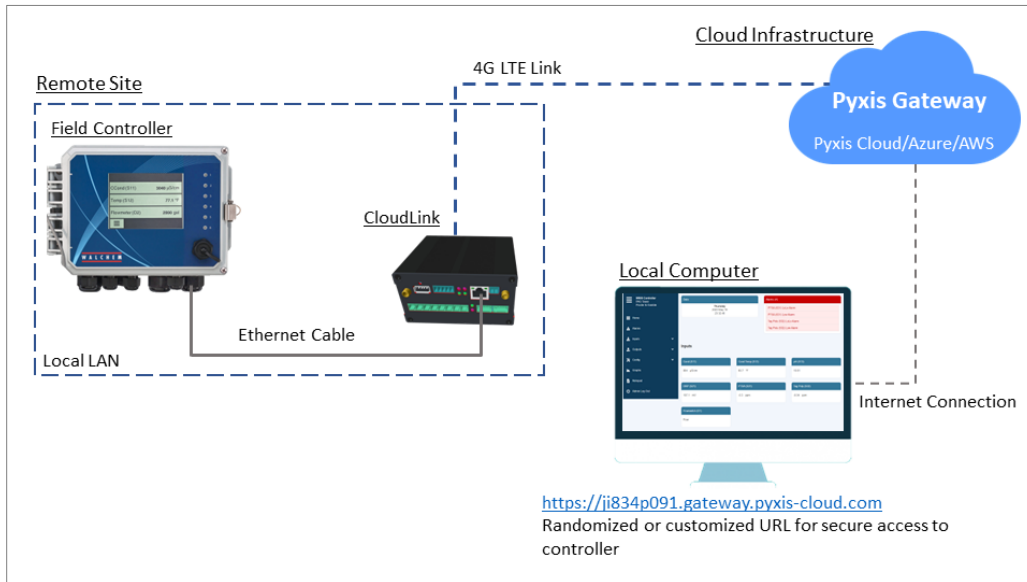

Figure 23 - Port Forwarding Diagram

The Pyxis CloudLink device and the Pyxis Gateway server work seamlessly to relay external requests from the customer's local device to the Pyxis Gateway server and CloudLink device, further to the field device, e.g., a controller for water treatment applications. Multiple port forwarding rules can be created within the CloudLink device. Click the **Add Rule** link in the upper-right corner of Port Forwarding page to start creating a new port forwarding rule as shown in Figure 24. Each port forwarding rule is associated with a network device connected with CloudLink and an application runs on that network device. Therefore, the following settings need to be defined when creating a new rule.

- **Application** - Defines the application name associated with the rule
- **Protocol** - Defines network protocol for the application (e.g., http, ftp or Modbus TCP)
- **External Interface** - Defines where the external request comes from (Cellular, WAN or Wi-Fi. Please select Cellular if configuring remote access via Pyxis Gateway)
- **External Port** - External port for the application (any value above 1024 is OK)
- **Internal IP** - IP address of internal device (e.g., controller IP address)
- **Internal Port** - Port of the internal device (e.g., port 80 for controller http application)

The image shows a configuration window titled "Add Port Forwarding Rule". It contains the following fields and values:

Field	Value
Application	19
Protocol	http
External Interface	Cellular
External Port	8080
Internal IP	192.168.0.10
Internal Port	80

At the bottom of the form, there are two buttons: "Cancel" and "Add".

Figure 24 - Port Forwarding Configurations

Once the rule settings being saved, CloudLink will start to build a network tunnel with the Pyxis Gateway server and with just a few clicks in the Pyxis Gateway server web interface, the user is able to access the remote device and its applications. This manual will cover the Pyxis Gateway configuration in Chapter 3.

2.3.6.5 Configure Firewall

Firewall is another important built-in feature of CloudLink, as it is the gatekeeper of cyber security. A properly configured firewall will block any unauthorized access to the CloudLink device as well as any devices network connected via CloudLink, but will also enable authorized access to the desired network resource attached to CloudLink.

CloudLink is capable of controlling ingress, egress and internal network traffic to provide flexibilities to permit/deny incoming network requests from Cellular, WAN and Wireless interface; to permit/deny outgoing network packets from Cellular, WAN and Wireless interface to specific IPs; in addition, to permit/deny network packets among CloudLink's network interfaces, e.g., any network requests initiated from LAN interface cannot reach WAN interface.

Please follow the following pictures to configure inbound, outbound and internal network firewall.

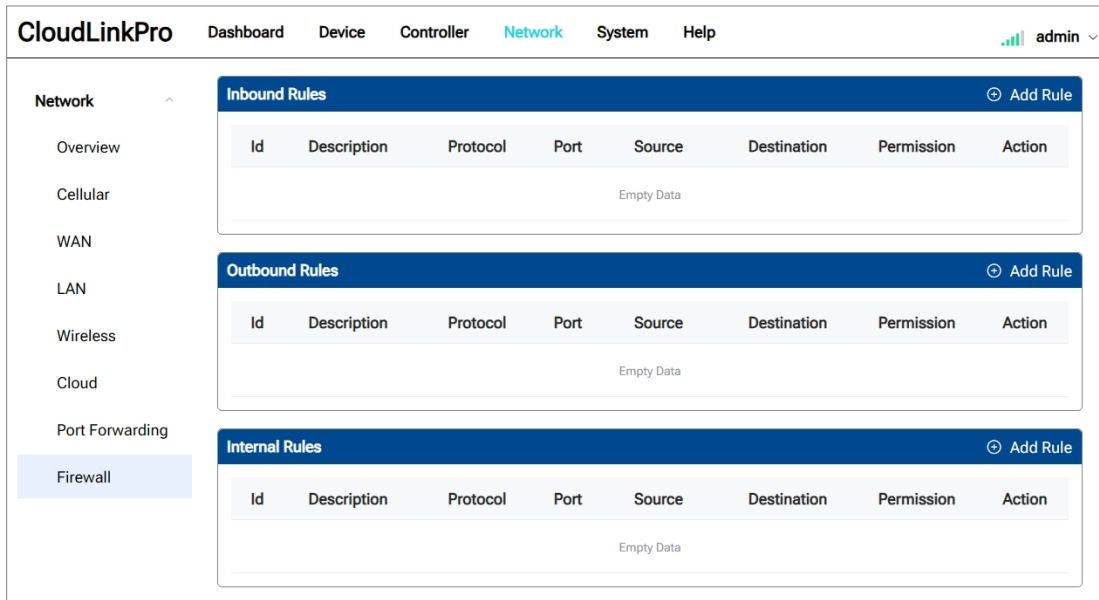

Figure 25 - Firewall Settings Dashboard

Click **Add Rule** in each section to create a new firewall rule, for each rule the user needs to configure the Application Description, Protocol and Port, Network Interface, Source and Destination and finally attach the access policy to the firewall rule by selecting **Allow** or **Deny**.

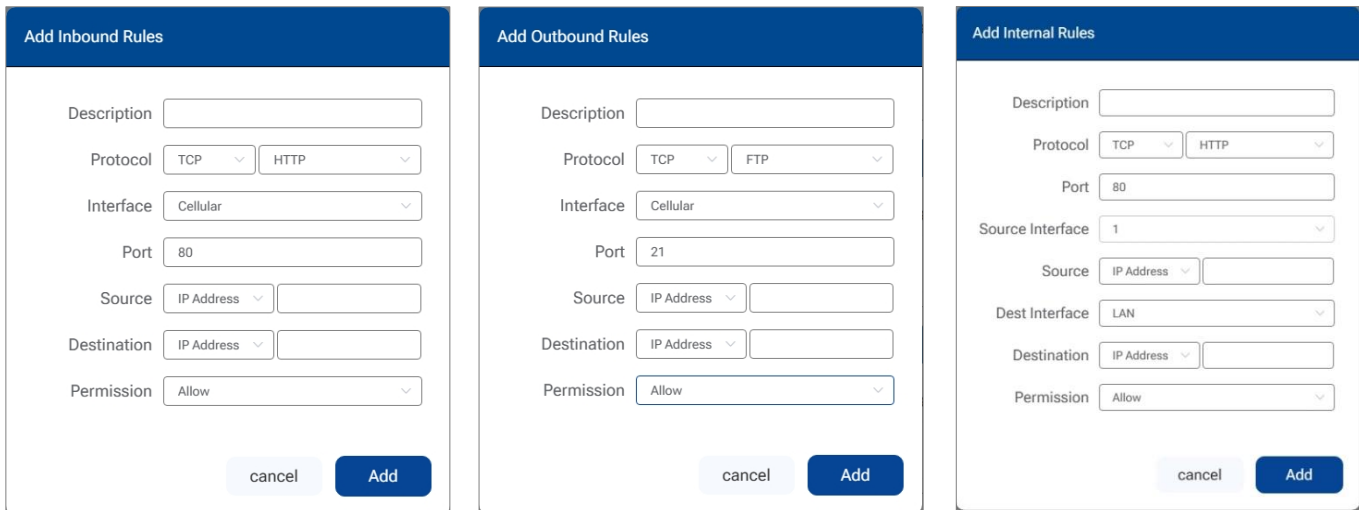
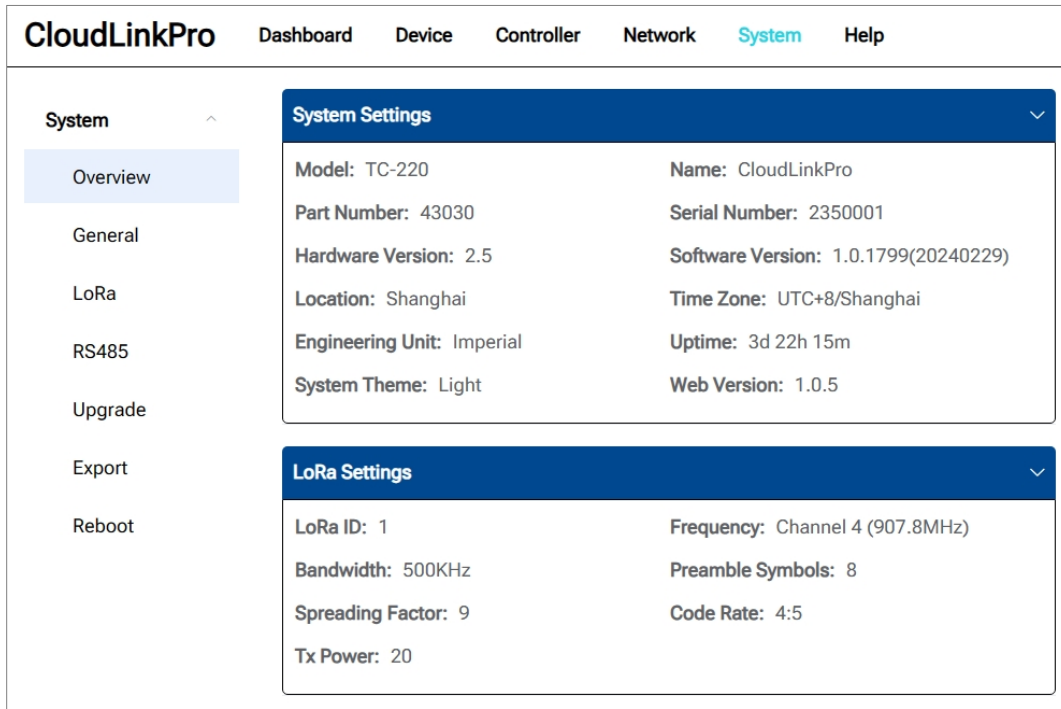

Figure 26 - Inbound/Outbound/Internal Firewall Setup

2.3.7 System Configuration & Control

CloudLink System Settings, LoRa and Modbus RS485 communication settings will be displayed in the System Overview page as shown in Figure 27. The following chapters will depict various aspects of system configurations and controls via the System menu.



System Settings	
Model: TC-220	Name: CloudLinkPro
Part Number: 43030	Serial Number: 2350001
Hardware Version: 2.5	Software Version: 1.0.1799(20240229)
Location: Shanghai	Time Zone: UTC+8/Shanghai
Engineering Unit: Imperial	Uptime: 3d 22h 15m
System Theme: Light	Web Version: 1.0.5

LoRa Settings	
LoRa ID: 1	Frequency: Channel 4 (907.8MHz)
Bandwidth: 500KHz	Preamble Symbols: 8
Spreading Factor: 9	Code Rate: 4:5
Tx Power: 20	

Figure 27 - CloudLink System Overview

2.3.7.1 Configure General Settings

Users are allowed to set the CloudLink device name, location, time zone, engineering unit, system time and language of the UI as shown in Figure 28. Changes to those settings will take effect immediately once the **Save** button is clicked.

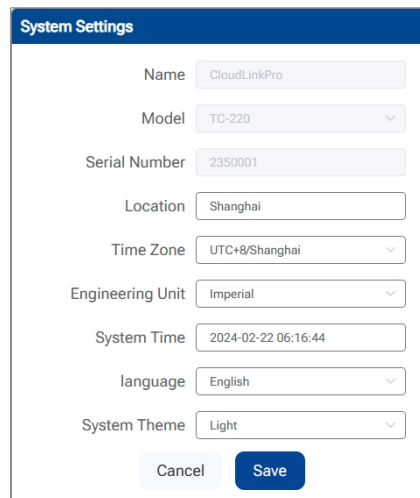

System Settings	
Name	CloudLinkPro
Model	TC-220
Serial Number	2350001
Location	Shanghai
Time Zone	UTC+8/Shanghai
Engineering Unit	Imperial
System Time	2024-02-22 06:16:44
language	English
System Theme	Light

Cancel Save

Figure 28 - Configure General Settings

2.3.7.2 Configure LoRa Communication Settings

If there are multiple LoRa-enabled CloudLink devices in the same area, be sure to set different LoRa IDs for them, as shown in Figure 29. The frequency, bandwidth, spreading factor, and code rate of all LoRa devices communicating with the CloudLink device should be set to the same values as CloudLink. In addition, if the distance between the LoRa device (e.g., Pyxis Radar Level Sensor with LoRa communication) and the CloudLink device increases, set the Spreading Factor to a larger value (e.g., 12).

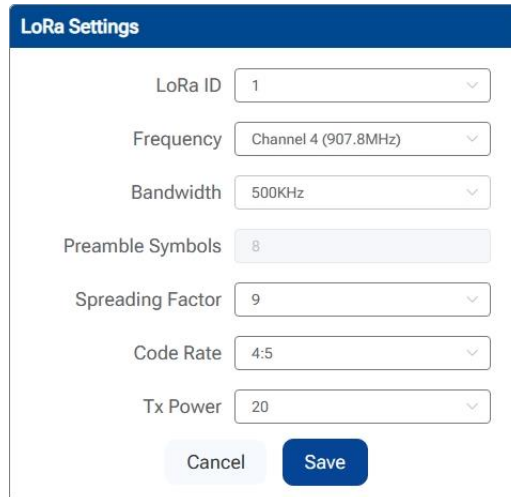

Figure 29 - Configure LoRa Communications

2.3.7.3 Configure Modbus RTU Communication Settings

CloudLink has one RS485 interface for collecting data from Pyxis digital probes and any other 3rd party probes that support Modbus RTU. In the RS485 configuration page, users can specify communication parameters such as Baudrate and Parity, however Databits is fixed at 8 and Stopbit is fixed as 1. ***NOTE*** At the time of writing this manual, CloudLink device only supports Modbus RTU master mode. Future CloudLink software upgrade may support Modbus RTU slave mode.

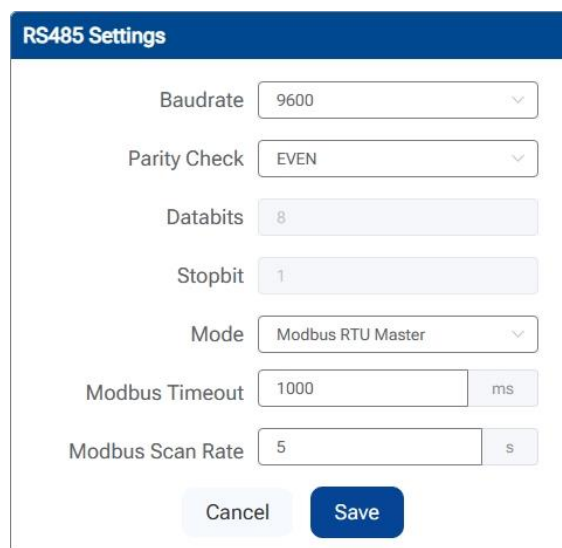

Figure 30 - Configure LoRa Communications

2.3.7.4 Software Upgrade

CloudLink supports software upgrade over web interface, please follow the on-screen menu to check latest software version and upgrade to the new version.

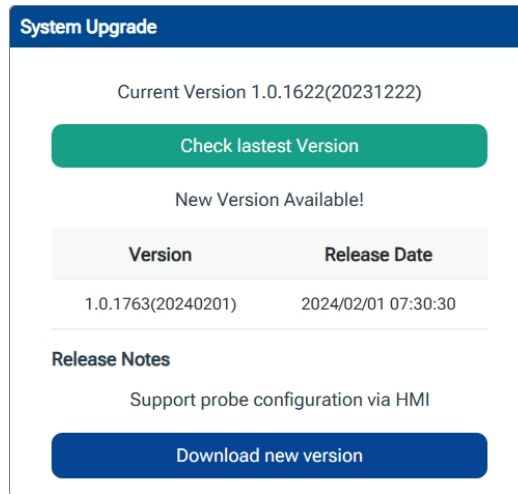

Figure 31 - Software Upgrade

2.3.7.5 Import/Export Configurations

Being able to export system configurations and import to another CloudLink device is convenient for copying same configurations across different devices. Click the **Download** button as shown in Figure 32 to download system configurations into your local computer; click **Select File** button to choose CloudLink system configuration file from your local computer and then click **Upload** button to upload file to the CloudLink device to overwrite existing configuration file.

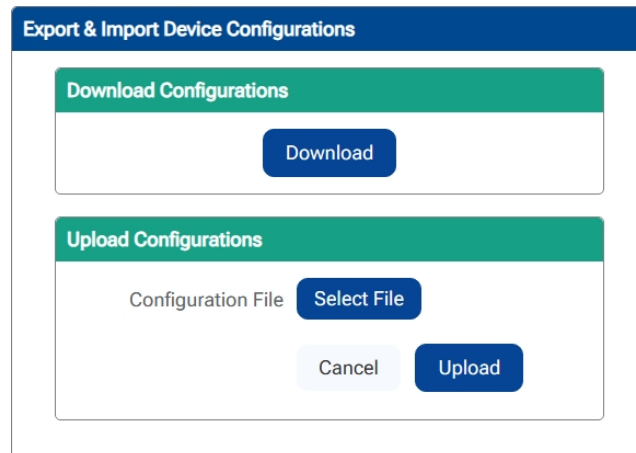

Figure 32 - Export/Import System Configurations

3 Pyxis Gateway Service

Pyxis Gateway is a web portal to manage your CloudLink device. With Pyxis Gateway service, the customer is able to connect to the CloudLink device and field devices remotely. Please contact service@pyxis-lab.com to request your Pyxis Gateway login credential if you have purchased a CloudLink device. Visit <https://gateway.pyxis-cloud.com> to login to the Pyxis Gateway web portal and pickup an online device that you want connected to as shown in Fig 33.



Figure 33 - Pyxis Gateway device list

3.1 Activate Remote Connection

By default, remote connection is disabled for each CloudLink device before it is shipped to our customers. However, you can enable the remote connection via Pyxis Gateway web interface by following Figure 34 and Figure 35.

Select the device in the device list page as shown in Figure 32, click the refresh button right side of APP List to load the application list that you have configured in CloudLink port forwarding setup page as described in chapter 2.3.6.4.

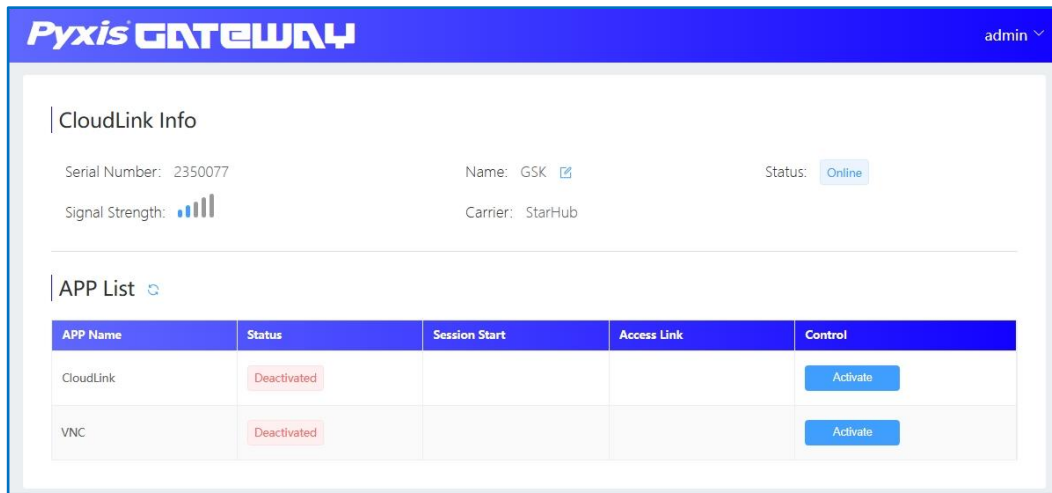

Figure 34 - Activate Remote Connection

Then click the Activate button that associates with the application that you want access to; you may choose to give the remote access a customized link name or use a randomized link name in the popup window, the default link name is **SN.gateway.pyxis-cloud.com**, where **SN** is CloudLink's serial number. Please note, the complete link will always end with **.gateway.pyxis-cloud.com**

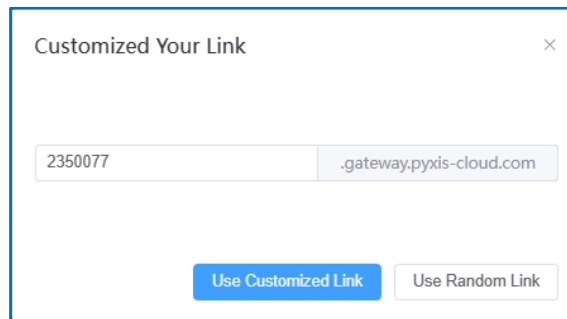

Figure 35 - Customize Remote Connection Link

There will be an Open button generated automatically if the remote connection is built successfully and the application type is HTTP or HTTPS (e.g., controller web application). Click the **Open** button, your web browser will load the remote device web page automatically.

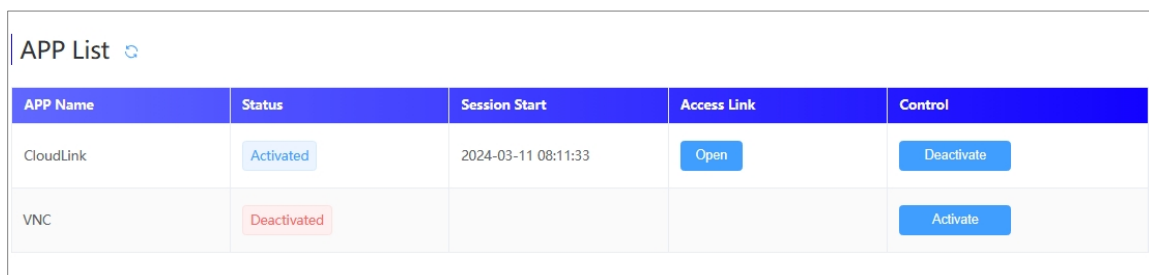

Figure 36 - Remote Connection Activated

4 Application Example

4.1 General Gateway

Connect CloudLink with the field controller through RS485 or Ethernet Port, CloudLink collects data from the controller and uploads it to Pyxis Cloud as requested.

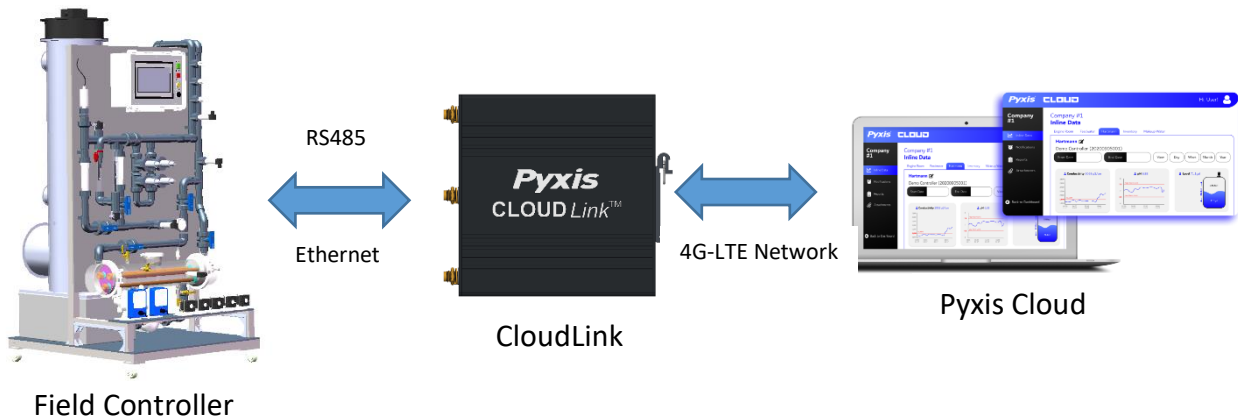

Figure 37 - General Connection Diagram

4.2 Gateway for Pyxis Sensors via RS485

CloudLink can seamlessly collect the data from all Pyxis sensors through RS485 and upload to Pyxis Cloud.

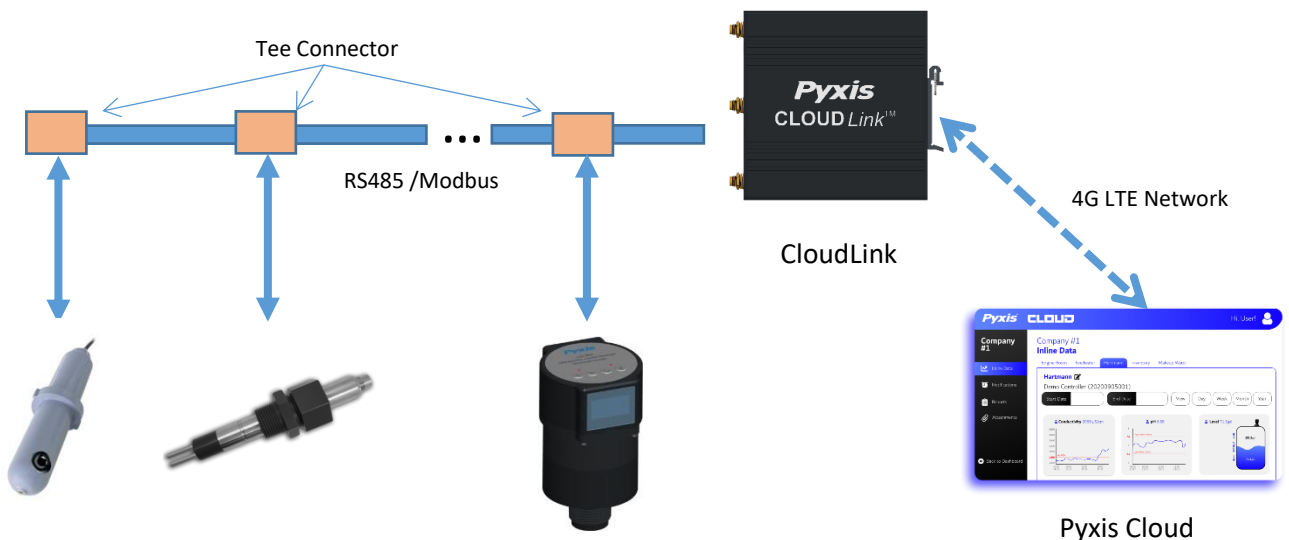

Figure 38 - Pyxis Sensor Connection Diagram

4.3 Gateway for Pyxis Sensors via LoRa

CloudLink can seamlessly collect the data from all Pyxis LoRa-enabled sensors through LoRa and upload to Pyxis Cloud

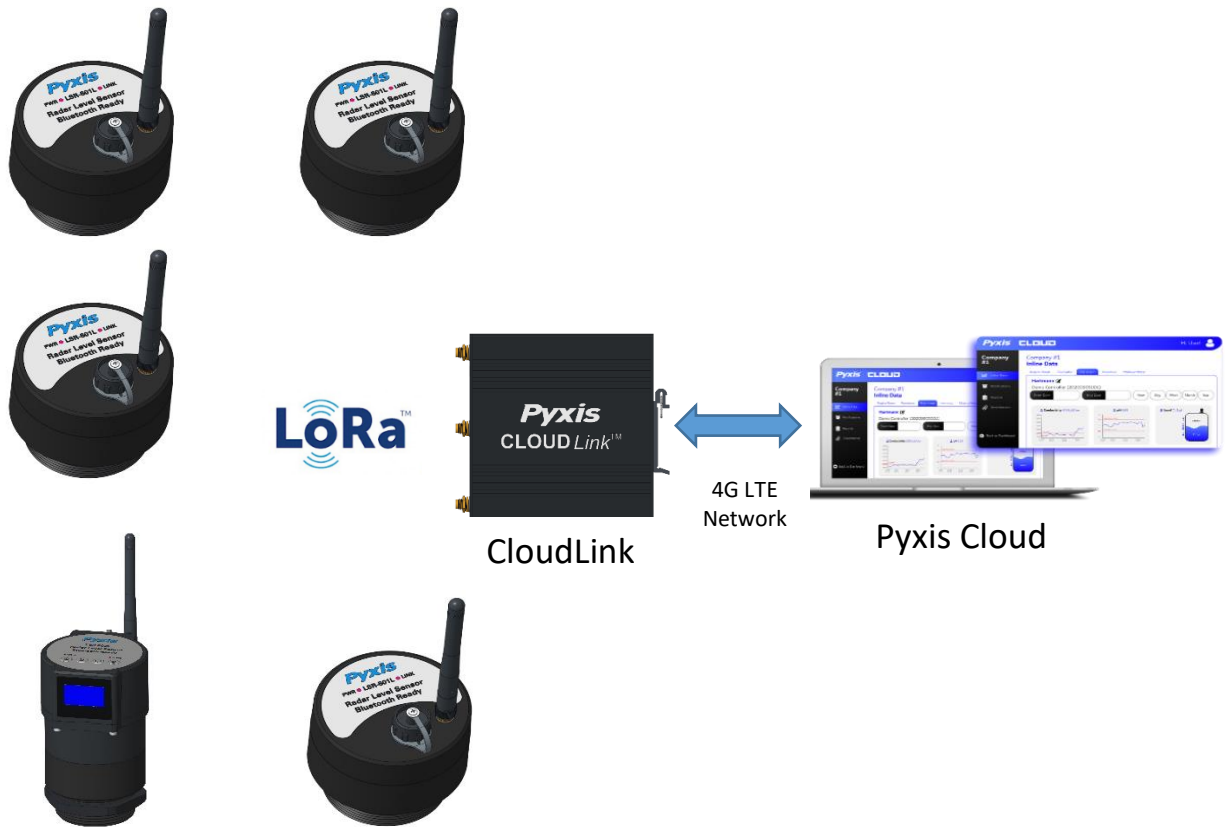

Figure 39 - Pyxis LoRa Devices Connection Diagram

5 Dimension (inch/mm)

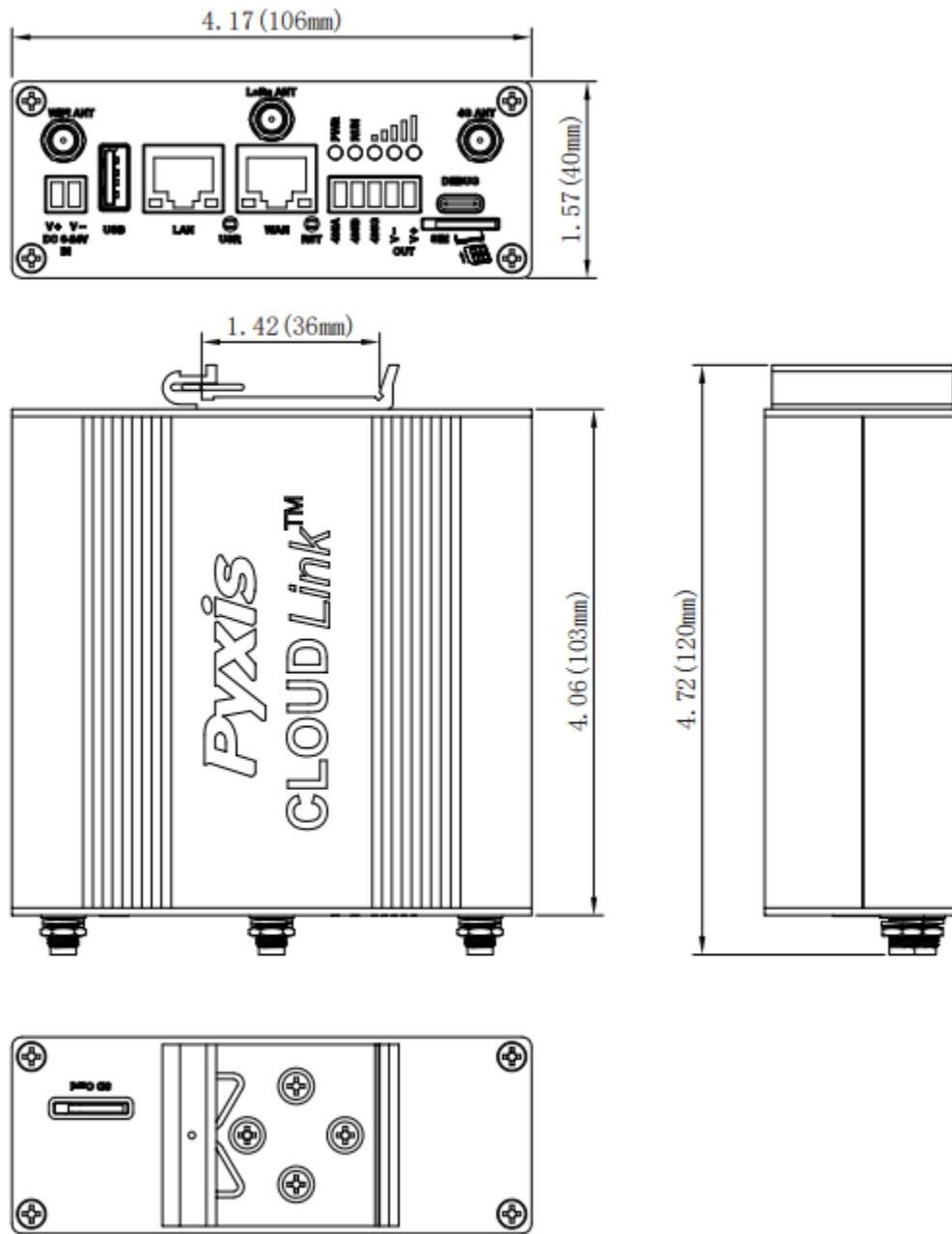

Figure 40 - Dimension of CloudLink Enclosure (unit: inch/mm)

6 Appendix

6.1 CloudLink Modbus Register Definition

6.1.1 System Info

Register	Address	Permissions	Data Type	Example
model	x1001	READ	char[16]	CloudLinkPro
name	x1009	READ	char[16]	South Tower
pn	x1017	READ	UINT32	43035
sn	x1019	READ	char[16]	230012
hardware version	x1027	READ	char[16]	v2.0
software version	x1035	READ	char[32]	v2.0.672
location	x1051	READ	char[16]	Shanghai
timezone	x1059	READ	INT16	8
engineering unit	x1060	READ	INT16	2
theme	x1061	READ	char[16]	Light
uptime	x1069	READ	UINT32	3992
command	x1071	WRITE/READ	UINT16	1

6.1.2 Cellular Info

Register	Address	Permissions	Data Type	Example
Brand	x4001	READ	char[16]	Quectel
Module	x4009	READ	char[16]	EG25G
Carrier	x4017	READ	char[32]	AT&T
Signal	x4033	READ	UINT16	17
IP	x4034	READ	char[16]	10.236.122.179
Gateway	x4042	READ	char[16]	10.64.64.64

6.1.3 Probe Readings

Object	Value	Name	Unit	Decimal
Data Type	FLOAT32 CDAB	char[32]	char[16]	UINT16
Permissions	READ	READ/WRITE	READ/WRITE	READ/WRITE
Probe 1	x2001	x2101	x2501	x2701
Probe 2	x2003	x2117	x2509	x2702
Probe 3	x2005	x2133	x2517	x2703
Probe 4	x2007	x2149	x2525	x2704
Probe 5	x2009	x2165	x2533	x2705
Probe 6	x2011	x2181	x2541	x2706
Probe 7	x2013	x2197	x2549	x2707
Probe 8	x2015	x2213	x2557	x2708
Probe 9	x2017	x2229	x2565	x2709
Probe 10	x2019	x2245	x2573	x2710
Probe 11	x2021	x2261	x2581	x2711
Probe 12	x2023	x2277	x2589	x2712

Probe 13	x2025	x2293	x2597	x2713
Probe 14	x2027	x2309	x2605	x2714
Probe 15	x2029	x2325	x2613	x2715
Probe 16	x2031	x2341	x2621	x2716
Probe 17	x2033	x2357	x2629	x2717
Probe 18	x2035	x2373	x2637	x2718
Probe 19	x2037	x2389	x2645	x2719
Probe 20	x2039	x2405	x2653	x2720

6.1.4 LoRa Readings

Object	Value	Name	Unit	Decimal
Data Encoding	FLOAT32 CDAB	char[32]	char[16]	UINT16
Permissions	READ	READ	READ	READ
Lora 1 Reading 1	x3001	x3101	x3401	x3701
Lora 2 Reading 1	x3003	x3117	x3409	x3702
Lora 3 Reading 1	x3005	x3133	x3417	x3703
Lora 4 Reading 1	x3007	x3149	x3425	x3704
Lora 5 Reading 1	x3009	x3165	x3433	x3705
Lora 6 Reading 1	x3011	x3181	x3441	x3706
Lora 7 Reading 1	x3013	x3197	x3449	x3707
Lora 8 Reading 1	x3015	x3213	x3457	x3708
Lora 1 Reading 2	x3017	x3229	x3465	x3709
Lora 2 Reading 2	x3019	x3245	x3473	x3710
Lora 3 Reading 2	x3021	x3261	x3481	x3711
Lora 4 Reading 2	x3023	x3277	x3489	x3712
Lora 5 Reading 2	x3025	x3293	x3497	x3713
Lora 6 Reading 2	x3027	x3309	x3505	x3714
Lora 7 Reading 2	x3029	x3325	x3513	x3715
Lora 8 Reading 2	x3031	x3341	x3521	x3716

6.1.5 Controller Readings

Object		Value	Name	Unit
Data Encoding		FLOAT32 CDAB	char[32]	char[16]
Permissions		READ	READ	READ
Controller 1	Input 1	x5001	x6001	x8001
	Input 2	x5003	x6017	x8009
	Input 3	x5005	x6033	x8017
	Input 4	x5007	x6049	x8025
	Input 5	x5009	x6065	x8033
	Input 6	x5011	x6081	x8041
	Input 7	x5013	x6097	x8049
	Input 8	x5015	x6113	x8057
	Input 9	x5017	x6129	x8065
	Input 10	x5019	x6145	x8073
	Input 11	x5021	x6161	x8081

	Input 12	x5023	x6177	x8089
	Input 13	x5025	x6193	x8097
	Input 14	x5027	x6209	x8105
	Input 15	x5029	x6225	x8113
	Input 16	x5031	x6241	x8121
Controller 2	Input 1	x5033	x6257	x8129
	Input 2	x5035	x6273	x8137
	Input 3	x5037	x6289	x8145
	Input 4	x5039	x6305	x8153
	Input 5	x5041	x6321	x8161
	Input 6	x5043	x6337	x8169
	Input 7	x5045	x6353	x8177
	Input 8	x5047	x6369	x8185
	Input 9	x5049	x6385	x8193
	Input 10	x5051	x6401	x8201
	Input 11	x5053	x6417	x8209
	Input 12	x5055	x6433	x8217
	Input 13	x5057	x6449	x8225
	Input 14	x5059	x6465	x8233
	Input 15	x5061	x6481	x8241
	Input 16	x5063	x6497	x8249
Controller 3	Input 1	x5065	x6513	x8257
	Input 2	x5067	x6529	x8265
	Input 3	x5069	x6545	x8273
	Input 4	x5071	x6561	x8281
	Input 5	x5073	x6577	x8289
	Input 6	x5075	x6593	x8297
	Input 7	x5077	x6609	x8305
	Input 8	x5079	x6625	x8313
	Input 9	x5081	x6641	x8321
	Input 10	x5083	x6657	x8329
	Input 11	x5085	x6673	x8337
	Input 12	x5087	x6689	x8345
	Input 13	x5089	x6705	x8353
	Input 14	x5091	x6721	x8361
	Input 15	x5093	x6737	x8369
	Input 16	x5095	x6753	x8377
Controller 4	Input 1	x5097	x6769	x8385
	Input 2	x5099	x6785	x8393
	Input 3	x5101	x6801	x8401
	Input 4	x5103	x6817	x8409
	Input 5	x5105	x6833	x8417
	Input 6	x5107	x6849	x8425
	Input 7	x5109	x6865	x8433
	Input 8	x5111	x6881	x8441

	Input 9	x5113	x6897	x8449
	Input 10	x5115	x6913	x8457
	Input 11	x5117	x6929	x8465
	Input 12	x5119	x6945	x8473
	Input 13	x5121	x6961	x8481
	Input 14	x5123	x6977	x8489
	Input 15	x5125	x6993	x8497
	Input 16	x5127	x7009	x8505

7 REGULATORY APPROVAL

United States

The TC-220 CloudLink™ has been tested and found to comply with the limits for a Class B digital device, pursuant to part 15 of the FCC Rules. These limits are designed to provide reasonable protection against harmful interference in a residential installation. This equipment generates, uses and can radiate radio frequency energy, and if not installed and used in accordance with the instructions, may cause harmful interference to radio communications. However, there is no guarantee that interference will not occur in an installation. If this equipment does cause harmful interference to radio or television reception, which can be determined by turning the equipment off and on, the user is encouraged to try to correct the interference by one or more of the following measures:

- Reorient or relocate the receiving antenna.
- Increase the separation between the equipment and receiver.
- Connect the equipment into an outlet on a circuit different from that to which the receiver is connected.
- Consult the dealer or an experienced radio/TV technician for help

Canada

This device complies with Industry Canada license exempt RSS standard(s). Operation is subject to the following two conditions: (1) this device may not cause interference, and (2) this device must accept any interference, including interference that may cause undesired operation of the device.

Le présent appareil est conforme aux CNR d'Industrie Canada applicables aux appareils radio exempts de licence. L'exploitation est autorisée aux deux conditions suivantes: (1) l'appareil ne doit pas produire de brouillage, et (2) l'utilisateur de l'appareil doit accepter tout brouillage radioélectrique subi, même si le brouillage est susceptible

Contact us

Contact us if you have questions about the use or maintenance of the TC-220 CloudLink™

Pyxis Lab, Inc.

21242 Spell Circle Dr.
Tomball, TX 77375 USA
1-866-203-8397

www.pyxis-lab.com
order@pyxis-lab.com
service@pyxis-lab.com