

Pyxis®



As an organization founded & built by former water treatment professionals, we understand the day-to-day operations & struggles of being in the field. That is why we are devoted to developing cutting-edge, water treatment technology with a robustness for Expanded Ranges, Lower Detection Limits & Easier User Operation.

2024

Product Catalog

© Copyright 2024 Pyxis Lab, Inc.

Introduction

Founded in 2012 by Dr. Caibin Xiao, Pyxis Lab® Inc. came from humble beginnings in Holliston, Massachusetts. After a few short years, our company has grown tremendously & is currently operating a **Global Headquarters near Houston, Texas** with locations in **Barcelona, Spain** as well as **Shanghai & Changzhou, China**.

Now – thanks to all of our distribution partners, OEM controller partners and customers – Pyxis Lab® Inc. is the leading manufacturer of inline monitoring technology for Fluorescent Tracing Chemicals. Our unique inline sensors and control packages offer flexible integration with an ‘agnostic’ approach to the market. Capable of communicating with any receiving device in both analog and digital (Modbus) formats with Bluetooth wireless configuration, diagnostics, and calibration via the uPyxis® Mobile & Desktop app.

Our products have been installed in over 15,000 locations across multiple industries within the last eight years. With each of these installations, we improve the customers operations by controlling chemical dosing, process control and delivering higher productivity while reducing the environmental impact of water & process treatment operations. Our products are designed by an experienced team of former water treatment professionals. Amounting to greater than 75 years of combined experience in the industry with many global water treatment companies. We combine a broad range of the latest chemical, material, optical, and electronic technologies to enable you to apply water and process treatment products more accurately and effectively than EVER before.

As an organization **founded & built by former water treatment professionals**, we understand the day-to-day operations & struggles of being in the field. That is why we are **devoted to developing cutting-edge technology** with a robustness for **Expanded Device Ranges, Lower Detection Limits & Easier User Operation**.

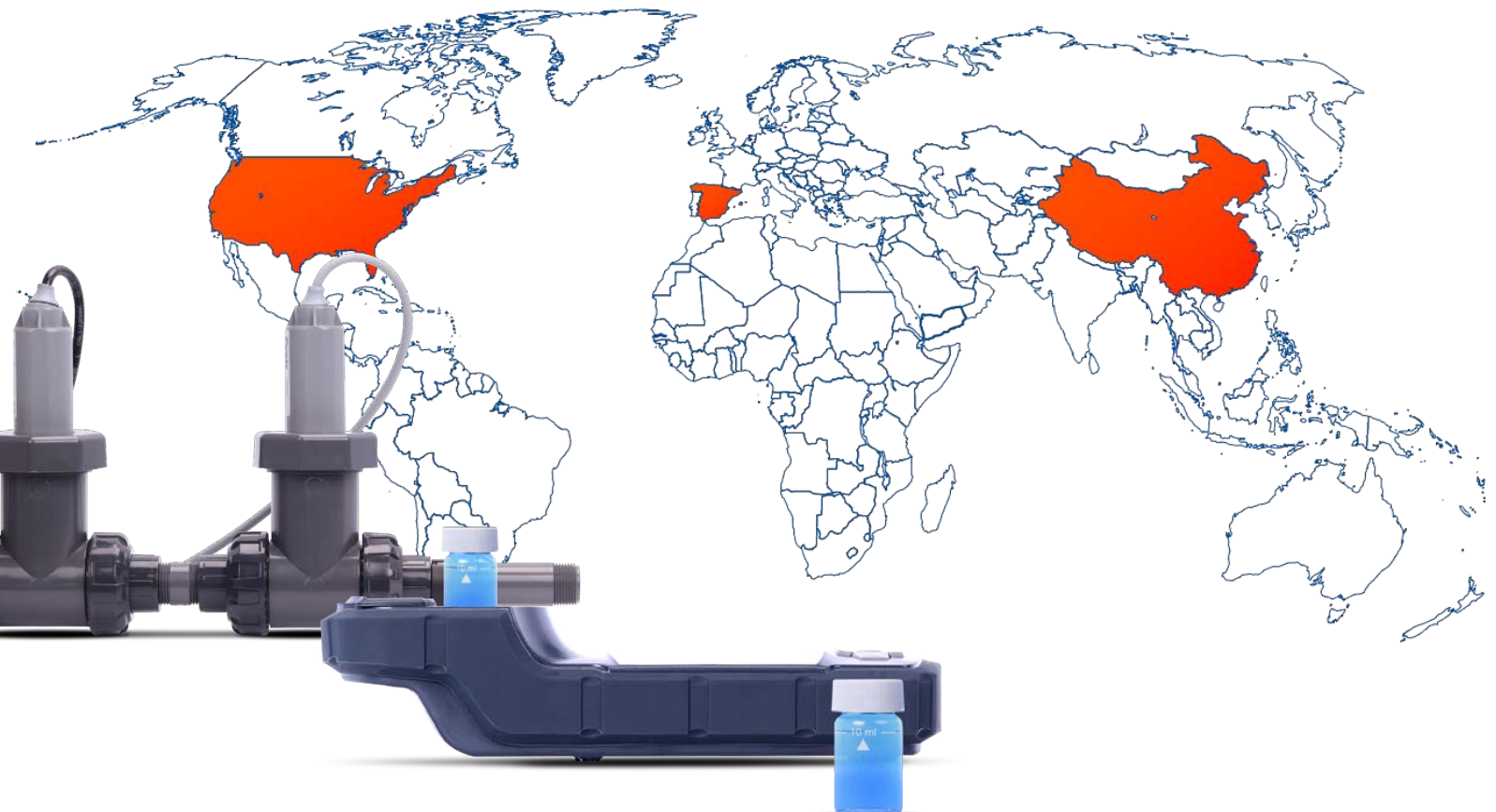



Handheld Devices

pages 4–19



Inline Sensors

pages 20–45



Corrosion Sensors

pages 46–49



Level Sensors

pages 50–61



Panel Solutions

pages 62–83



Chemicals & Accessories

pages 84–101



Software Solutions

pages 102–107



HANDHELD DEVICES

*Portable Fluorometers, Multimeters, Dual Channel Meters, Single Channel Meters and Portable Colorimeters. Pyxis Lab® offers handheld devices that measure for **ALL key water and process parameters** for Industrial, Municipal & Environmental marketplaces.*





SP-350 Fluorometer

Parameters

PTSA

Description

A simple-to-operate, single channel handheld device designed for measuring PTSA only. Ideal for water treaters testing traced cooling water.

Features

- 0–300ppb PTSA Range
- Direct Pour Sample Cell
- Compensates for Color & Turbidity
- Integrated Data Logging
- Large Color Display Screen
- Sample LOCK-IN Capability
- Bluetooth® Ready for uPyxis®



SP-380 Fluorometer

Parameters

PTSA + Fluorescein

Description

A dual channel handheld meter capable of measuring for PTSA & Fluorescein. Ideal for water treaters testing traced cooling & boiler water.

Features

- 0–300ppb PTSA Range
- 0–600ppb Fluorescein Range
- Direct Pour Sample Cell
- Compensates for Color & Turbidity
- Integrated Data Logging
- Large Color Display Screen
- Sample LOCK-IN Capability
- Bluetooth® Ready for uPyxis®



SP-395T Fluorometer

Parameters

Tolytriazole (TTA)

Description

A unique single channel handheld fluorometer that measures Tolytriazole (TTA) as a direct measurement test. **Requires no reagents.**

Features

- 0–10ppm TTA Range
- Direct Pour Sample Cell
- Compensates for Color & Turbidity
- Integrated Data Logging
- Large Color Display Screen
- Sample LOCK-IN Capability
- Bluetooth® Ready for uPyxis®



SP-400 Fluorometer

Parameters

PTSA + Conductivity

Description

A dual channel handheld meter capable of measuring for PTSA & Conductivity. Ideal for water treaters testing traced cooling & desiring Conductivity value simultaneously.

Features

- 0–300ppb PTSA Range
- 0~15,000µS/cm Conductivity Range
- Direct Pour Sample Cell
- Compensates for Color & Turbidity
- Integrated Data Logging
- Large Color Display Screen
- Sample LOCK-IN Capability
- Bluetooth® Ready for uPyxis®

Fluorescent Polymer Handheld Devices

Compete on a world-class level! Our line of proprietary technology offers cutting-edge optical measurement of Fluorescent Polymer. These easy-to-use handheld devices offer the ability to directly measure for Fluorescent Polymer now available on the market for use in cooling & process water treatment chemistries.



SP-350P Fluorometer

Parameters

Fluorescent Polymer

Description

A single channel handheld fluorometer allows users the ability to directly measure for Fluorescent Polymer, with **no reagents required**.

SP-380P Fluorometer

Parameters

PTSA + Fluorescent Polymer

Description

A dual channel handheld fluorometer that allows users the ability to directly measure for Fluorescent Polymer & PTSA, with **no reagents required**.

Features

- 0–20ppm Fluorescent Polymer Range
- 0–300ppb PTSA Range (SP-380P)
- Direct Pour Sample Cell
- Compensates for Color & Turbidity
- Compensates for PTSA Overlap
- Large Color Display Screen
- Sample LOCK-IN Capability
- Bluetooth® Ready for uPyxis®



SP-600 Water Multimeter

Parameters

pH, ORP, Conductivity, Resistivity, Temperature, Free & Total DPD Chlorine (0.02–10ppm). USEPA-334.0 Compliant.

Description

A unique handheld multimeter specifically designed to provide added value and ease of use to the Industrial and Municipal water market users. This military-grade device is capable of instantly measuring for key water treatment parameters and also offers colorimetric Free & Total DPD Chlorine. The simplicity of the one-handed operation is empowered by Pyxis Lab® Inc. proprietary technology that combines electrochemical and optical measurements in a cuvette-less platform. The SP-600 offers Bluetooth® connectivity between pH/ORP module & the base unit making module replacement simple with no tools required. The SP-600 also allows wireless data upload via the uPyxis® app.

Uses Pyxis Lab® or Industry Standard Powder Pillow Reagents for Free/Total Chlorine

Features

- Direct Pour Sample Cell
- Wireless pH/ORP Module
- Conductivity or Resistivity Mode
- 0–200,000µS/cm Expanded Range
- Integrated Colorimeter for DPD Chlorine
- Large Color Display Screen
- Sample LOCK-IN Capability
- Bluetooth® Ready for Wireless Features
- Integrated Data Logging
- Simple pH/ORP Module Swap Out



SP-710 Water Multimeter

Parameters

pH, ORP, Conductivity, Temperature, Free & Total TMB Chlorine

Description

A handheld multimeter that measures 6 key water treatment parameters. Featuring simple one-handed operation with our proprietary wireless pH/ORP module for simple replacement in the field, requiring no tools! The SP-710 displays results under a minute for all key parameters; offers data logging and wireless transfer via the uPyxis® app. Customize PTSA traced product name & display concentration for your specific water treatment product. The SP-710 incorporates a colorimetric Free & Total Chlorine measurement. ELIMINATE wasted service time by measuring all primary cooling traced water treatment parameters with this single device platform.

Offers TMB method for testing Free & Total Chlorine. Provided in a 30mL dropper bottle capable of 230 tests each. NO VIALS NEEDED!

Features

- Direct Pour Sample Cell
- Wireless pH/ORP Module
- Compensates for Color & Turbidity
- Customized Chemical Product Display
- PTSA Direct Read
- Large Color Display Screen
- Sample LOCK-IN Capability
- Free & Total Chlorine Colorimeter
- Integrated Data Logging
- Simple pH/ORP Module Swap Out



SP-710B Water Multimeter

Parameters

pH, ORP, Conductivity, Temperature, PTSA & Fluorescein

Description

A unique handheld multimeter that also measures 6 key water treatment parameters, but offers Fluorescein for boiler water treatment applications instead of Free & Total Chlorine. The SP-710B offers data logging and wireless transfer via the uPyxis® app. Customize PTSA and Fluorescein traced product name & display concentration for your specific water treatment products. ELIMINATE wasted service time by measuring all primary cooling & boiler traced water treatment parameters with this single device platform.

In addition to direct read PTSA for traced cooling water products, the SP-710B offers direct read for Fluorescein traced boiler water treatment products.

Features

- Direct Pour Sample Cell
- Wireless pH/ORP Module
- Compensates for Color & Turbidity
- Customized Chemical Product Display
- PTSA + Fluorescein Direct Read
- Large Color Display Screen
- Sample LOCK-IN Capability
- Bluetooth® Ready for Wireless Features
- Integrated Data Logging
- Simple pH/ORP Module Swap Out



SP-800 Multi-Parameter Colorimeter

Parameters

Offers 7 LED wavelengths & 75+ built-in reagent based test methods, such as Chlorine, Phosphate, Iron, Copper as well as unique Pyxis Lab® test methods: Direct Read Bleach Chlorine Concentration (0-16%), Direct Read Chlorine Dioxide Concentration (7.5–1,500ppm), Cyanide Free Zinc Method & Peracetic Acid (PAA).

Description

A multi-wavelength colorimeter specifically designed & suited for Municipal, Industrial & Environmental water analysis. It arrives pre-calibrated for colorimetric measurements of analyses common in laboratory or field water testing environments. In multiple side-by-side validation and comparison studies, the SP-800 has proven to be statistically more accurate than other devices on the market.

Features

- Bluetooth® Ready for uPyxis® Features
- Add User Defined Methods via uPyxis®
- Wireless Datalog Download, Export & Share
- 7 LED Wavelengths
- 75+ Built-In Reagent Based Test Methods
- Operates with Pyxis Lab® or Industry Standard Liquid/Solid Reagents
- USEPA Compliant Methodology



SP-910 Portable Water Analyzer

3-in-1 Fluorometer
Colorimeter
Turbidimeter

Parameters

Offers direct-read for Fluorescein & PTSA (Fluorometer), True Turbidity measurement (White Light/IR LED), 7 LED Wavelengths & 75+ Built-In reagent based methods. As well as unique Pyxis Lab® test methods, including: Bleach Concentration, Nitrite Dioxide, Calcium, Alkalinity, Sulfite & Non-Hazardous Zinc.

Description

A multi-parameter & multi-wavelength Fluorometer, Colorimeter & Turbidimeter specifically designed for Municipal, Environmental & Industrial water analysis. It arrives pre-calibrated & ideally suited with integrated direct read testing for Fluorescein & PTSA. The SP-910 provides more accurate test results & a military-grade design for harsh field environments.

Features

- Direct Read Fluorescein & PTSA
- True Turbidity - White Light / IR LED
- 7 LED Wavelengths
- 75+ Built-In Reagent Based Methods
- Add User Defined Methods via uPyxis®
- Displays a Concentration-Time Profile Curve
- Operates with Pyxis Lab® or Industry Standard Liquid/Solid Reagents
- USEPA Compliant Methodology



EM-400 Algae Meter

Parameters

Chlorophyll-a

Description

Measures in-vivo Chlorophyll-a (ppb) concentration in water!

Features

- 0.3–100ppb Chlorophyll-a Range
- Direct Pour Sample Cell
- Instant Reagent-less Results
- Compensates for Color & Turbidity
- CHLORO-20 Synthetic Cal Standard
- Large Color Display Screen
- Sample LOCK-IN Capability
- Bluetooth® & Data Logging Capable



HM-900 OIW Analyzer

Description

A handheld fluorometer that measures concentrations of oil in water, utilizing multiple LED sources and wavelengths. This handheld offers 24mm vial direct-read oil in water measurement for Aromatic Hydrocarbons as well as Hexane Extraction and proprietary NON-TOXIC/FLAMMABLE Solvent 16mm vial method. The HM-900 contains pre-programmed curves for Marine Oil, Diesel/Kerosene & Heavy Fuel Oil.

Features

- 0.1–1,000ppm Range
- Wireless Data Upload & Calibration
- Hexane & Pyxis® Extraction Methods
- Pre-Loaded & Customizable Curves
- Uses both 24mm & 16mm Vials
- 365/470nm & 470/650nm
- Integrated Data Logging

OXIPOCKET

Handheld Devices for Water Treatment



SP-200 OXIPOCKET™ Colorimeter

Parameters

DPD - Free & Total Chlorine, Bromine, Hydrogen Peroxide, Ozone, Monochloramine, Peroxyacetic Acid (PAA), Chlorine Dioxide Wet Chemistry Methods. Proprietary Pyxis Lab® Direct Read Methods for Bleach Concentration & Chlorine Dioxide.

Description

A unique all-in-one Pocket Colorimeter specifically designed for the measurement of all primary oxidizing biocides & disinfectants commonly used in the Municipal, Domestic & Industrial marketplaces. The SP-200 OXIPOCKET™ offers colorimetric testing of oxidizing biocides & disinfectants using both Pyxis Lab® and conventional reagents. This handheld replaces the need for independent analyte colorimeters or expensive multi-component colorimeters.

Features

- Testing of Common Biocides & Disinfectants
- 3 Unique Pyxis Lab® Test Methods
- Test Timers with Live Graphical Display
- Meets EPA 334.0 Guidelines
- Large Color Display Screen
- Operates with Pyxis Lab® or Industry Standard Liquid/Solid Reagents
- DPD Secondary Verification Liquid Standards available for EPA Regulated Applications



SP-210 Bleach Handheld Meter

Parameters

Measures for Bleach Concentration as mass/mass (0-16%) while simultaneously compensating & measuring for Temperature (°F & °C).

Description

The SP-210 handheld Bleach Analyzer is uniquely designed pocket analyzer specifically designed to measure the real-time mass/mass concentration of both manufactured concentrate and diluted electrolysis produced Sodium Hypochlorite by percentage as Chlorine (Cl₂). The SP-210 offers a direct pour sample method where bleach is applied directly to the sample measurement cell of the unit. The unit is integrated with algorithm compensation for ambient light and does not require the sample to be shielded during measurement. The SP-210 works by measuring the optical density of the bleach solution using a LED based UV light source.

Features

- Simple Pour-In Sample Design – Not Affected by Ambient Light, No Sample Vials Needed!
- Sample Cell Compatible with Concentrated Liquid Bleach Solutions
- Integrated Cleanliness Diagnostics
- %Cl₂ Concentration Displayed as Mass/Mass with Auto-Resolution for Wide Range of Solutions
- Sample Temperature & Internal RTU Temperature Compensation of Bleach Concentration



SP-208 OXIGO Pocket Chlorine Colorimeter

Parameters

Measures for Free & Total Chlorine ONLY at low (0–2.2ppm) and high (0.2–10ppm) ranges.

Description

The SP-208 OXIGO CHLORINE is a unique pocket chlorine colorimeter that measures for Free & Total Chlorine only. Specifically designed for those who desire to monitor for chlorine in the field. The SP-208 OXIGO Chlorine Colorimeter offers colorimetric testing for these oxidizing biocides with a simple user interface for rapid measurement. The SP-208 Chlorine Colorimeter reads in both high and low concentration ranges. The OXIGO Pocket Colorimeter utilizes Pyxis Lab, as well as conventional powder pillow reagents (like HACH® or Lovibond®).

Features

- *Live Graphical Display of Residual with Built-In Test Timer*
- *Utilizes both Pyxis Lab and other Industry Known DPD Powder Pillow Reagents*
- *Simple to Use Interface*
- *10mL Sample Vial Tests*
- *Military-Grade Design for In-Field Use*



EZ-10 pH Pen

Description

The EZ-10 is a simple pH pen that measures the pH & temperature of water/liquid (0–14; 0–60 °C). Powered by (3) 1.5VLR44 button batteries and offering a live display, this simple pH pen will provide accurate pH measurements within seconds! The simplicity of the unit offers low maintenance and rapid results making it perfect for the education and pool sectors of the water world! One press of the power button and you are ready to rock.

Features

- 0–14pH
- 0–60 °C
- Live Digital Display
- Pocket-Sized Pen Build
- Battery-Powered
- Protective Covering for Pen



EZ-20 Conductivity Pen

Description

The EZ-20 is a simple Conductivity pen that measures the pH & temperature of water/liquid (0–2,000 μ S/cm; 0–60 °C). Powered by (3) 1.5VLR44 button batteries and offering a live display, this easy-to-use Conductivity pen will provide accurate μ S/cm measurements within seconds! The simplicity of the unit offers low maintenance and rapid results making it perfect for the education and pool sectors of the water world! One press of the power button and you are ready to rock.

Features

- 0–2,000 μ S/cm
- 0–60 °C
- Live Digital Display
- Pocket-Sized Pen Build
- Battery-Powered
- Protective Covering for Pen

Porta ✓**EZ-100 pH Meter****Description**

The EZ-100 Porta-Check is a portable pH meter that is not only suitable for sampling & measuring the pH value of aqueous solution & measures electrode potential (mV) value in laboratories but also especially suitable for pH measurement in field and mobile environment.

Features

- 0–14pH
- -1999–1999mV
- 5–110 °C (23–230 °F), ± 0.02 °
- Battery Powered - Long Life Span
- IP-65 Waterproof
- 6in High Resolution Display
- 2-Point Calibration

Perma ✓**EZ-101 pH Meter****Description**

The EZ-101 PermaCheck™ pH meter is a laboratory pH measuring instrument, which can be widely used in universities, environmental protection, medicine, food, health, geological prospecting, metallurgy, marine exploration and other fields, common acid rain detection, industrial wastewater, surface water, drinking Water, beverages, daily chemical products, textiles, etc. All these fields require pH measurement.

Features

- 0–14pH
- -1999–1999mV
- 5–110 °C (23–230 °F), ± 0.02 °
- Battery Powered - Long Life Span
- IP-65 Waterproof
- 6in High Resolution Display
- 2-Point Calibration

INLINE SENSORS

Choose from a variety of Inline Fluorometers, Turbidimeters, Industrial & Precision Sensors that offer fully integrated analog (4–20mA) & digital (RS-485 Modbus) outputs. Every Pyxis Lab[®] smart sensor contains sophisticated process control technology with integrated diagnostics. Ensure superior sensor calibration & eliminate wasted time in the field by using our Bluetooth[®] connectivity with the uPyxis[®] app.

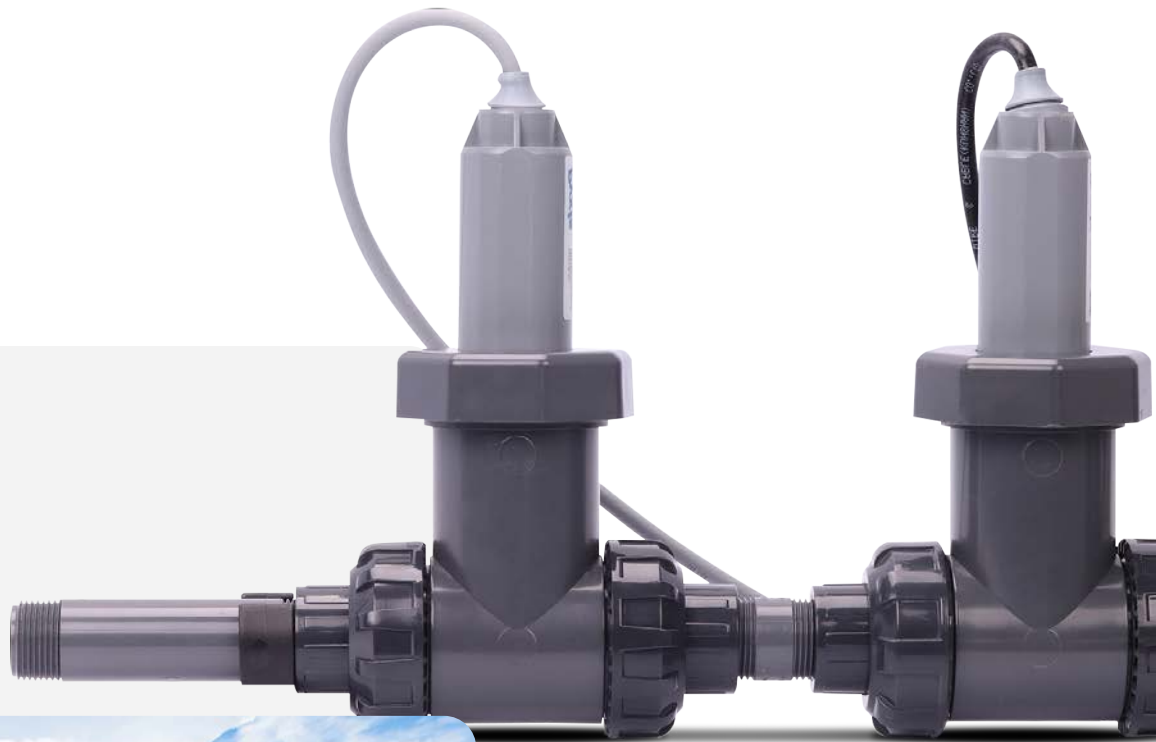

The following sensors are specifically designed to simplify installation, calibration & in-use operation in process water, industrial water, wastewater and cooling water applications. These sensors with added features dramatically improve application possibilities allowing the ST-710 Series to be directly connected to most OEM micro-processor based controller, PLC or Distributed Control Systems.



ST-710 pH Sensor

Parameters

pH



Features

- 0-14 pH Range ± 0.01 pH Unit Precision
- Automatic Temperature Compensation
- Wireless Calibration via uPyxis®
- Utilize 4-20mA or RS-485 Modbus Formats
- Long Sensor Life with 4x KCl Gel Content
- Minimal Maintenance with Enlarged Salt Bridge



ST-711 ORP Sensor

Parameters

ORP



Features

- $\pm 1,500$ mV Range with ± 1.0 mV Precision
- Wireless Calibration via uPyxis®
- Utilize 4-20mA or RS-485 Modbus Formats
- Long Sensor Life
- Minimal Maintenance with Enlarged Platinum Disk



ST-712 pH + ORP Sensor

Parameters

pH + ORP



Features

- 0-14 pH Range ± 0.01 pH Unit Precision
- $\pm 1,500$ mV Range with ± 1.0 mV Precision
- Wireless Calibration via uPyxis®
- Utilize 4-20mA or RS-485 Modbus Formats
- Long Sensor Life with 4x KCl Gel Content
- Minimal Maintenance with Enlarged Salt Bridge + ORP Disk



ST-720 Conductivity Sensor

Parameters

Conductivity + Temperature



Features

- Large/Dynamic Range 1–100,000 μ S/cm \pm 10 μ S/cm or 1.5%
- Auto Temperature Compensation at Normal Value = 25° C
- Wireless Diagnostics & Calibration via uPyxis®
- Cell Constant - K Factor = 0.3
- Dual 4-20mA or RS-485 Modbus Formats
- 4 Graphite Flat Surface Electrode Design



ST-726 Conductivity Sensor

Parameters

Conductivity + Temperature



Features

- Large/Dynamic Range 10–300,000 μ S/cm \pm 10 μ S/cm or 1.5%
- Auto Temperature Compensation at Normal Value = 25° C
- Wireless Diagnostics & Calibration via uPyxis®
- Cell Constant - K Factor = 0.3
- Dual 4-20mA or RS-485 Modbus Formats
- 4 Graphite Flat Surface Electrode Design



ST-723 High Temp Conductivity

Description

A uniquely designed high temperature conductivity + temperature sensor, ideal for boiler & process water applications. The sensor electrode is constructed of Hastelloy & PEEK with integrated cooling fins & 316LSS sensor body. Dual 4-20mA & RS-485 output. Wireless uPyxis® features.

Features

- 0–20,000 μ S/cm Conductivity Range / 5–200 °C Temp Range

Uniquely designed industrial-grade inline conductivity sensors launched by Pyxis Lab® Inc. that adopt the latest sensing technology with greatly improved detection range, accuracy and stability with anti-interference capabilities designed for use in complex environments. These sensors contain an embedded Pt-100 RTD temperature sensor allowing for auto-temperature compensation. The unique flat surface also makes sensor cleaning & calibration very easy.

Ultra-Low Conductivity Sensors

Our industrial grade inline ultra-low conductivity & temperature sensors are specifically designed for pure water, ultra-pure water and deionized water including Boiler Feed-water and Condensate, RO and EDI/EDR Process Water, Ion Exchange, Distillation, Semi-Conductor Cleaning, De-Gasifier Effluent Conductivity and other process applications. These are 'smart sensors' with a built-in transmitter supporting digital (RS-485 Modbus) and analog (4–20mA) signal outputs and are designed to simplify field installation, calibration and operation. The sensors have built-in RTD for the automatic compensation of sample temperature.



ST-724 Ultra-Low Conductivity

Range

0.02–1,000.0µS/cm + 0–100 °C

Features

- 4–20mA & RS-485 Outputs for Conductivity & Temperature
- Calibration & Diagnostics via uPyxis® (with MA-CR)
- Rugged Stainless Steel & Hastelloy Construction
- Ultra-Low Conductivity Detection (Resistivity = 50MΩ-0.001MΩ)
- 3/4inch NPT Threaded Installation into Standard NPT Tee



ST-725 Ultra-Low Conductivity

Range

0.02–200.0µS/cm + 0–100 °C



Features

- 4–20mA & RS-485 Outputs for Conductivity & Temperature
- Calibration & Diagnostics via uPyxis® (with MA-CR)
- Rugged Stainless Steel & Hastelloy Construction
- Ultra-Low Conductivity Detection (Resistivity = 50MΩ-0.005MΩ)
- 3/4inch NPT Threaded Installation into Standard NPT Tee



ST-728 Ultra-Low Conductivity

Range

0.02–10.0µS/cm + 0–100 °C



Features

- 4–20mA & RS-485 Outputs for Conductivity & Temperature
- Calibration & Diagnostics via uPyxis® (with MA-CR)
- Rugged Stainless Steel & Hastelloy Construction
- Ultra-Low Conductivity Detection (Resistivity = 50MΩ-0.1MΩ)
- 3/4inch NPT Threaded Installation into Standard NPT Tee



ST-730 Turbidimeter

Range

0–100 NTU

Accuracy

±2%

Resolution

0.1 NTU



ST-730B Turbidimeter

Range

0–1,000 NTU

Accuracy

±2%

Resolution

1 NTU



ST-731 Turbidimeter

Range

0–10 NTU

Accuracy

±2%

Resolution

0.05 NTU



ST-735 Turbidimeter

Range

0–10,000 NTU

Accuracy

±2%

Resolution

10 NTU



Features

- 90° Scattering - White Light/860nm LED
- Reliable & Accurate Readings
- Industrial & Compact Probe Design
- Includes ST-001 Tee Assembly
- Isolated 4-20mA & RS-485 Modbus Outputs
- uPyxis® Features with MA-WB Adapter
- Diagnostics & Calibration via uPyxis®
- Beaker Calibrated in Ambient Light using Formazin Turbidity Calibration Standards



LT-73X Ultra-Low Turbidity Sensors

The LT-73X Series of Ultra-Low Turbidity Sensors meet EPA-180.1 compliance guidelines by utilizing Warm White Light (LED) with a flat surface distal end in a quartz glass plate, allowing for extended cleanliness, easy maintenance and prevention of air bubble interference. The LT-73X Series offers a resolution (repeatability) of 0.001NTU & accuracy of ± 0.005 NTU, when used with the FR-100 Flow Reservoir for Drinking Water Applications. For small footprint installations, the LT-73X Series may be installed in the FT-100 Inline Flow Tee. These sensors are wirelessly calibrated with the uPyxis® app using either liquid formazin or Pyxis Lab® LT-SOLID-CAL Solid State Calibration Kits.



LT-736 Ultra-Low Turbidity

Range

0.002–1,000NTU

Resolution

0.001NTU



LT-737 Ultra-Low Turbidity

Range

0.001–5.0NTU

Resolution

0.001NTU



LT-739 Ultra-Low Turbidity

Range

0.001–40.00NTU

Resolution

0.001NTU





LT-73XB Ultra-Low Turbidity Sensors

The LT-73XB Series of Ultra-Low Turbidity Sensors meet ISO-7027 compliance guidelines by utilizing Infra Red LED (860nm) with a flat surface distal end in a quartz glass plate, allowing for extended cleanliness, easy maintenance and prevention of air bubble interference. The LT-73XB Series offers a resolution (repeatability) of 0.001NTU & accuracy of ± 0.005 NTU, when used with the FR-100 Flow Reservoir for Drinking Water Applications. For small footprint installations, the LT-73X Series may be installed in the FT-100 Inline Flow Tee. These sensors are wirelessly calibrated with the uPyxis® app using either liquid formazin or Pyxis Lab® LT-SOLID-CAL Solid State Calibration Kits.



LT-736B Ultra-Low Turbidity

Range

0.002–1,000NTU

Resolution

0.001NTU



LT-737B Ultra-Low Turbidity

Range

0.001–5.0NTU

Resolution

0.001NTU



LT-739B Ultra-Low Turbidity

Range

0.001–40.00NTU

Resolution

0.001NTU



Thanks to the state-of-the-art fluorescence technology adopted in our design, the ST-500 series are very forgiving to real world sample water conditions. With its flow-through optical design and multiple wavelength color/turbidity compensation algorithm, the ST-500 probe keeps high performance for water samples with up to 100 NTU turbidity and/or 5ppm iron. Previously run experiments & continuous studies clearly demonstrate the superior performance of the Pyxis Lab® ST-500 probe in the presence of iron color.



ST-500 PTSA Sensor

Parameters

PTSA (0–300ppb) for Cooling & Process Water



Description

A proprietary design, the ST-500 measures for the concentration of PTSA Fluorescent Tracer (0-300ppb), automatically compensating for Color (10ppm as Iron) & Turbidity (<150NTU). Offers integrated 4-20mA + RS-485 outputs and may be diagnosed for cleanliness/calibrated via uPyxis®.



ST-500RO PTSA Sensor

Parameters

PTSA (0–40ppb) for RO Feed-water



Description

The ST-500RO measures for the concentration of PTSA Fluorescent Tracer (0-40ppb), automatically compensating for Color (10ppm as Iron) & Turbidity (<150NTU). Offers integrated 4-20mA + RS-485 outputs and may be diagnosed for cleanliness/calibrated via uPyxis® with the MA-WB adapter.



NEW

ST-587 PTSA + Turbidity Sensor

Parameters

PTSA (0–500ppb) Expanded Range
Turbidity (0–200NTU)

Description

The ST-587 measures for the concentration of PTSA Fluorescent Tracer (0-500ppb) and Turbidity (0–200NTU). Offers integrated 4-20mA + RS-485 outputs and may be diagnosed for cleanliness/calibrated via uPyxis® with the MA-WB adapter.

HM-500 Series OIW Sensors

Parameters

Oil Content in Water 0–10ppm / 0–100ppm / 0–1,000ppm

Description

The HM-500 series inline fluorometer sensors measure the concentration of oil in water read as ppm Marine Crude-Offshore Oil. The sensors utilize an LED sourced UV-fluorescence methodology at 365nm wavelength and 410/470nm excitation. The HM-500 series sensors are uniquely designed with extra photo-electric components that also monitor the color and turbidity of the sample water.

Ask about our Oil In Water Clean-In-Place Panel!



ST-525 Fluorescein Sensor

Parameters

Fluorescein (0–60ppb) for Traced Industrial Process

Description

The ST-525 offers a proprietary design for Fluorescein measurement (Fluorescein Sodium Salt/Uranine, CAS# 508-47-8) utilizing LED light sources. Offers integrated 4-20mA + RS-485 outputs & may be diagnosed for cleanliness/calibrated via uPyxis® with the MA-WB adapter.



ST-525HR Fluorescein Sensor

Parameters

Fluorescein (0–500ppb) for Traced Industrial Water Process

Description

The ST-525HR offers a proprietary design for Fluorescein measurement (Fluorescein Sodium Salt/Uranine, CAS# 508-47-8) utilizing LED light sources. Offers integrated 4-20mA + RS-485 outputs & may be diagnosed for cleanliness/calibrated via uPyxis® with the MA-WB adapter.



Stainless Steel ST-525 Variants

ST-525SS

Fluorescein (0–60ppb) for Traced Industrial Water Process.

ST-525SS-HR

Fluorescein (0–500ppb) for Traced Industrial Water Process



Our latest SS-T Series of inline sensors offer a new 316-stainless steel design allowing insertion and removal of the sensor into the new Pyxis ST-009 (Stainless Steel) inline tee assembly for high pressure applications up to 290psig. The sensor uses temperature-tolerant and humidity-resistant optical filters that can be operated under a wide range of ambient conditions without the need of humidity and temperature regulation. With this design the performance of these sensors can remain stable and consistent for an extended period time.



ST-500SS-T PTSA Sensor

Parameters

PTSA (0–300ppb) for Cooling & Process Water



Description

A proprietary design, the ST-500SS-T measures for the concentration of PTSA Fluorescent Tracer (0-300ppb), automatically compensating for Color (10ppm as Iron) & Turbidity (<150NTU). Offers integrated 4-20mA + RS-485 outputs and may be diagnosed for cleanliness/calibrated via uPyxis®.



ST-525SS-T Fluorescein Sensor

Parameters

Fluorescein (0–60ppb)



Description

The ST-525SS-T offers a proprietary design for Fluorescein measurement (Fluorescein Sodium Salt/Uranine, CAS# 508-47-8) utilizing LED light sources. Offers integrated 4-20mA + RS-485 outputs & may be diagnosed for cleanliness/calibrated via uPyxis®.



ST-525SS-HR-T Fluorescein Sensor

Parameters

Fluorescein High Range (0–500ppb)

Description

The ST-525SS-HR-T offers a proprietary design for Fluorescein measurement (Fluorescein Sodium Salt/Uranine, CAS# 508-47-8) utilizing LED light sources. Offers integrated 4-20mA + RS-485 outputs & may be diagnosed for cleanliness/calibrated via uPyxis®.



ST-587SS-T PTSA + Turbidity Sensor

Parameters

PTSA (0–500ppb) Expanded Range
Turbidity (0–200NTU)

Description

The ST-587SS-T measures for the concentration of PTSA Fluorescent Tracer (0-500ppb) and Turbidity (0–200NTU). Offers integrated 4-20mA + RS-485 outputs and may be diagnosed for cleanliness/calibrated via uPyxis® with the MA-WB adapter.



ST-588SS-T PTSA + Tagged Polymer

Parameters

PTSA (0–200ppb Default; 0–500ppb Capable)
Fluorescent Polymer (0–20ppm)

Description

The ST-588SS-T is a combination sensor capable of measuring PTSA in a range of 0-200ppb (0-500ppb capable) and Fluorescent Polymer on a scale of 0-20ppm, offering dual 4-20mA & RS-485 outputs.



ST-590SS-T Tagged Polymer Sensor

Parameters

Fluorescent Polymer (0–20ppm)

Description

The ST-590SS-T is an inline sensor capable of measuring Fluorescent Polymer on a scale of 0-20ppm, offering 4-20mA & RS-485 outputs & may be wirelessly diagnosed for cleanliness & calibrated via the uPyxis® app.



ST-009 Stainless Steel Assembly

Description

The ST-009 is a 316L stainless steel tee assembly for the ST-Series of inline sensors. This system offers 3/4in FNPT thread inlet/ outlet and is built for high temperature and high pressure applications.



Many companies in the water treatment industry have expressed a desire to evaluate this unique fluorescent tracer for high pressure boiler water tracing applications. The ST-540 Series are inline fluorometers designed for those desiring to conduct research and development of NDSA traced boiler or process water treatment programs. The ST-540 Series offer direct measurement of NDSA (Napthenic Disulfonic Acid CAS# 1655-29-4) utilizing LED light sources for use in boiler water and boiler feedwater measurement applications.



ST-540A NDSA Sensor

Parameters

NDSA (0–500ppb)

Description

The ST-540 Series offers Pyxis proprietary algorithms to determine the concentrations of NDSA in a range of 0-500ppb while simultaneously measuring light loss through the optical channel to determine sensor cleanliness. Connect to uPyxis® via the MA-WB Bluetooth® adapter.



ST-540SS NDSA Sensor

Parameters

NDSA (0–500ppb)

Description

The ST-540 Series offers Pyxis proprietary algorithms to determine the concentrations of NDSA in a range of 0-500ppb while simultaneously measuring light loss through the optical channel to determine sensor cleanliness. Connect to uPyxis® via the MA-WB Bluetooth® adapter.



ST-540SS-N NDSA Sensor

Parameters

NDSA (0–20ppb)

Description

The ST-540 Series offers Pyxis proprietary algorithms to determine the concentrations of NDSA in a range of 0-500ppb while simultaneously measuring light loss through the optical channel to determine sensor cleanliness. Connect to uPyxis® via the MA-WB Bluetooth® adapter.

LT-63X Self-Wiping Turbidity Sensor Series

Parameters

LT-631 Turbidity (0–500NTU)

LT-632 Turbidity (0–1,000NTU) for Raw Water & Wastewater Effluent

LT-633 Turbidity (0–4,000NTU) for Raw Water & Wastewater Effluent

Description

The LT-63X series sensor platform (including the LT-631, LT-632 and LT-633) are submersible, waterproof, self-cleaning sensors utilize dual wavelength detection technology to measure turbidity in the ranges of 0 to 4000 NTU. The sensor automatically compensates for disturbances caused by flow fluctuations, climate change, color change or changes in turbidity. The instrument design is virtually maintenance-free, and the self-cleaning capability of the sensor prevents deviations caused by air bubbles and suspended solids particulate. It is powered by a 24 VDC/6W power supply and offers fully integrated 4-20 mA and RS-485 Modbus output signals for connection to any controller, PLC or DCS network. When clean, the unique Pyxis sensor design offers a stability of <0.1 NTU for up to 1-year without calibration.



LT-635 Self-Wiping Suspended Solids Sensor

Parameters

Suspended Solids (0–30,000ppm) for Activated Sludge Solids & Clarifier Sludge Bed Detection

Description

The LT-635 is a submersible, waterproof, self-cleaning sensor that determines the concentration of suspended solids by measuring the attenuation of an infrared light source through the sample media. The sensor automatically compensates for disturbances caused by flow fluctuation and color of the water containing high levels of suspended solids. The instrument is virtually maintenance-free and the self-cleaning capability of the sensor prevents deviations caused by air bubbles, sessile bacteria (slime) and sludge particulate resulting in highly accurate suspended solids measurement which can directly reduce operation costs while improving efficiency and environmental compliance.



Fluorescent Polymer Inline Sensors

Compete on a world-class level!

Our line of proprietary technology offers cutting-edge optical measurement of Fluorescent Polymer. These easy-to-use handheld devices offer the ability to directly measure for Fluorescent Polymer now available on the market for use in cooling & process water treatment chemistries.

Interference Resistant Technology!

These Fluorescent (Tagged) Polymer sensors compensate for color, turbidity & PTSA overlap interference while providing sensor cleanliness diagnostics through sophisticated internal algorithms proprietary to Pyxis Lab®. This sensor technology enables water treatment companies the ability to monitor available polymer residuals for application stress indication, allowing you to compete on a world-class level.

PTAG-1010 Combined Standard

Description

A combination calibration standard solution that offers both 10ppm Fluorescent Polymer & 100ppb PTSA in a 500mL bottle. Calibrate for PTSA & Tagged Polymer with one standard.



ST-588 PTSA + Tagged Polymer

Parameters

PTSA (0–200ppb) + Fluorescent Polymer (0–20ppm)

Description

The ST-588 is an inline combination sensor capable of measuring PTSA in a range of 0-200ppb (0-500ppb capable) and Fluorescent Polymer on a scale of 0-20ppm, offering dual 4-20mA & RS-485 outputs & may be wirelessly diagnosed for cleanliness & calibrated via the uPyxis® app.



ST-590 Tagged Polymer Sensor

Parameters

Fluorescent Polymer (0-20ppm)

Description

The ST-590 is an inline sensor capable of measuring Fluorescent Polymer on a scale of 0-20ppm, offering 4-20mA & RS-485 outputs & may be wirelessly diagnosed for cleanliness & calibrated via the uPyxis® app.





Stainless Steel Variants Available:

ST-500SS	PTSA for Cooling & Process Water
ST-500ROSS	PTSA for RO Feedwater
ST-525SS	Fluorescein for Boiler & Feedwater
ST-525HR-SS	High Range Fluorescein for Boiler & Closed Loop Systems
ST-565SS	Azole
ST-588SS	PTSA + Fluorescent Polymer
ST-590SS	Fluorescent Polymer
ST-710SS	pH
ST-711SS	ORP
ST-712SS	pH + ORP
ST-730SS	Turbidity
HM-500SS Series	Oil Content in Water



Features

- 304 Stainless Steel Construction
- Upper Temperature Limit - 120° F / 49 °C
- Upper Pressure Limit - 290psi (20Bar)
- Integrated Transmitter
- 4-20mA & RS-485 Outputs
- Quick Connect 7 or 8 Pin Formats
- Bluetooth® Ready with MA-CR/WB
- Wireless Diagnostics & Calibration via uPyxis®
- Ideal for Harsh Environments
- 3/4inch FNPT Installation

Inline Disinfectant + Temp Sensors

The ST-600 Series of inline sensors measure the real-time mass/mass concentration of Chlorine content in Sodium Hypochlorite (Bleach) and Chlorine Dioxide (ClO_2) in solution. Unlike amperometric sensors used for point of application measurement (ppm), the ST-600 series directly measure the optical density of the source solution of Bleach or Chlorine Dioxide. This is measured as percent (%) for concentration determination of the produced oxidizer solution or precursor being used in the oxidizer generation process. The ST-600 series offers integrated dual 4–20mA & RS-485 outputs and may be wirelessly diagnosed for cleanliness & calibrated via the uPyxis® app when using the MA-WB adapter. These sensors are ideal for use in determining real-time concentration of chemical precursors or generated oxidizer solutions in a wide variety of applications and industries, optimizing efficiency and reducing chemical costs.



ST-600 Inline Bleach Sensor

Parameters

% Concentration of Chlorine in Bleach (0–16%)

Description

An inline sensor that measures % concentration of Chlorine in Bleach (Sodium Hypochlorite). The sensor may be installed in two formats (inline tee or Teflon tubing) depending on volume of bleach flow measured. Temperature compensated bleach concentration is provided.



ST-601 Inline ClO_2 Sensor

Parameters

% Concentration of Chlorine Dioxide in Solution (0–0.35%)

Description

An inline sensor that measures % concentration of Chlorine Dioxide (ClO_2) solution. The sensor may be installed in two formats (inline tee or Teflon tubing) depending on volume of solution being measured. Temperature compensated ClO_2 concentration is provided.



ST-606 Acidified Sodium Chlorite

Parameters

ASC (Acidified Sodium Chlorite 0–1,200ppm)

Description

An inline sensor that measures ASC (Acidified Sodium Chlorite). A blend of Sodium Chlorite and Citric Acid, ASC is commonly used in the food/beverage market for sanitation. This new sensor platform measures at a range of 0–1,200ppm.

NEW



ST-765SS Series pH + FCL, TCL, ClO₂, O₃ or SO₃ Sensors

Parameters

ST-765SS-FCL pH + Residual Chlorine (0.00–5.00ppm)

ST-765SS-CLO pH + Chlorine Dioxide (0.00–5.00ppm)

ST-765SS-TCL pH + Total Chlorine (0.00–5.00ppm)

ST-765SS-O3 pH + Ozone (0.00–2.00ppm)

ST-765SS-Br pH + Bromine (0.00–5.00ppm)

ST-765SS-DCL pH + Free Chlorine (0.00–5.00ppm) + Sulfite (0.00–100ppm)

ST-765SS-NCL pH + Monochloramine (0.0–5.00ppm)

ST-765SS-SO3 pH + Sulfite (0–100ppm)

Description

Stainless steel multi-parameter membrane-less sensors based on unique electrochemical principles to determine Oxidizer & pH content in water. These sensors incorporate advanced technology in the field of bare-gold electrochemical detection. The ST-765 Series offers real-time measurement of pH & Temperature, coupled with Residual Chlorine, Chlorine Dioxide, Ozone, Bromine, Dechlorination (F-CL + SO₃) or Sulfite sensor platform options. This unique platform offers fully integrated pH compensation in the sensor itself, eliminating the need for a separate pH sensor and controller. All variants can optionally be installed into the ST-007 tee system if desired.

Features

- Real-Time pH + Temperature Detection
- pH Compensated Residual Chlorine Value
- pH Compensated Sulfite Value
- pH Compensated Chlorine Dioxide Value
- Dual 4-20mA & RS-485 Outputs
- Wireless Diagnostics & Calibration via uPyxis®
- Integrated RTD & pH Compensation up to pH 9.0 of the Oxidizer Value
- Replaceable Reference Electrode
- USEPA-334.0 Compliant

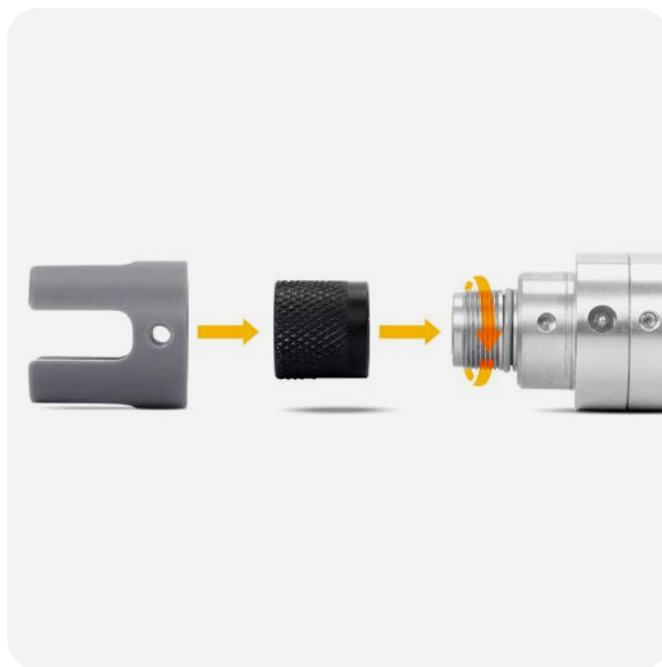

ST-772 Series Luminescent Dissolved Oxygen Sensors

Parameters

Dissolved Oxygen in Water (0.00–20.00ppm)

Temperature (0–50 °C)

Description

The ST-772 Series optical luminescent dissolved oxygen (DO) sensor is based on the principle of 'Fluorescence Quenching' to determine the dissolved oxygen content in water. It incorporates Pyxis Lab® advanced technology in the field of fluorescence detection and uses Blue/Red light detection technology with excitation and reference light sources, offering a wide range and very low detection limit. The sensors also integrate temperature and pressure detection for compensation for the final DO value. The ST-772 series offers an easily replaceable front loading DO membrane cap that has been independently developed by Pyxis Lab®, with a typical service life of two years. Both submersed and inline design versions in 316L stainless steel and CPVC are available. Integrated dual 4–20mA & RS-485 outputs with wireless diagnostics & calibration via uPyxis®. This sensor platform may be connected to any controller, PLC or DCS network.

Simple Maintenance

The ST-772 series of sensors offer easily replaceable, front loading DO cartridge (DCC-01) that has been independently developed Pyxis Lab®, with a typical service life of up to two years. This unique DO cartridge design incorporates a black micro-porous PTFE membrane material designed to provide extreme scratch resistance, extended life span and simple replacement.



ST-772 Dissolved Oxygen Sensor

Quick Features

316L Stainless Steel
Submersible Installation
30ft (10m) Bulkhead Cable Attached



ST-772P CPVC Dissolved Oxygen Sensor

Quick Features

CPVC
Submersible Installation
30ft (10m) Bulkhead Cable Attached



ST-772T Inline Dissolved Oxygen Sensor

Quick Features

316L Stainless Steel
Inline or Bypass Flow Installations
ST-001 Tee Assembly Provided



ST-772TP Inline Dissolved Oxygen Sensor

Quick Features

CPVC
Inline or Bypass Flow Installations
ST-001 Tee Assembly Provided



Features

- 0.00–20.00mg/L (ppm) Range
- 0.01mg/L Resolution
- 0.004ppm LDL (Lower Detection Limit)
- 0–200% Saturation or 0–500mBarO₂
- Temperature Output 0–50 °C
- No Membranes or Electrolyte
- Simple DO Cartridge Replacement
- RTD & Pressure Compensated Output
- Integrated Transmitter
- Dual 4–20mA & RS-485 Outputs
- Response Time <60s
- Ultra-Low Drift
- Slope Calibrated with Room Air
- Up to 2 Year Cartridge Life
- Floating or Fixed Submersion Install
- Inline Pressurized Tee Install
- 145psi (10Bar) Working Pressure
- 0–45 °C Operational Temperature
- EPA 40CFR Part 136.3 Compliant
- 316L Stainless Steel or CPVC Body
- Bluetooth® Ready with MA-CR Adapter
- Diagnostics & Calibration via uPyxis®



ST-774 Ultra-Low Luminescent Dissolved Oxygen Sensors

Parameters

Ultra-Low Dissolved Oxygen Residuals (0–2,000ppb)

Description

Measure for ultra-low residual of dissolved oxygen with this luminescent dissolved oxygen sensor. Our latest DO sensor offers a range of 0–2,000ppb with an unmatched lower detection limit of 0.1ppb. This sensor is based on the principle of 'Fluorescence Quenching' to determine the partial pressure of dissolved oxygen in water. The ST-774 offers real-time compensation via integrated temperature & pressure sensors with an easily replaceable front loading DO cartridge (DCC-02). The ST-774 arrives factory-calibrated and can be immediately deployed with no need to calibrate for up to one year. Wirelessly diagnose & zero calibrate via uPyxis® & the MA-CR adapter using pure nitrogen gas (DCC-03) or 5% catalyzed sodium sulfite. The ST-774 offers fully integrated 4–20mA & RS-485 outputs for direct connection to any controller, PLC or DCS network.



Flow Cell

The ST-774 is provided with a Pyxis Lab® proprietary stainless steel flow cell with an integrated 1/4 inch Swagelok inlet & outlet and seal. This airtight flow cell allows for simple installation and when properly installed on stainless steel compression sample line mitigates oxygen contamination in the sample stream.

Features

- 0–2,000ppb Range
- 0.1ppb Resolution
- 0.1ppb Lower Detection Limit
- No Membranes or Electrolyte
- Simple DO Cartridge Replacement
- RTD & Pressure Compensated Output
- Integrated Transmitter
- 4-20mA & RS-485 Output
- Response Time <30s
- Ultra-Low Drift
- Zero Calibrated with N Gas or Sulfite
- Up to 2 Year Cartridge Life
- Unique 316L Swagelok Flow Cell
- 145psi (10Bar) Working Pressure
- 0–50 °C Operational Temperature
- 316L Stainless Steel Body
- Bluetooth® Ready with MA-CR Adapter
- Diagnostics & Calibration via uPyxis®



Introducing the PortaPanel™

Parameters

Ultra-Low Dissolved Oxygen Residuals (0–2,000ppb)

Description

A pre-fabricated panel ideally suited for those desiring to use the ST-774 ultra-low DO Sensor with local display & data acquisition in a portable fashion.

Flip to the Panels Section to Learn More...



PRISM

Inline Sensors for Water Treatment



RT-100 PRISM™ Inline Refractometer

Parameters

- Refractive Index Value (1.30000–1.5100)
- BRIX (0.00–85.00%)
- Mono-Ethylene Glycol (0.00–100.00%)
- Mono-Propylene Glycol (0.00–100.00%)
- Advanced Low Viscosity Fluid (0.00–100.00%)
- Temperature (-20–80 °C)

Description

An inline digital refractometer that measures the refractive index of a liquid sample and provides a direct reading of highly accurate concentration values for wide variety of water and process related applications. The PRISM™ is a stand alone device capable of self-sustained operation, live data display and data logging. The RT-100 PRISM™ also fully integrated 4-20mA and RS-485 Modbus output signals for connectivity to any microprocessor-based controller, display, PLC or DCS network. The PRISM™ has built-in temperature dependent equations to convert the measured sample temperature and refractive index to the percentage concentration of Mono-Ethylene Glycol (MEG), Mono-Propylene Glycol (MPG), Sugar Content (BRIX) and Advanced Low Viscosity Fluid (ALV).

The PRISM™ is a robust, digital sensor and is capable of operating in contaminated fluid samples. It is important to note that users should take precautions to mitigate & filter suspended solids from the sample stream prior to the sensor to avoid tenacious deposit build-up on the sensor eye. In highly fouled applications, Pyxis Lab® recommends users conduct sensor eye cleaning on a regular basis.





RT-200 PRISM™ High Pressure/Temperature Inline Refractometer

Parameters

Refractive Index Value (1.30000–1.5100)
 BRIX (0.00–85.00%)
 Mono-Ethylene Glycol (0.00–100.00%)
 Mono-Propylene Glycol (0.00–100.00%)
 Advanced Low Viscosity Fluid (0.00–100.00%)
 Temperature (-20–80 °C)

Description

The Pyxis RT-200 Prism is an inline digital refractometer that measures the refractive index of a liquid sample and provides a direct reading of highly accurate concentration values for a wide variety of water and process related applications. RT-200 is particularly suitable for sugar production and other high-temperature processes. It is a stand-alone device capable of self-sustained operation, live data display and data logging.

The RT-200 Prism also offers fully integrated 4-20mA and RS-485 Modbus output signals for connectivity to any microprocessor-based controller, display, PLC or DCS network. The RT-200 Prism has built-in temperature dependent equations to convert the measured sample temperature and refractive index to the percentage concentration of Mono Ethylene Glycol (MEG), Mono Propylene Glycol (MPG), Sugar Content (Brix) and Advanced Low Viscosity Fluid (ALV). Built-in Bluetooth 5.0 makes it easier to connect to your phone. Additional concentration curves can be added via uPyxis APP.

Sample Temperature: -4-248 °F (-20-120 °C)

PRISM

Inline Sensors for Water Treatment



RT-50 PRISM™ Refractive Index & BRIX Sensor for Cutting Fluid

Parameters

Refractive Index Value (1.3200–1.400)

BRIX (0.00–38.00%)

Temperature (-20–80 °C)



Description

The Pyxis RT-50 Prism is an inline digital refractometer that measures the refractive index of a liquid sample and provides a direct reading of highly accurate concentration values for a wide variety of process applications including cutting fluid concentration detection. It is a stand-alone device capable of self-sustained operation, live data display and data logging. The RT-50 Prism also offers fully integrated 4-20mA and RS-485 Modbus output signals for connectivity to any microprocessor-based controller, display, PLC or DCS network.

The RT-50 Prism has built-in temperature dependent equations to convert the measured sample temperature and refractive index to the BRIX concentration. User defined concentration curves and output may also be programmed to the RT-50 through the uPyxis APP interface through user entry of know formula coefficient values. This enables the RT-50 to provide a user-customized display and output of the concentration of the material being measured, as desired.

Create Custom Curves to fit Your Application!



Inline Sensors for Water Treatment

Features

- 4-20mA Output of Sample Temperature & the Unit of Display Selected via Screen Interface
- RS-485 RTU Output for Temperature, Refractive Index & other Diagnosis Parameters
- Built-In Temperature Dependent Equations %BRX, %MEG, %MPG & %ALV
- Future Addition of Product Concentration Curves by Pyxis Lab® as Market Requests
- Local Display & Push Button Interface
- Optional 110VAC-24V DC Wall Outlet Powered for Independent Operation with no Controller
- Built-In Historical Data Log up to 56 Days of Storage at 1 Reading per minute via uPyxis®
- Bluetooth® Enabled when used with the MA-CR Bluetooth® Adapter
- Sturdy 316L Stainless Steel Construction & Suitable for Harsh Application Environments
- Convenient Stainless Steel Tri-Clamp Flow Cell Assembly with 3/4 inch NPT Flange
- Easy Installation & Removal for Cleaning & Maintenance - No Tools Required



RT-Series Ultrasonic Cleaning Transducer

Features

- Accessory for Automatic Cleaning of RT-100
- Comes as a kit with Control Box, Module & Cables
- Ultrasonic Transducer Mounts into the Tri-Clamp Assembly
- Control Box Powers Transducer & RT-100 Sensor
- Control Box take Cleaning Signal from RT-100 for Activation
- Cleaning Cycle is Programmable for 5, 15 or 30 Minute Cycles



CORROSION SENSORS

Ideal for Cooling & Process water treatment, the Pyxis Lab[®] CR-Series of Corrosion Rate Sensors utilize Linear Polarization Resistance (LPR) technology to provide real-time general corrosion (MPY) & Localized Corrosion Index. Instantaneous corrosion rate monitoring & data acquisition can be achieved for a wide variety of preprogrammed globally recognized metallurgies or customized metallurgies through wireless configuration via uPyxis[®].





CR-200 Wireless LPR Sensor

Parameters

LPR General & Localized Corrosion Rate

Description

A lithium battery-powered & Bluetooth® enabled corrosion sensor for portable use, internal data logging & wireless data transfer. The CR-200 makes it possible to monitor corrosion at multiple test points, avoiding the complications of running power and signal output wires from the sensor to the controller. The CR-200 can store up to 6 months of corrosion data wirelessly transferable via uPyxis® as a .CSV file.

Features

- Anti-Electromagnetic Interference Design
- Battery Life up to 1 Year
- Bluetooth® Ready for uPyxis® Features
- Measure General & Localized Corrosion
- Conductivity Compensated (10,000 μ S/cm)
- Ultra-Low Corrosion Detection of 0.001MPY
- 20+ Preprogrammed Metallurgy Options



CR-300 Wired LPR Sensor

Parameters

LPR General & Localized Corrosion Rate

Description

A 24V DC powered LPR corrosion sensor for wired connectivity to a controller, PLC or DCS network. The CR-300 offers integrated 4-20mA & RS-485 outputs and wireless connectivity when used with the MA-CR adapter for configuration on uPyxis®. The CR-300 provides instantaneous General & Localized corrosion output signals to the receiving device.

Features

- Anti-Electromagnetic Interference Design
- Dual 4-20mA & RS-485 Outputs
- Bluetooth® Ready for uPyxis® w/ MA-CR
- Measure General & Localized Corrosion
- Conductivity Compensated (10,000 μ S/cm)
- Ultra-Low Corrosion Detection of 0.001MPY
- 20+ Preprogrammed Metallurgy Options



CR-301 High Temperature & Pressure LPR Corrosion

Parameters

LPR General & Localized Corrosion Rate

Description

Developed specifically for use in high temperature and high pressure applications, the CR-301 LPR corrosion rate sensor is ideal for harsh conditions in process application monitoring where robustness & affordability are essential. The sensor utilizes Linear Polarization Resistance (LPR) technology to provide instantaneous general & localized corrosion rate.

The CR-301 offers integrated dual 4-20mA & RS-485 outputs and wireless connectivity when used with the MA-CR adapter for configuration on uPyxis®. The CR-301 measures and compensates for conductivity impact on LPR measurement.

Features

- -10–240 °C (14–460 °F) Operational Temp
- <500psi (34.5Bar) Operational Pressure
- Titanium & PEEK Liquid End
- 316L Stainless Steel Body
- Anti-Electromagnetic Interferences
- Conductivity Compensation (50,000µS/cm)
- Ultra-Low Detection of 0.001MPY
- 20+ Preprogrammed Metallurgy Options
- Bluetooth® Ready with the MA-CR
- Dual 4-20mA & RS-485 Outputs

LEVEL SENSORS

Pyxis Lab[®] offers a wide variety of Ultrasonic & Pressure Transducer Level Sensors for precise measurement of liquid volume & liquid column height. The Pyxis Lab[®] level sensor platform integrates 4-20mA & RS-485 Modbus output as well as Bluetooth[®] connectivity for wireless configuration and data acquisition.





LS-200 Ultrasonic Level Sensor

Description

A general purpose and innovative liquid level sensor that provides continuous level measurement up to 106 inches (2.7m) with integrated 4–20mA & RS-485 outputs. The LS-200 also offers integrated Bluetooth® 5.0 and can be wirelessly configured using uPyxis®. This capability enables the user to rapidly install, configure and deploy the LS-200 level sensor with no external equipment or minimum liquid level necessary.

The LS-200 level sensor is powered by a 24V DC (2W) external power source and comes equipped with a 3m (10ft) waterproof 7-Pin quick adapter/flying lead output cable. Extension cables are available for long distance installations. This non-contact ultrasonic liquid level sensor is ideally suited for corrosive liquid, chemical or process tank applications.

Features

- 1inch MNPT Threaded Installation
- Electromagnetic Interference Compensation
- Embedded 4-20mA & RS-485 Transmitter
- Bluetooth® 5.0 for Wireless Configuration
- 24V DC with Smart Switch Capability
- PVDF Transducer/6P Polycarbonate Enclosure
- Waterproof Adapter Cable
- IP-67
- CE / RoHS Certified



LS-202 Ultrasonic Level Sensor

Description

A general purpose AA-Standard battery or 24V DC powered liquid level sensor with local display that provides continuous level measurement up to 106 inches (2.7m) with integrated 4-20mA & RS-485 outputs. The LS-202 also offers integrated Bluetooth® 5.0 and can be wirelessly configured using the uPyxis® app. This capability enables the user to rapidly install, configure, store and wirelessly transfer liquid level data as a .CSV file via email. The LS-202 level sensor comes equipped with a 3m (10ft) waterproof 7-Pin quick adapter/flying lead output cable. Extension cables are available for long distance wired installations. This non-contact ultrasonic liquid level sensor offers the user flexibility of stand-alone installation when operated in 'Battery Mode' eliminating the costs associated with conventionally powered level sensors. Explosion-proof version is also available (LS-202EX).

Features

- 1.3" Display & 4-Push Button Navigation
- AA Battery or 24V DC Power Supply
- Battery Life up to 9 Months
- Stores up to 6 Months of Inventory Data
- Bluetooth® 5.0 for Wireless Configuration
- 1" MNPT Threaded Installation
- Electromagnetic Interference Compensation
- Embedded 4-20mA & RS-485 Outputs
- PVDF Transducer/6P Polycarbonate Enclosure
- IP-67 / CE & RoHS Certified

LSP-X01 Submersible Level Sensors

Description

The Pyxis Lab® LSP-X01 series are pressure transducer, submersible level sensors offered in 316L stainless steel (LSP-101), PVC (LSP-201) and PVDF (LSP-301) formats for a variety of liquid level applications in a range of 0–10m (32.8ft) as H₂O.

The LSP-X01 series of pressure transducer level sensors require 24V DC (2W) power supply and incorporate a fully-embedded 4–20mA transmitter for wired connection to any controller, PLC or DCS network. This platform offers integrated Bluetooth® 5.0 and can be wirelessly configured using the uPyxis® app by easily entering the measured liquid specific gravity and known tank volume. The LSP-X01 series are provided with an attached PTFE transducer cable for drop-in installation. The sensor enclosure offers a 1inch MNPT threaded installation and includes a 3m (10ft) waterproof 7-Pin quick adapter/flying lead output cable. Extension cables are available for long distance installations.



LSP-101 Pressure Transducer Level Sensor

Material & Submersion Depth

316L Stainless Steel
10m (32.8ft)



LSP-201 Pressure Transducer Level Sensor

Material & Submersion Depth

PVC
10m (32.8ft)



LSP-301 Pressure Transducer Level Sensor

Material & Submersion Depth

PVDF
10m (32.8ft)



LSP-X00 Submersible Level Sensors

Description

The Pyxis Lab® LSP-X00 series are pressure transducer, submersible level sensors offered in 316L stainless steel (LSP-100), PVC (LSP-200) and PVDF (LSP-300) formats for a variety of liquid level applications. This platform offers a level measurement range of 0–10m (32.8ft) as H₂O with a 1.3" OLED local display and integrated 4-20mA & RS-485 outputs. The LSP-X00 series can be powered by (4) AA Li/SOCl₂ batteries or 24V DC wire-power depending on user preference. When used in 'Battery Mode' the LSP-X00 series can log and store up to 6 months of inventory data. The LSP-X00 series offers integrated Bluetooth® 5.0 and can be wirelessly configured using the uPyxis® app. This capability enables the user to rapidly install, configure, store and wirelessly transfer liquid level data as a .CSV file via email. The LSP-X00 series come equipped with a 3m (10ft) waterproof 7-Pin quick adapter/flying lead output cable. Extension cables are available for long distance wired installations. The LSP-Series wall mounting bracket is also available for easy display access & visibility.



LSP-100 Pressure Transducer Level Sensor

Material & Submersion Depth

316L Stainless Steel
10m (32.8ft)



LSP-200 Pressure Transducer Level Sensor

Material & Submersion Depth

PVC
10m (32.8ft)



LSP-300 Pressure Transducer Level Sensor

Material & Submersion Depth

PVDF
10m (32.8ft)





LSR-801 Radar Level Sensor

Description

The LSR-801 sensor is a W-band FMCW continuous frequency modulation radar level transmitters. They provide continuous level measurement up to 591 inches (49.2 ft. or 15m) with 4-20 mA output as well as RS485, BlueTooth 5.0®.

The LSR-801 Series can be wirelessly configured via the uPyxis® app for Mobile or Desktop devices. This enables rapid integration and deployment in the field. The sensors are powered by a 24 VDC external power supply. This makes them ideal commonly used OEM controllers, PLC or DCS systems. This non-contact liquid level sensor platform is well suited for corrosive liquids. As well as industrial, municipal, process liquid storage and chemical feed applications.

Features

- Radar Liquid Level Measurement up to 15m
- Embedded Transmitters 4-20mA/RS-485
- Bluetooth® 5.0 for Mobile Configuration
- 24VDC Power with Smart Switch Capability
- PVDF Transducer / 6P Polycarbonate Enclosure



LSR-803 Radar Level Sensor

Description

The LSR-803 sensor are W-band FMCW continuous frequency modulation radar level transmitter. The sensor provides continuous level measurement up to 591 inches (49.2ft. or 15 m) with 4-20mA output as well as RS-485 and Bluetooth® 5.0.

The LSR-803 Series has a 1.3"OLED display and 4 buttons for quick configuration and can be wirelessly configured via the uPyxis® app for Mobile or Desktop devices enabling rapid integration and deployment in the field. The sensors are powered by a 24 VDC / 2.0W external power supply or 4-AA alkaline batteries and are ideal for use with commonly used OEM controllers, PLC or DCS systems. This non-contact liquid level sensor platform is well suited for corrosive liquids. Some usual applications include industrial, municipal process liquid storage and chemical feed applications.

Features

- Radar Liquid Level Measurement up to 15m
- Embedded Transmitters 4-20mA/RS-485
- Bluetooth® 5.0 for Mobile Configuration
- 24VDC Power with Smart Switch Capability
- PVDF Transducer / 6P Polycarbonate Enclosure

Introducing LoRa Capability!

Pyxis LoRa is a communication method that enables wireless data transmission from the level sensor via Long Range Radio signal to distances as far as 1.8km. The LSR-series may be used in conjunction with our LG-100 receiver and converter that allows users to capture or 'catch' the LoRa signal from the level sensor and convert the received data into one 4-20mA output or up to 4 RS-485 Modbus outputs for direct wired connection to any remotely located controller, PLC, Gateway or DCS system. Both the LSR Series level sensors and LG Series LoRa receivers can quickly and easily be configured via the integrated Bluetooth capability with the uPyxis 2.0 mobile app for rapid field deployment in minutes.





LSR-801L LoRa Capable Radar Level Sensor



Description

The LSR-801 Series sensors are W-band FMCW continuous frequency modulation radar level transmitters. They provide continuous level measurement up to 591 inches (49.2 ft. or 15m) with 4-20 mA output as well as RS485, Bluetooth 5.0®. The LSR-801L is also equipped with LoRa (Long Range Radio) digital output for long-distance wireless level sensor data access.

The LSR-801 Series can be wirelessly configured via the Pyxis uPyxis® app for Mobile or Desktop devices enabling rapid integration and deployment in the field. The sensors should be powered by a 24 VDC external power supply and are ideal for use with commonly used OEM controllers, PLC or DCS systems. This non-contact liquid level sensor platform is well suited for corrosive liquids and can be used for industrial, municipal and process liquid storage as well as chemical feed applications.

Long Range Data Transmission up to 1.8km away!

Features

- Radar Liquid Level Measurement up to 15m
- Embedded Transmitters 4-20mA/RS-485
- Bluetooth® 5.0 for Mobile Configuration
- 24VDC Power with Smart Switch Capability
- PVDF Transducer / 6P Polycarbonate Enclosure



LSR-803L Radar Level Sensor



Description

The LSR-803 Series sensors are W-band FMCW continuous frequency modulation radar level transmitters. They provide continuous level measurement up to 591 inches (49.2ft. or 15 m) with 4-20mA output as well as RS-485 and BlueTooth® 5.0. The LSR-803L is also equipped with LoRa (Long RangeRadio) digital output for long-distance wireless level sensor data access. The LSR-803 Series has a 1.3" OLED display and 4 buttons for quick configuration and can be wirelessly configured via the uPyxis® app for Mobile or Desktop devices enabling rapid integration and deployment in the field. The sensors are powered by a 24 VDC /2.0W external power supply or 4-AA alkaline batteries and are ideal for use with commonly used OEM controllers, PLC or DCS systems. This non-contact liquid level sensor platform is well suited for corrosive liquids and can be used for industrial, municipal and process liquid storage as well as chemical feed applications.

Long Range Data Transmission up to 1.8km away!

Features

- Radar Liquid Level Measurement up to 15m
- Embedded Transmitters 4-20mA/RS-485
- Bluetooth® 5.0 for Mobile Configuration
- 24VDC Power with Smart Switch Capability
- PVDF Transducer / 6P Polycarbonate Enclosure



LG-100 LoRa Long Range Radio Receiver & Converter

Description

The LG-100 is a LoRa enabled receiver device designed to capture data via LoRa (Long Range Radio) communications and convert the received data into Modbus RS-485 and 4-20mA outputs for connection to multiple device formats.

It comes equipped with a 1.3-inch OLED display and a simple four button layout for easy wireless configuration. Effortlessly connect with the uPyxis® 2.0 Mobile and Desktop app, enabling rapid deployment in the field. The LG-100 LoRa receiver is powered by a 24 VDC/1.0W external power supply. Making it ideal for use with commonly used OEM controllers, PLC or DCS systems. The LG-100 LoRa receiver is designed to offer a wireless data communication solution for critical industrial applications with great flexibilities at an affordable cost. This device allows direct radio connection to any Pyxis LoRa integrated sensor. As well as easily connecting to the Pyxis LG-50 LoRa converter. This enables wireless radio use with any standard non-LoRa Pyxis sensor

Features

- Receives LSR-801L or LSR-803L Data from up to 1.8km away
- Useful to relay readings across a large building or complex

Contact Us at order@pyxis-lab.com for More Information...

PANEL SOLUTIONS

Pyxis Lab[®] offers a variety of pre-assembled, panel-mounted sensor, display and data logging terminal solutions. These platforms are designed to offer the user a rapidly deployed sensor solution that provides live data display, sensor calibration interface, data logging and sensor signal pass-through to any receiving controller, PLC or DCS network.



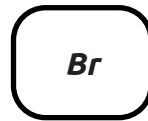
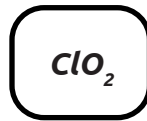
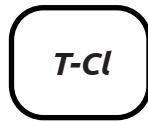

IK-765-B Series Auto-Brushing Oxidizer + pH Analyzers

Product Description

The IK-765SS-B series are dual-parameter inline water analyzers specifically designed as a 'Turn-Key' monitoring solution for challenging water applications including cooling water, food and industrial process water, raw water, and treated wastewater effluent applications. The IK-765SS-B series offers highly accurate, real-time measurement, display, and data-logging of up four oxidizer measurement formats as well as pH and temperature utilizing proprietary Pyxis Lab smart sensor technology, coupled with a Pyxis UC-50 micro display and data logging terminal. The IK-765SS-B also incorporates a uniquely designed automated mechanical brush flow assembly which is directly controlled via the UC-50 display to maintain optimum sensor electrode cleanliness in the most challenging of system water. The IK-765SS-B series is offered in a convenient and easy to integrate panel mounted format for rapid installation and simple maintenance.

The IK-765SS-B series analyzer is offered in four sensor formats depending on the desired oxidant being measured. The panel design is equipped with the propriety Pyxis ST-765SS Series smart sensors based on application needs. The ST-765SS series sensors measure Free Chlorine (FCL), Total Chlorine (TCL), Bromine (Br), Chlorine Dioxide (CLO), or Monochloramine (NCL) in addition to pH and temperature of the sample water. This Pyxis sensor design is membrane-free and based on unique principles incorporating Pyxis' advanced technology in the field of bare-gold electrochemical detection. The ST-765SS-FLC (Free Chlorine + pH), ST-765SS-TCL (Total Chlorine + pH), ST-765SS-Br (Bromine + pH) ST-765SS-CLO (Chlorine Dioxide + pH), ST-765SS-DCL (Free Chlorine + Sulfite + pH) and ST-765SS-NCL (Monochloramine + pH) sensors measure the oxidant level and pH simultaneously while performing temperature and pH compensation for the measurement of oxidant based on conditions present in the application of use. Each IK-765SS-B panel is also equipped with the FR-300-PLUS mechanical brushing flow assembly to ensure constant electrode cleanliness. The UC-50 micro display/data logging terminal is prewired to the ST-765SS series sensor of in RS-485 Modbus format with fully integrated sensor diagnostics and calibration interface. This unique platform with internal sensor compensation results in a highly accurate oxidizer measurement consistent with DPD/Indophenol wet chemistry methodology as high as pH 9.0+ and meets EPA-334.0 and ISO-7393 compliance.

ST-765SS Series Sensors

Pyxis Lab® ST-765SS Oxidizer + pH Series are multiparameter composite sensors used for the measurement of residual Free Chlorine, Total Chlorine, Chlorine Dioxide, Bromine, Sulfite, Ozone, Monochloramine or Dechlorination (Combo F-Cl + SO₃ Sensor), pH & Temperature in compliance with EPA 334.0 & ISO-7393 Guidelines. The sensors advanced PCB offers built-in temperature & pH parameter compensation (up to pH 9.0+) algorithms eliminating the need for a supplemental pH sensor & controller. Unique Bare-Gold electrode technology for residual oxidizer measurement eliminates membranes & electrolyte solution replenishment commonly associated with conventional sensors. The ST-765SS Series has a uniquely designed flat bubble pH electrode design for reduced fouling potential. Reduce your maintenance & cost versus colorimetric chlorine measurement or conventional electrochemical sensors by utilizing a replaceable electrode head (EH-765) for this sensor, allowing for years of reliable service. The ST-765SS Series may be calibrated in-situ after cleaning via DPD Free Chlorine, Bromine or Chlorine Dioxide wet chemistry test measurement of active sample.



Brushing Reservoir

The FR-300 Plus is a magnetic coupling motorized brush flow assembly that provides an inline mechanical cleaning of the ST-765SS enabling sensor accuracy in challenging industrial cooling & process waters. This device enhances the convective mass transport of the oxidizer analyte to the sensor surface eliminating the need for precision flow control. The FR-300 Plus also provides supplemental deactivation protection of the bare-gold electrode for long-life, stability and accuracy. The brushing frequency & rotational speed may be controlled via RS-485 from the UC-50 terminal. The FR-300 Plus contains a 'chemical detergent injection port' in the assembly housing allowing for the optional injection of cleaning agents at the brush head for extremely challenged waters containing oils or grease. The FR-300 Plus may be operated at a broad range of sample flow from 200 & 800mL per minute with an inlet pressure of ≤30psi. The outlet flow line may be diverted to drain or returned to an atmospheric tank/sump within the process itself for reuse.



Learn More & Watch our Launch Video...





IK-765-BP Series Auto-Brushing Oxidizer + pH Analyzers



Product Description

The OXIPANEL-PLUS IK-765-BP series are pre-mounted inline multi-parameter analyzers with integrated ultrasonic flow control specifically designed as a 'Turn-Key' monitoring solution for challenging water applications including cooling water, food and industrial process water, raw water and treated wastewater effluent applications. The OXIPANEL-PLUS series offer highly accurate, repeatable, and real-time measurement of multiple oxidizer species as well as pH, ORP and temperature utilizing proprietary Pyxis Lab smart sensor technology, coupled with a Pyxis UC-80 color touch screen display/data logging terminal and the Pyxis FS-100 ultrasonic flowmeter with regulating valve. The OXIPANEL-PLUS also incorporates the uniquely designed FR-300-PLUS automated mechanical brush flow assembly to maintain optimum sensor electrode cleanliness in the most challenging water where conventional membrane amperometric or wet chemistry analyzers would fail.

The OXIPANEL-PLUS IK-765-BP series are offered in four sensor formats depending on the desired oxidant being measured. The panel design is equipped with the propriety Pyxis ST-765SS Series smart sensor platform based on application needs. The ST-765SS Series sensors measure Free Chlorine (FCL), Total Chlorine (TCL), Bromine (Br) or Chlorine Dioxide (CLO) in addition to pH, ORP and temperature of the sample water. This Pyxis sensor design is membrane-free and based on unique principles incorporating Pyxis' advanced technology in the field of bare-gold electrochemical detection. All versions of the ST-765SS-Series sensor measure the oxidant level and pH simultaneously while performing temperature and pH compensation for the measurement of oxidant based on conditions present in the application of use. Each OxiPanel-PLUS panel is also equipped with the FR-300-PLUS mechanical brushing flow assembly to ensure constant electrode cleanliness and the UC-80 color touch screen display and data logging terminal. This unique platform with internal sensor compensation results in a highly accurate oxidizer measurement consistent with DPD wet chemistry methodology as high as pH 9.0+ and meets EPA-334.0 and ISO-7393 compliance. The OXIPANEL-PLUS series also offers the FS-100 ultrasonic flow sensor and motor valve control module providing precise measurement and control of the incoming water sample flow based on user defined set-point without the challenges commonly associated with mechanical flow measurement in dirty water applications.

Bonus Features - UC-80 Upgraded Display & Data Logging Terminal

Each OxiPanel-PLUS is provided with one UC-80 display which powers the ST-765SS Series sensor, FR-300- PLUS, FS-100 and valve based on the user programmed flow setpoint and system operation. UC-80 touch screen display/data logger provides sensor calibration & diagnostic interface with 3x 4-20mA, RS-485 and TCP output with dual 24 VDC relays (Active or Passive).

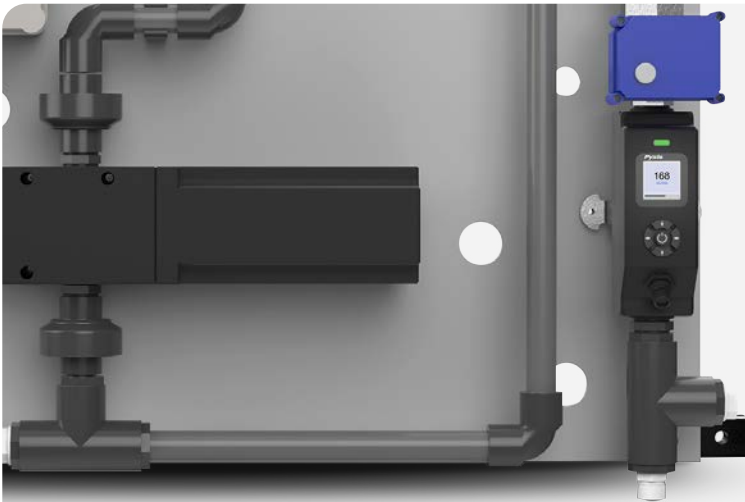

Bonus Features - FS-100 Flow Meter & Control Valve

The Pyxis FS-100 is a state-of-the-art ultrasonic flowmeter that operates on the principle of transit time difference with a measurement range of 0 – 3,000 mL/min and resolution of 1mL. The sensors advanced PCB design offers built-in temperature compensation to eliminate the effect of temperature with instantaneous, accumulated, and controlled water flow based on user setpoint within the sensor itself. The sample flow rate is controlled via PID logic from the flow sensor to the pre-mounted motor valve on the OxiPanel-PLUS analyzer.

Learn More & Watch our Launch Video...





DW-2100P Series Drinking Water Panels

Description

The DW-2100P series are multi-parameter inline water analyzers designed as a 'Turn-Key' monitoring solution for clean water applications, including drinking water networks, secondary water supply & decorative/swimming water applications. The DW-2100P series offers accurate, real-time measurement, display & data-logging of Ultra-Low Turbidity, Residual Chlorine, pH & Temperature utilizing our proprietary smart sensor technology, coupled with a touch screen display & data logging terminal. The DW-2100P series is offered in a convenient and easy to integrate panel mounted format for rapid installation & simple maintenance and meets USEPA-180.1 & 334.0 and ISO-7027 compliance.

The DW-2100P series analyzer integrates two Pyxis Lab® smart sensors. The ST-765SS-FCL measures Residual Chlorine, pH & Temperature of the sample water. This membrane-free & based on unique principles & incorporate advanced technology in the field of bare-gold electrochemical detection. The ST-765SS-FCL sensor integrates temperature & pH compensation for the measurement of Residual Chlorine based on conditions present in the application of use. This unique internal compensation results in a highly accurate oxidizer measurement consistent with DPD wet chemistry methodology as high as pH 9.0.

Learn More at www.pyxis-lab.com/dw-series



OXIPANEL

IK-765SS Residual Chlorine or ClO₂ Monitoring Panel

Description

The IK-765SS series is a pre-assembled Residual Chlorine or Chlorine Dioxide + pH + Temperature monitoring panel consisting of the ST-765SS-FCL (Residual Chlorine) sensor or ST-765SS-CLO (Chlorine Dioxide) sensor with a mounted FR-50 flow reservoir and the UC-50 display & data logging terminal. This platform offers real-time display, data-logging and signal output capability of sample water Residual Chlorine or Chlorine Dioxide, pH and Temperature. The UC-50 is a microprocessor display/data-logging terminal that has been pre-configured to connect to Pyxis Lab® inline sensors with fully integrated calibration interface and signal pass-through.

When any Pyxis Lab® sensor is connected to the UC-50 in RS-485 Modbus, the UC-50 automatically recognizes the sensor and configuration for immediate data display, logging and communication. The user may also configure and calibrate the output signal and contact relay through the UC-50 interface. The IK-765SS analyzer can be applied to a potable water piping network, secondary water supply and water quality monitoring of domestic and clean industrial applications. The IK-765SS meets USEPA-334.0 and ISO-7027 compliance.

Learn More at www.pyxis-lab.com/dw-series



DW-739 Series Turbidity Drinking Water Panel

Description

The DW-739 series are single parameter inline turbidity analyzers specifically designed as a 'Turn-Key' monitoring solution for clean water applications including drinking water networks and secondary water supply networks. The DW-739 series offers highly accurate, real-time measurement, display and data-logging of Ultra-Low Turbidity utilizing proprietary Pyxis Lab® smart sensor technology, coupled with the UC-100 touch screen display & data-logging terminal. The DW-739 series is offered in a convenient and easy to integrate panel mounted format for rapid installation and simple maintenance.

The DW-739 series analyzer integrates the LT-739 ultra-low turbidity sensor installed in the FR-100 flow reservoir. The LT-739 sensor offers a unique flat surface distal end in a quartz glass plate, allowing for extended cleanliness, easy maintenance and prevention of air bubble interference. With a detection range of up to 40NTU and an industry low resolution of 0.001NTU, the LT-739 sensor is designed for optimal accuracy and performance with a wide range of turbidity water samples from raw influent to treated effluent. The LT-739 uses 90° surface scatter configuration and Warm White Light (LED) or Infra Red (LED) and is EPA-180.1 and ISO-7027 compliant respectively.

Learn More at www.pyxis-lab.com/dw-series



DW-765-FCL Free Chlorine + pH Analyzer

Description

The DW-765SS-FCL is a dual-parameter inline water analyzer specifically designed as a 'Turn-Key' monitoring solution for clean water applications including drinking water networks, secondary water supply, bottled water and decorative water applications. The DW-765SS-FCL offers highly accurate, realtime measurement, display and data-logging of Free-Residual Chlorine, pH and Temperature utilizing proprietary Pyxis Lab smart sensor technology, coupled with a Pyxis UC-80 microdisplay and data logging terminal. The DW-765SS-FCL is offered in a convenient and easy to integrate panel mounted format for rapid installation and simple maintenance.

Each DW-765SS panel is also provided with the FR-50 Flow Reservoir, Hall Effect Digital Flow Meter and UC-80 micro display/data logging terminal prewired to the ST-765SS sensor in RS-485 modbus format with fully integrated sensor diagnostics and calibration interface.

This unique platform with internal sensor compensation results in a highly accurate oxidizer measurement consistent with DPD wet chemistry methodology as high as pH 9.0+ and meets EPA334.0 and ISO-7393 compliance.



Contact Us for Details & Pricing at order@pyxis-lab.com



WQMS-2000 Series Water Quality Management Analyzer

Description

The WQMS-2000 series are multi-parameter inline water analyzers specifically designed as a 'Turn-Key' monitoring solution for clean beverage/water applications including bottled Spring and Reverse Osmosis drinking water, beverage manufacturing as well as primary/secondary water supply networks. The WQMS-2000 series offers highly accurate, real-time measurement, display and data logging of Ultra-Low Turbidity, Ozone, pH, Conductivity, Total Dissolved Solids and Temperature utilizing proprietary Pyxis Lab smart sensor technology, coupled with a Pyxis touch screen display and data logging terminal. The WQMS-2000 series are offered in a convenient and easy to integrate panel mounted format for rapid installation and simple maintenance.

The WQMS-2000 series analyzer integrates three unique Pyxis smart sensors. The ST-765SS-O3 measures Ozone, pH and temperature of the sample water. This sensor is membrane-free and based on unique principles incorporating Pyxis' advanced technology in the field of bare-gold electrochemical detection. The ST-765SS-O3 sensor measure ozone residual while simultaneously measuring pH and performing oxidizer temperature and pH compensation based on conditions present in the application of use. This unique internal compensation results in a highly accurate oxidizer measurement consistent with DPD wet chemistry methodology as high as pH 9.0+ and is EPA-334.0 and ISO-7393 compliant with zero-burn in time and instantaneous response.

Contact Us for Details & Pricing at order@pyxis-lab.com

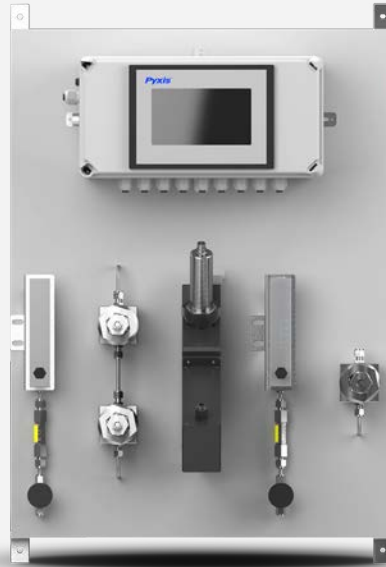

WQMS-2300 Water Quality Management Analyzer

Description

The WQMS-2300 is a dual-sample multi-parameter inline water analyzer specifically designed as a 'Turn-Key' monitoring solution for clean water applications including bottled Spring and Reverse Osmosis drinking water, beverage manufacturing as well as primary/secondary water supply networks. The WQMS-2300 offers highly accurate, real-time measurement, display and data-logging of dual-sample water streams for Ozone, with single water sample analysis for Ultra-Low Turbidity, pH, Conductivity, Total Dissolved Solids and Temperature utilizing proprietary Pyxis Lab smart sensor technology, coupled with a Pyxis touch screen display and data logging terminal. The WQMS-2300 is offered in a convenient and easy to integrate panel mounted format for rapid installation and simple maintenance.

The WQMS-2300 analyzer integrates a total of four Pyxis smart sensors. The dual ST-765SS-O3 sensors measure Ozone, pH and temperature of the two independent flowing / measured water sample streams for the purposes of Ozone disinfectant injection control and pre-bottle filler monitoring verification. This sensor is membrane-free and based on unique principles incorporating Pyxis' advanced technology in the field of baregold electrochemical detection. These sensors measure ozone residual while simultaneously measuring pH and performing oxidizer temperature and pH compensation based on conditions present in the application of use consistent with wet chemistry methodology.

Contact Us for Details & Pricing at order@pyxis-lab.com



DW-2030P Multi-Parameter Analyzer for Bottled Water

Description

The DW-2030P series is a multi-parameter inline water analyzer specifically designed as a 'Turn-Key' monitoring solution for clean beverage/water applications including bottled Spring and Reverse Osmosis drinking water, beverage manufacturing as well as primary/secondary water supply networks. The DW-2030P series offers highly accurate, real-time measurement, display and datalogging of Ultra-Low Turbidity, Residual Chlorine, pH, Conductivity, Total Dissolved Solids and Temperature utilizing proprietary Pyxis Lab smart sensor technology, coupled with a Pyxis touch screen display and data logging terminal.

The DW-2030P series is offered in a convenient and easy to integrate panel mounted format for rapid installation and simple maintenance. The DW-2030P series analyzer integrates three unique Pyxis smart sensors. The ST-765SS-FCL measures Residual Chlorine, pH and temperature of the sample water. This sensor is membrane-free and based on unique principles incorporating Pyxis' advanced technology in the field of bare-gold electrochemical detection. The ST-765SS-FCL sensor may be field calibrated to measure free or total chlorine while simultaneously measuring pH and performing oxidizer temperature and pH compensation based on conditions present in the application of use. This unique internal compensation results in a highly accurate oxidizer measurement consistent with DPD wet chemistry methodology as high as pH 9.0+ and is EPA-334.0 and ISO-7393 compliant.

Contact Us for Details & Pricing at order@pyxis-lab.com



OXIPANEL

IK-765SS-O3 Ozone + pH Analyzer for Bottled Water

Description

The IK-765SS-O3 is a dual-parameter inline water analyzer specifically designed as a 'Turn-Key' monitoring solution for clean water applications including bottled water production, drinking water networks, secondary water supply and alternative cleanwater ozone treatment applications. The IK-765SS-O3 offers highly accurate, real-time measurement, display and data-logging of Ozone (O₃), pH and Temperature utilizing proprietary Pyxis Lab smart sensor technology, coupled with a Pyxis UC-80 touch screen display and data logging terminal. The IK-765 series is offered in a convenient and easy to integrate panel mounted format for rapid installation and simple maintenance.

The IK-765 Ozone analyzer is equipped with the propriety Pyxis ST-765SS-O3 smart sensor design which is membrane-free and based on unique principles and incorporates Pyxis' advanced technology in the field of bare-gold electrochemical detection. The sensor measures the Ozone level and pH simultaneously while performing temperature and pH compensation for the measurement of oxidant based on conditions present in the application of use. The IK-765SSO3 panel is also provided with the ST-007 stainless steel flow reservoir with inlet rotameter, digital flow meter and UC-80 display/data logging terminal prewired to the sensor in RS-485 modbus format with fully integrated sensor diagnostics and calibration interface. This unique platform with internal sensor compensation and self-cleaning results in a highly accurate ozone measurement consistent with DPD wet chemistry methodology as high as pH 9.0+ and meets EPA-334.0 and ISO-7393 compliance.



OXIPANEL

IK-765SS-SO3 Sulfite + pH Analyzer

Description

The IK-765SS-SO3 is a dual-parameter inline water analyzer specifically designed as a 'Turn-Key' monitoring solution for clean water applications to monitor Sulfite in water commonly used in water and process applications for scavenging of Chlorine and Oxygen. The IK-765SS-SO3 offers highly accurate, real-time measurement, display and data-logging of Sulfite (SO₃), pH and Temperature utilizing proprietary Pyxis Lab smart sensor technology, coupled with a Pyxis UC-80 touch screen display and data logging terminal. The IK-765 series is offered in a convenient and easy to integrate panel mounted format for rapid installation and simple maintenance.

The IK-765 Sulfite/pH analyzer is equipped with the propriety Pyxis ST-765SS-SO3 smart sensor design which is membrane-free and based on unique principles and incorporates Pyxis' advanced technology in the field of bare-gold electrochemical detection. The sensor measures the Sulfite level and pH simultaneously while performing temperature and pH compensation for the measurement of the reducing agent based on conditions present in the application of use. The IK-765SS-SO3 panel is also provided with the ST-007 stainless steel flow reservoir with inlet rotameter, digital flow meter and UC-80 display/data logging terminal prewired to the sensor in RS-485 Modbus format with fully integrated sensor diagnostics and calibration interface.

This unique platform with internal sensor compensation is factory calibrated by Pyxis Lab using precise Sulfite concentration standards in an Argon purged environment resulting in highly accurate Sulfite detection consistent with Titration, Colorimetry or Fluorescence methodology as high as 100ppm.



SFA-765SS-TCL 'True & Virtual' Total Chlorine + pH

Description

The SFA-765SS-TCL is a total (combined) chlorine measured in analyzer specifically designed as a 'TurnKey' monitoring solution for clean water applications including bottled water production, drinking water networks, secondary water supply and decorative/domestic water applications. The SFA765SS-TCL offers highly accurate, real-time measurement, display and data-logging of total (combined) chlorine both as 'True' or as 'Virtual' form, pH and temperature utilizing proprietary Pyxis Lab smart sensor technology. The analyzer offers measurement with and without the injection of potassium iodide/acetic acid reagent based on the user desired mode of measurement. Coupled with a Pyxis UC-80 micro display and data logging terminal, digital flow meter and peristaltic chemical reagent metering pump, this analyzer is packaged in a convenient and easy to integrate panel mounted format for rapid installation and simple maintenance.

Each SFA-765SS-TCL panel is equipped provided with an ST-001 inline tee assembly, rotameter, inline Hall-Effect digital flow sensor, peristaltic iodide reagent injection pump and UC-80 micro display/data logging terminal which is prewired to the sensor in RS-485 modbus format with fully integrated sensor diagnostics and calibration interface. This unique platform with internal sensor compensation results in a highly accurate total (combined) chlorine measurement in both 'True' and 'Virtual' forms consistent with DPD wet chemistry methodology as high as pH 9.0+ and is EPA-334.0 and ISO-7393 compliant.

Contact Us for Details & Pricing at order@pyxis-lab.com



IK-73X Plus Series Auto-Brushing Turbidity Analyzers

Description

The IK-73X-PLUS series are single parameter inline turbidity analyzers specifically designed as a 'Turn-Key' monitoring solution for industrial water applications including cooling, process, influent and wastewater effluent. The IK-73X-PLUS series offers auto-brushing, highly accurate, real-time measurement, display and data-logging of turbidity utilizing proprietary Pyxis Lab smart sensor technology, coupled with the Pyxis touch screen display and data logging terminal. The IK-73X-PLUS series is offered in a convenient and easy to integrate panel mounted format for rapid installation and simple maintenance.

The IK-73X-PLUS series analyzer integrates the LT-739 and LT-736 ultra-low turbidity sensor platforms installed in the FT-100-PLUS auto-brushing flow tee. The LT-73X series sensor offers a unique flat surface distal end in a quartz glass plate, allowing for rapid inline auto-cleaning and prevention of air bubble interference. With a detection range of 0.000 to 40 NTU (LT-739) and 0.000 – 1,000 NTU (LT-736) and an industry low resolution of 0.002 NTU, the LT-73X series turbidity sensors are designed for optimal accuracy and repeatability with minimal sensor drift. The LT-73X series sensors use 90° surface scatter configuration in Warm White Light (LED) and are EPA-180.1 compliant.

Contact Us for Details & Pricing at order@pyxis-lab.com



MA-CIP Clean-In-Place Panel for Pyxis Lab® Sensors

Description

The Pyxis MA-CIP-1 is a self-sufficient bypass 'Clean-In-Place' panel specifically designed for use with Pyxis Lab ST and HM Series inline probes. This device may be used as a stand-alone control panel in applications where Pyxis inline probes are exposed to heavy fouled water or process applications requiring a higher frequency of chemical cleaning. The MA-CIP-2 panel comes as a plug-and-play platform and includes a 7-inch LCD capacitive touch screen PLC capable displaying the input sensor value, trend graph, probe calibration and cleanliness diagnostics interface, input data storage, alarm output, remote data logging and easy programming for self-cleaning frequency and duration.

MA-CIP-2 operates on 100-240VAC / 22W power supply and offers 1x-4-20mA and RS485 Modbus RTU output. Equipped with ¾" NPT-CPVC plumbing, bypass isolation valves, recirculating pump, inline ST-001 Pyxis Tee, chemical injection port and chemical reagent pump shelf and pump, this unique accessory enables users of Pyxis ST and HM Series inline probes to cost-effectively and rapidly integrate an automated cleaning cycle.

A wide variety of Pyxis ST and HM Series inline probes are equipped with proprietary internal cleanliness diagnostics capability. MA-CIP-2 may be connected to the Pyxis sensor in RS-485 Modbus format and enable real-time cleanliness diagnosis/alarming of the sensor to automatically activate the bypass clean-in-place process. This unique differentiation of Pyxis inline sensors provides the user with a truly "automated" process to ensure optimum sensor cleanliness and accuracy at all times.

Contact Us for Details & Pricing at order@pyxis-lab.com



IK-765P-DCL Dechlorination Analyzer for Fresh or Sea Water

Description

The IK-765P-DCL inline residual Chlorine and Sulfite panel is a multi-parameter inline water analyzer specifically designed as a 'Turn-Key' monitoring solutions for clean water applications that require constant validation of chlorine removal prior to membrane or other critical to quality system applications. This proprietary technology offers highly accurate and simultaneous measurement, display, and data-logging of Chlorine (user selected as Free or Total Chlorine), Sulfite residual, pH, Temperature, and sample flow rate utilizing proprietary Pyxis Lab smart sensor technology, coupled with a UC-80 touch screen display and data logging terminal. The IK-765P-DCL is offered in CPVC construction enabling its use in both Fresh Water and Sea Water monitoring applications. This analyzer design is a convenient and easy to integrate panel mounted solution for rapid installation and simple maintenance.

The IK-765P-DCL analyzer panel design is equipped with the propriety ST-765 Series smart sensor configured to simultaneously measure oxidizer as Free or Total Chlorine and Sulfite concentration while also measuring pH and temperature of the sample water for refined compensation. Additionally, the analyzer is equipped with the FS-100 ultrasonic flow sensor for real time, precise sample flow measurement and regulation.

This Pyxis ST-765 Series sensor design is membrane-free and based on unique principles and incorporates Pyxis' advanced technology in the field of bare-gold electrochemical detection. The ST-765P-DCL (CPVC) sensor include on this analyzer measures the oxidant level, sulfite level and pH simultaneously while performing temperature and pH compensation for the measurement of oxidant based on conditions present in the application of use. This technology can provide significant value in a variety of water and process applications helping to extend equipment life and performance while improving regulatory compliance.

Contact Us for Details & Pricing at order@pyxis-lab.com



Guardian IK-2000 Series Multiparameter Water Quality Analyzers

Description

The GUARDIAN IK-2000 series are multi-parameter inline water quality analyzers specifically designed as a 'Turn-Key' monitoring solution for boiler feedwater and chemical treatment applications ranging from low to high pressure operations. The Guardian boiler feedwater series is offered on "ONE-PANEL" design, with a variety of Pyxis Lab smart sensor options based on the application and need. This format allows the user the flexibility to begin with a base model and add sensor capability over time and as desired, without the need to replace or configure anything. Simply plug in the new sensor to the available sensor pigtail on the analyzer, and the Guardian will automatically recognize, configure, and initiate operation, calibration interface and data logging of the added sensor. With all sensor options installed, the Guardian boiler feedwater series offers highly accurate and repeatable, real-time measurement, display, and data-logging of Dissolved Oxygen (ppb), Temperature (°C/°F), pH, ORP (mV), Sulfite (ppm), Conductivity ($\mu\text{S}/\text{cm}$) and Total Dissolved Solids (ppm) utilizing proprietary Pyxis Lab smart sensor technology coupled with a Pyxis color touch screen display and data logging terminal.

This series should always be installed after a sample cooler and are offered in a convenient and easy to integrate panel mounted format using only 304 and 316L stainless steel with SwageLok™ compression fittings to ensure optimum sensor performance and integrity. With an integrated maintenance shelf for easy sensor calibration and maintenance, the Guardian Boiler Feedwater Series was designed with the user in mind.

Contact Us for Details & Pricing at order@pyxis-lab.com



Watch Our Video



Nano-Flow™ Sample Flow Measurement & Control Module

Description

The Pyxis Lab® Nano-Flow Control Module is a stand-alone water flow measurement and control solution designed for use in critical cooling and process water sample flow applications. This unique platform provides precise flow measurement and regulation and may be installed upstream of inline sensors in water systems that are subject to pressure and flow variation challenges. The Nano-Flow module is offered in a convenient and easy to integrate micro-panel design is equipped with the Pyxis FS-100 ultrasonic flowmeter with a display, which directly controls a pre-mounted regulating valve through a simple to program user interface.

The new FS-100 is a state-of-the-art ultrasonic flow meter that operates on the principle of transit time difference with a measurement range of 0-3,000mL/min and resolution of 1mL. The sensors advanced PCB design offers built-in temperature compensation to eliminate the effect of temperature with instantaneous, accumulated and controlled water flow based on user setpoint within the sensor itself. The flow control module also incorporates an electric box for panel power supply, internal regulating valve control and FS-100 output flow signal wiring both 4-20mA and RS-485 Modbus for connection to any OEM controller, PLC or DCS.

Features

- Panel Mounted for Simple Installation and Startup
- 0–3,000mL/min Ultrasonic Flow Sensor
- User Programmed (FS-100 Setpoint) Control Valve
- Isolated 4-20mA and RS-485 Modbus
- Real-Time Flow Rate Trend Chart
- Built-In Temperature Sensor with Auto-Compensation
- Displays Instant Flow Rate & Accumulated Volume
- Large Color LED Indicator for Operational State



PortaPanel™ Ultra-Low Luminescent DO Analyzer

Description

The ST-774 PortaPanel™ is a prefabricated panel ideally suited for those desiring to use the ST-774 Ultra-Low DO Sensor with a local display and data acquisition in a portable fashion for oxygen measurement (i.e. de-aerator performance studies). The PortaPanel™ is a pre-mounted, easy-to-carry, self-standing 316L stainless steel panel with the ST-774 sensor, flow cell and appropriate water sample/calibration gas flow hardware. The panel comes equipped with an integrated UC-50 display & data logging terminal which is connected to the ST-774 via RS-485 Modbus, offering live data display, calibration interface and data logging of the sensor. The UC-50 offers (1) contact relay output and has RS-485 Modbus and (1) 4-20mA output for passing the sensor value onto another device. The UC-50 also offers Bluetooth® 5.0 capabilities for uPyxis® interface and provides a USB input for rapid data download as a .CSV file.



Features

- Ideal for Dissolved Oxygen Studies
- Portable, Free-Standing 316LSS Panel
- Fully Integrated Flow Cell + Plumbing
- 1/4" OD Stainless Steel Swagelok
- 0–2,000ppb Measurement Range
- 0.1ppb Lower Detection Limit
- Built-In Temperature & Pressure Sensors
- UC-50 Display & Data Logging Terminal
- Lightweight, Compact Design
- Affordable Purchasing Price (Trials Available)



CHEMICALS & ACCESSORIES

Pyxis Lab® manufactures all necessary Tracer Chemicals, Calibration Standard Solutions, Powder Pillow Reagents and Electronic/Hardware accessories required for the use of on-going maintenance, calibration and precision accuracy of the Pyxis Lab® inline sensor and handheld product line.



Pyxis

PTSA Standard
PTSA 100, 100 ±1 ppb
Batch D146; Exp. 2-15-2022
service@pyxis-lab.com
www.pyxis-lab.com
500 ml
SKU: 21001

Pyxis

**pH 10.0
Calibration
Solution
D-70**
500 ml
SKU:57006

Pyxis

**pH 7.0
Calibration
Solution
D-71**
500 ml
SKU:57004

Pyxis

**pH 4.0
Calibration
Solution
D-70**
500 ml
SKU:57005

Pyxis

Turbidity 2 NTU Standard
Batch D51 Exp. 6-30-2022
service@pyxis-lab.com
www.pyxis-lab.com
SKU: 57010-4
500 ml

Pyxis Lab 1729 Majestic Drive, Suite 5
Lafayette, CO 80026
866-203-8397
www.pyxis-lab.com
Made in the U.S.A.

Pyxis Lab 1729 Majestic Drive, Suite 5
Lafayette, CO 80026
866-203-8397
www.pyxis-lab.com
Made in the U.S.A.

Pyxis Lab 1729 Majestic Drive, Suite 5
Lafayette, CO 80026
866-203-8397
www.pyxis-lab.com
Made in the U.S.A.



All Necessary Calibration Standard Solutions

Description

Liquid standards & solid state calibration kits are manufactured & prepared to the highest degree of quality & precision supporting the maintenance of all Pyxis Lab® inline & handheld devices. Certificate of analysis & SDS, as well as a full calibration standard line offering available at www.pyxis-lab.com or by email request at sales@pyxis-lab.com.

Popular Calibration Solutions

- **PTSA** | 30, 50, 100, 200 or 300ppb
- **PTSA1010** | 100ppb + 1,000 μ S/cm Conductivity
- **PTSA 100 + 50FL** | 100ppb PTSA + 50ppb Fluorescein
- **TAG** | 10, 20ppm Tagged Polymer
- **Fluorescein** | 10, 50, 250, 500ppb
- **Conductivity** | 1,000 μ S/cm, 50,000 μ S/cm
- **pH** | 4.0, 7.0, 10.0, Combination Package
- **Turbidity** | 2, 10, 15, 50, 100, 200, 500, 1,000NTU, Combination Packages
- **ORP** | 200mV
- **HST/TTA** | 1, 2ppm
- **DPD Chlorine** | 1, 2ppm
- **OIW Standards** | 100, 500, 1,000ppm Synthetic Standard Calibration Solutions



Powder Pillow Reagents

Description

As of 2024, Pyxis Lab[®] has been selling two variants of powder pillow reagents for our handheld Chlorine analyzers. Do not worry! Our technology works with other industry standard powder pillow reagent producers such as HACH[®] or Lovibond[®] so please look to those providers for expanded powder pillow reagents offerings.

Powder Pillow Offering

- **Cl-F** | Free Chlorine DPD 10mL Method
- **Cl-T** | Total Chlorine DPD 10mL Method





16mm COD & Oil In Water Extraction Vial Kits

Description

We have developed 16mm reagent vial kits for testing low range COD, high range COD and the proprietary Pyxis Lab® Non-Toxic/Flammable Solvent for extraction testing of oil in water. These kits are offered in 12 or 50 pack bundles and are specifically designed for use in the SP-800, SP-910 & HM-900 analyzers. We also offer 24mm & 16mm adapters enabling easy testing. These adapters are included with any purchase of the SP-800, SP-910 or HM-900 analyzers.



TMB Free & Total Chlorine Dropper Kits

Description

The Pyxis Lab® SP-710 offers both Free & Total Chlorine methods based on the USEPA accepted tetramethylbenzidine (TMB) chemistry. Although less known for its use, the TMB method of Free & Total Chlorine measurement is highly regarded as superior to the DPD method for its rapid result development and superior stability. These unique liquid dropper bottles contain the TMB reagent for Free or Total Chlorine, a pH buffer and a polymeric binder.

When three drops of liquid reagent are administered into the sample cup of the SP-710, the TMB reagent chemically & rapidly reacts with Free or Total Chlorine present to develop a stable yellow colored solution. The SP-710 measures the absorbance value of the resulted yellow solution to directly determine the Free or Total Chlorine concentration in the sample as high as 10.0ppm for each method. Each kit is provided in a 30mL easy to use dropper bottle which is sufficient inventory for up to 230 individual tests offering a far lower cost per test than conventional DPD powder pillows

Features

- Single Liquid Dropper Bottle provides easier use, safety & 230 tests
- TMB Acidic Reaction pH eliminates CaCO₃ & CaCO₄ precipitation common in DPD method
- USEPA Approved for Domestic Water Applications
- Provides Rapid Reaction Results & Superior Stability versus DPD



Inline Sensor & Handheld Cleaning Kits

Description

Our handheld & inline sensors cleaning solution helps ensure the accuracy of your Pyxis Lab® handheld or inline sensor readings. Pyxis Lab® recommends a minimum cleaning frequency of once per month.

High stress applications with excessive suspended solids, LSI or corrosion/scale by-product can result in the need to increase the frequency of cleaning your handheld or inline sensor. The Pyxis Lab® custom inline and handheld field cleaning kits have been specifically designed to target a wide variety of inorganic deposits and foulants commonly seen in cooling, boiler and process water applications.

Features

- Custom Blend of Organic Acid / Reducing Agents & Surfactant
- Targets Inorganic Fouling & Deposition within your Handheld or Inline Sensor
- 500mL Bottles (Larger Volumes Available)
- Cleaning Procedures Provided with the Bottle
- Cotton Swabs & Pipe Cleaners Included (10 each)
- Sufficient Volume for 12 Cleanings



ST-001 Tee Assembly & ST-002 Tee Plug

Description

Quick to assemble and easily replaceable, the ST-001 inline tee assembly comes INCLUDED with every standard Pyxis Lab® inline sensor. This uniquely designed tee assembly is specifically made to ensure proper alignment & fits all CPVC ST-Series inline sensors. The tee offers a 3/4" FNPT Sch. 80 UPVC design that is capable of up to 100psig (120 °F / 49 °C) and arrives with socket & thread adapters with unions.

For sensor removal without any by-pass flow shutdown, Pyxis Lab® offers the ST-002 tee plug as seen below. This plug can be inserted in place of the sensor to allow flow to be maintained through the ST-001 tee assembly after the sensor has been removed.

Features

- 3/4" NPT Sch. 80 UPVC
- Socket & Thread Adapters Provided
- Quick Union Inlet & Outlet
- Unique Pyxis Lab® Inline Sensor Alignment Design
- 100psig Capable (120 °F / 49 °C)
- Fits all ST-Series of Pyxis Lab® Inline Sensors
- (1) ST-001 Tee Included with each Pyxis Lab® Sensor
- ST-002 Plug Available for Sensor Removal



ST-004 1.5" MNPT Pipe Insert Adapter for ST-Series Sensors

Description

This adapter allows you to quickly thread your ST-Series Inline Sensor into a pipe network. The adapter offers a 1.5" MNPT thread with a tee fitting on top for simple installation. Quickly thread the adapter into the pipe fitting, insert your inline sensor and seal the tee for a super simple pipe installation.



MA-150 O-Ring for ST-001 Tee

Description

This is a replacement o-ring for the inline tee kit that arrives with every Pyxis Lab® sensor.

Use this o-ring to properly thread and plug the tee cap, making an air-tight seal and stopping any water from escaping the tee.



ST-007 Tee Assembly for ST-765/ST-71XSS Series

Description

This stainless steel variant of our inline tee assemblies is built specifically for clean water applications and fits several stainless steel sensor variants, including the new & popular ST-765SS Oxidizer + pH inline sensor. The ST-007 tee has a suggested flow rate of 200–400mL/minute & should be installed downstream of a rotameter for CLEAN-WATER APPLICATIONS only!



EH-765 Replacement Sensor Module

Description

The ST-765SS Series of inline oxidizer sensors offer a replaceable, front loading reference electrode assembly that has been independently developed by Pyxis Lab®. This replacement electrode sensor head eliminates the shortcomings associated with membranes and gel replacement while also offering reduced polarization time on start-up. The sensor head offers an electrode life-span potential of up to 2 years barring any mismanagement/maintenance negligence. The flat front-end design of the ST-765SS series makes this platform less prone to contamination or fouling and is super easy to clean.



1, 2, 3, 4 inch NPT Tee Kits

Description

For customers desiring to install Pyxis Lab® sensors into larger bypass or inline piping networks, we offer a variety of alternative NPT tee sizes. Available in 1, 2, 3 or 4 inch fittings.



MA-700 Series Hard Carrying Cases

Description

Hard carrying cases meant for industrial water treatment analytical equipment but can be used as a general-purpose carrying case. The inside of these carrying cases offer removable foam for custom layouts. *Small, Medium & Large Available.*





FDX-10 (Liquid) & FDX-98 (Powder) Pails of PTSA

Description

A fiber drum (55lbs) containing 1,3,6,8-Pyrenetetrasulfonic Acid, Tetrasodium Salt (PTSA), CAS# 59572-10-0. It is recommended to blend FDX-98 dye with water treatment formulation in 1:1,000 weight ratio. The concentration should be controlled at 50-200ppb in recirculation systems for the best monitoring performance.

Features

- Active Ingredient - 1,3,6,8-Pyrenetetrasulfonic Acid, Tetrasodium Salt
- CAS# 59572-10-0
- High Quantum Efficiency, Ideal for Monitoring as low as 50ppb for Cooling & 5ppb for RO
- Colorless at the Target Concentrations & Easy to Dissolve
- Inert Fluorescent Tracer. Great Compatibility with Water Treatment Chemical Formulations!
- Dust-Free for Easy Handling
- Long-Term Stability, 3-Year Shelf Life in the Original Package

Order Information

FDX-98 (55lbs Fiber Drum)
 FDX-10 (40lbs Pail)
 FDX-10 (440lbs Drum)
 FDX-10 (2,200lbs Tote)

Part Numbers

20303
 20201-P
 20201-D
 20201-T



Glass Sample Vials for Testing

Description

Glass sample vials meant to be used with our staple colorimeters (SP-200, SP-910 & SP-800).

Sizes Available

10mL
25mL
16mm



Replacement Batteries

Description

Though our devices have long battery life spans & often use standard AA batteries, some other devices require batteries that are not as common. You can find replacement batteries for the CR-200 Corrosion Sensor & our Wireless pH/ORP Module on our e-store under the accessories section.

www.pyxis-lab.com/shop



DPD Chlorine Secondary Verification Kit

Description

The Pyxis Lab® DPD Chlorine Verification Standard Kit is specifically designed to be used for secondary standard verification to check the accuracy for both Free & Total Chlorine DPD methods on our staple colorimeters (SP-200, SP-800 & SP-910). The secondary standard kit includes four sealed glass vials, an instruction sheet and Certificate of Analysis (COA) with specific tolerances for each concentration.

Included in the kit is the STD0 sample blank vial, which is used to zero the SP-Series of colorimeters. Additional vials containing varying concentrations are also provided and listed below:

- STD0 (Zeroing)
- STDA (0.50mg/L)
- STDB (1.30mg/L)
- STDC (3.60mg/L)

The exact concentration, along with corresponding tolerance range of each vial in the kit is provided in the COA. Pyxis Lab® meters are calibrated at the time of manufacturing. These standards should be read on the meters routinely as a verification check on the unit accuracy per EPA guidelines. The results should be recorded. The SP-Series should measure the concentration of the standards within the concentration tolerance range specified in the COA. If the concentration measured by SP-Series on any standard vial is outside the tolerance range, the SP-Series device should be calibrated using a primary chlorine standard.



Monochloramine Verification Kit

Description

The Pyxis Lab® Monochloramine/Nitrogen Ammonia verification standard kit is specifically designed to be used for secondary standard verification to check the accuracy for the Monochloramine/Nitrogen Ammonia Indophenol method (Low Range) on our colorimeters (SP-200, SP-910, SP-800). The secondary standard kit includes four sealed glass vials, an instruction sheet & Certificate of Analysis (COA) with specific tolerances for each concentration. Included in the kits are the STD0 sample blank vial, which is used to zero the SP-Series colorimeters. Additional vials containing varying concentrations are also provided and listed below:

Monochloramine Low Range

- STD0 (For Zeroing)
- STDA (0.50mg/L – NH₂CL)
- STDB (1.00mg/L – NH₂CL)
- STDC (2.50mg/L -NH₂CL)

Nitrogen-Ammonia Low Range

- STD-0 (For Zeroing)
- STD-A (0.10mg/L – NH₃S)
- STD-B (0.20mg/L – NH₃S)
- STD-C (0.50mg/L – NH₃S)

The precise concentration, along with the corresponding tolerance range of each vial in the kit is provided in the COA (Certificate of Analysis). Pyxis Lab® meters are calibrated at the time of manufacturing. These standards should be utilized on the meters routinely as a verification check on the unit accuracy per EPA guidelines. The results should be recorded.



L-CAL Portable Liquid Formazin Turbidity Calibration Kit

Description

Pyxis Lab® has developed a portable and reusable liquid state calibration kit for rapid calibration of the LT-Series inline ultra-low turbidity sensors. The LT-Series are factory calibrated using certified liquid formazin calibration standards. This unit allows users to calibrate their LT-Series sensors using smaller volumes of Formazin, providing an affordable and reusable solution for long term sensor reliability.

The unique design allows the LT-73X sensor to be easily inserted and calibrated with the sensor in a horizontal position, allowing air bubbles to be evacuated through the integrated air-vent line ensuring superior accuracy of the sensor calibration. The L-CAL has an easy-to-remove lid that allows users to fill and empty the kit with DI water for vessel/sensor cleaning and Formazin calibration standards for sensor calibration.

Principals & Considerations

The precision, resolution and the low detection limit of the LT-73X sensors are not affected by the calibration method, regardless of using certified Formazin standards and the L-CAL kit. The calibration only affects sensor accuracy. The nature of turbidity measurement makes an absolute turbidity value not easily obtainable for any sensor manufacturer although proper standards and methods are followed. For ultra-low turbidity (less than 0.3NTU) measurement using the same methods (ISO-7027, EPA-180.1) it is likely that the values from different sensors can agree within 0.05NTU. As such, the user should choose a calibration method and remain with the same calibration method for consistency.



PowerPACK™ Bluetooth® Auxiliary Adapters

Description

The Pyxis Lab® PowerPACK™ series of Bluetooth® auxiliary adapters are uniquely designed to provide additional power budget and wireless communication to power Pyxis Lab® inline sensors to a receiving microprocessor controller, PLC or DCS with limited or no power supply capability. Offered in a single-channel, dual-channel and four-channel formats, these auxiliary adapters has a built-in 24V DC power supply with 20W capacity. Each PowerPACK™ is also integrated with built-in Bluetooth® 5.0 interface, allowing users to wirelessly pair to all sensors connected with the uPyxis® app for real-time diagnosis, calibration, maintenance and configuration.

PowerPACK™ auxiliary adapters can be utilized in 100VAC to 240VAC power input and provide 24V DC power supply in a direct plug-in format to Pyxis Lab® inline sensors.

PowerPACK 1 offers a single-channel input and output quick adapter cable, containing 4–20mA interface, while **PowerPACK 2** and **PowerPACK 4** extends this capability to two or four individual input and output connection adapters. Additionally, PowerPACK 2 offers RS-485 signal pass-through. Each input is specifically designed for direct connection to standard (7-Pin) Pyxis Lab® inline sensors and output is designed to connect to the Pyxis Lab® standard flying lead cable provided with the PowerPACK™ unit, then terminated to the receiving controller or device. The sensor input glands (bottom of box) and 4-20mA / RS-485 signal output glands (right side of box) are mapped one-to-one by numbered labels. Conversion adapters for Pyxis Lab® 5-Pin and 8-Pin sensors are also available allowing PowerPACK™ to be used with all Pyxis Lab® sensor wiring formats.



MA-Series Inline Bluetooth® Adapters

Description

We have redesigned our MA-Series of Bluetooth® adapters! These updated models offer the same Bluetooth® functionality as their predecessors with NEW features including a live local display, a calibration & diagnostics hub & data-logging capabilities. The Pyxis Lab® MA-Series of inline adapters are uniquely designed accessories that enable Pyxis Lab® sensors to be accessed, viewed, configured and calibrated via the uPyxis® app for mobile or desktop devices. The MA-Series of adapters are offered Bluetooth® 5.0 wireless platform in 7-Pin and 8-Pin formats enabling connectivity to all Pyxis Lab® inline sensors.

Rapid, Installation, Connection & Removal

These adapters are designed to be installed easily and without the need for tools. Each format is rapidly connected with “quick-adapters” designed for its sensor conductor pin format (7-Pin & 8-Pin). When installed, the MA-Series inline adapters utilize the power provided (24V DC) from the controller it is connected to, passing the power supply through to the connected inline sensor. Additionally, each MA-Series inline adapter offers 4-20mA and/or RS-485 Modbus connectivity from the sensor to the receiving controller, PLC or DCS network. The MA-Series adapters may be left inline permanently or installed and removed as a portable accessory device as needed.



MA-NEB USB Bluetooth® Adapter

Quickly insert the MA-NEB into your desktop or laptop & connect to any Bluetooth® enabled device on uPyxis® desktop.



SOFTWARE SOLUTIONS

Monitor, Configure, Calibrate, Diagnose Sensor Cleanliness, Quickly Share Data and/or Configure Custom Alarm Settings on your mobile or desktop device using either the uPyxis® app or our Cloud Data Management Platform.

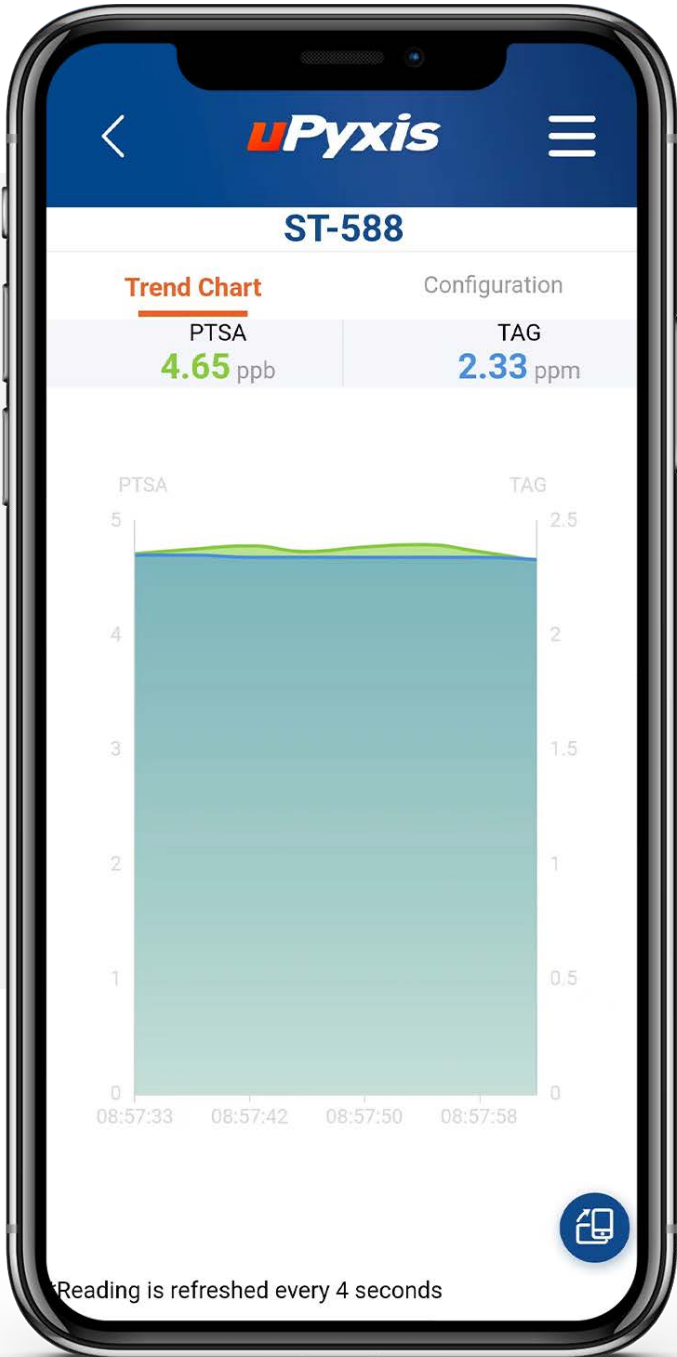

uPyxis™ Mobile & Desktop App

Universal Application for your Pyxis Lab® Devices

The universal application for all your Pyxis Lab® products. Customize, calibrate, monitor and share data from your smart phone or desktop. Our Bluetooth® capable & Bluetooth® enabled - with the MA-Series or PowerPACK™ series of adapters - analytical water tools make life easier, water treatment simple and work more efficient.

Download the App at www.pyxis-lab.com/upyxis

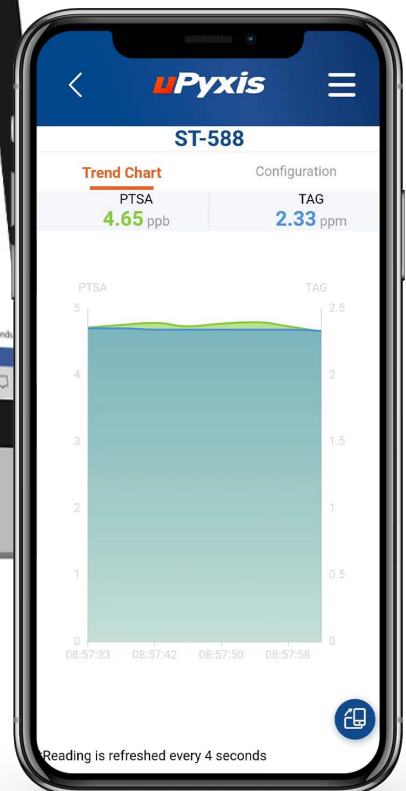

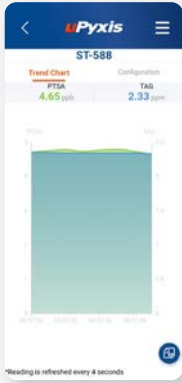

Wireless Monitoring & Calibration

Monitor your sensors with live reading displays right on your phone or computer. Get within range of your Pyxis Lab® device and quickly monitor the live readings. Live data charts and readings will display under the 'Reading' tab. Calibrate your device in minutes & make your life easy.

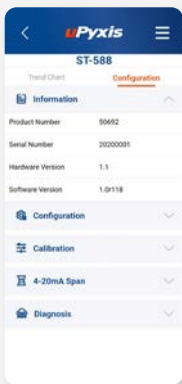

Configure Your Device to Fit Your System

Change internal settings like Device Name, Screen Shut-Off Time, Excitation Wavelengths, Product Factor & more to help match your specific application and ensure accurate readings.

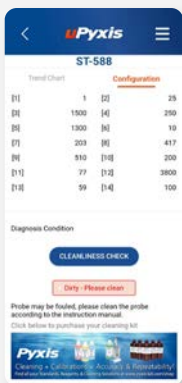

Wireless Sensor Diagnostics

Keep up on the quality of your inline sensors by running the Pyxis Lab® Cleanliness Check directly on your uPyxis® app. Simply select the 'Cleanliness Check' option and the app will immediately notify whether your sensor is 'Clean' or 'Dirty'.



Rapid Data Acquisition & Sharing

Quickly send your data findings over text, email or your favorite communication app. Save your data as a .CSV file to quickly create a spreadsheet of your data findings.

Introducing **CLOUD** DATA



All of your Accounts in One Place

Introducing a simple data management system that groups all of your accounts into an easy-to-navigate dashboard. From there, monitor live data trends of all your sensor technology operating via the CloudLink™ 4G LTE Gateway or the PowerCloud™ 4G Gateway & Power Supply Box.



CLOUD LINK

4G Gateway

An industrial 4G LTE Gateway that ties data into any Cloud-Based Software.

- ARM Cortex-A8 CPU
- Bluetooth® 5.0
- LTE Cat 4 Module
- Wi-Fi Connectivity, Support IEEE 802.11



POWER **CLOUD**

4G Gateway & Power

An industrial 4G LTE Gateway with external power supply. Allows users to power & remotely monitor several Pyxis Lab® devices. Contains the CloudLink™ & offers RS-485 Modbus and/or (8) 4-20mA inputs contained in a NEMA 4X enclosure box and a NEW touch screen display.

Learn More at www.pyxis-lab.com/cloud-data-management

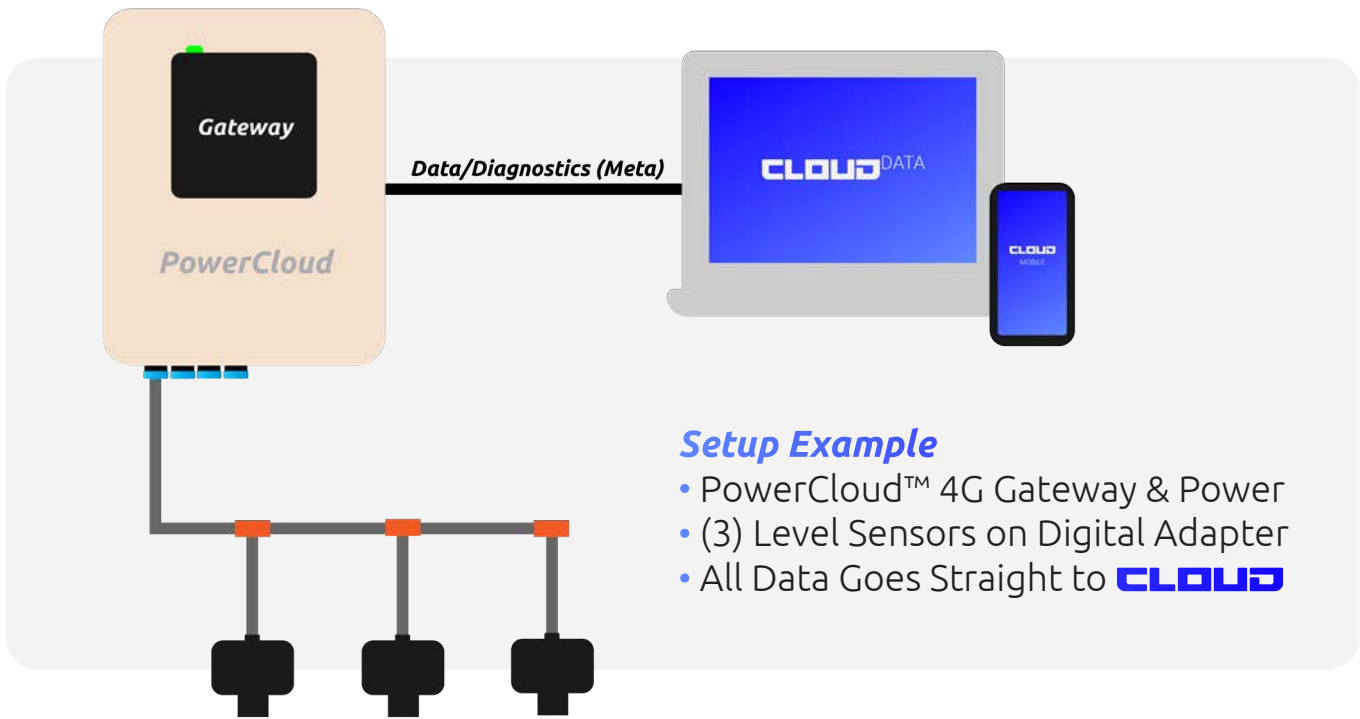

Setup Example

- PowerCloud™ 4G Gateway & Power
- (3) Level Sensors on Digital Adapter
- All Data Goes Straight to **CLOUD**





Water Professionals *Deserve Better Tools.*

Pyxis Lab, Inc.
21242 Spell Circle
Tomball, TX 77380
www.pyxis-lab.com