

Pyxis[®]

ST-72X Ultra-Low Conductivity Inline Sensors



Pyxis Lab[®] Inc.
1729 Majestic Dr. (Suite 5)
Lafayette, CO 80026
www.pyxis-lab.com

USER MANUAL

Table of Contents

1	Introduction	2
1.1	Features.....	2
2	Specifications	3
3	Unpacking Instrument	3
3.1	Standard Accessories.....	3
3.2	Optional Accessories.....	4
4	Installation	4
4.1	Piping.....	4
4.2	Wiring.....	7
4.3	Connecting via Bluetooth	7
5	Setup and Calibration with uPyxis® Mobile App	8
5.1	Download uPyxis® Mobile App.....	8
5.2	Connecting to uPyxis® Mobile App.....	9
5.3	Calibration Screen and Reading	10
5.4	Diagnosis Screen.....	11
5.5	Device Info Screen	12
6	Setup and Calibration with uPyxis® Desktop App	13
6.1	Install uPyxis® Desktop App.....	13
6.2	Connecting to uPyxis® Desktop App	14
6.3	Information Screen.....	15
6.4	Calibration Screen.....	15
6.5	Diagnosis Screen.....	16
7	Outputs	16
7.1	4–20mA Output Setup	16
7.2	Adjusting 4–20mA Span.....	17
7.3	Communication using Modbus RTU.....	17
8	Sensor Maintenance and Precaution	17
8.1	Methods to Cleaning the ST-725/728 Sensor.....	17
9	Troubleshooting	18
10	Contact Us	18

Warranty Information

Confidentiality

The information contained in this manual may be confidential and proprietary and is the property of Pyxis Lab, Inc. Information disclosed herein shall not be used to manufacture, construct, or otherwise reproduce the goods described. Information disclosed herein shall not be disclosed to others or made public in any manner without the express written consent of Pyxis Lab, Inc.

Standard Limited Warranty

Pyxis Lab warrants its products for defects in materials and workmanship. Pyxis Lab will, at its option, repair or replace instrument components that prove to be defective with new or remanufactured components (i.e., equivalent to new). The warranty set forth is exclusive and no other warranty, whether written or oral, is expressed or implied.

Warranty Term

The Pyxis warranty term is thirteen (13) months ex-works. In no event shall the standard limited warranty coverage extend beyond thirteen (13) months from original shipment date.

Warranty Service

Damaged or dysfunctional instruments may be returned to Pyxis for repair or replacement. In some instances, replacement instruments may be available for short duration loan or lease.

Pyxis warrants that any labor services provided shall conform to the reasonable standards of technical competency and performance effective at the time of delivery. All service interventions are to be reviewed and authorized as correct and complete at the completion of the service by a customer representative, or designate. Pyxis warrants these services for 30 days after the authorization and will correct any qualifying deficiency in labor provided that the labor service deficiency is exactly related to the originating event. No other remedy, other than the provision of labor services, may be applicable.

Repair components (parts and materials), but not consumables, provided during a repair, or purchased individually, are warranted for 90 days ex-works for materials and workmanship. In no event will the incorporation of a warranted repair component into an instrument extend the whole instrument's warranty beyond its original term.

Warranty Shipping

A Repair Authorization (RA) Number must be obtained from Pyxis Technical Support before any product can be returned to the factory. Pyxis will pay freight charges to ship replacement or repaired products to the customer. The customer shall pay freight charges for returning products to Pyxis. Any product returned to the factory without an RA number will be returned to the customer. To receive an RMA you can generate a request on our website at <https://pyxis-lab.com/request-tech-support/>.

Pyxis Technical Support

Contact Pyxis Technical Support at +1 (866) 203-8397, service@pyxis-lab.com, or by filling out a request for support at <https://pyxis-lab.com/request-tech-support/>.

1 Introduction

The Pyxis Lab ST-722, ST-724, ST-725 and ST-728 are industrial grade in-line ultra-low and standard range conductivity sensors specially designed for pure and ultra-pure water applications. They can be used for ultra-low conductivity measurement of pure water, ultra-pure water and deionized water including Boiler Feedwater and Condensate, RO and EDI/EDR process water, Ion Exchange, Distillation, Semi-Conductor Cleaning, Degas conductivity and other process applications. These are 'smart sensors' with a built-in transmitter supporting digital and analog signal outputs and are designed to simplify field installation, calibration and operation. The sensors offer simple ¾" MNPT threaded installation and are constructed with a Hastelloy electrode tip and stainless-steel body. The ST-724, ST-725 and ST-728 sensors can be wirelessly calibrated with uPyxis app for mobile or desktop devices when used with the MA-CR Bluetooth adapter. The sensors both offer two 4-20mA Analog outputs, one for conductivity and one for temperature, as well as RS-485 Modbus output for a broad array of installations that desire to connect the smart sensor directly to receiving controller, PLC or DCS network. Both sensors have built-in RTD for the automatic compensation of sample temperature.



1.1 Features

The ST-722, ST-724, ST-725 and ST-728 includes the following features:

- Easy installation into ¾" FNPT standard pipe Tee
- Optional Use with Pyxis Inline Tee Assemblies
- The latest short pulse type detection method technology
- Built-in temperature sensor with automatic compensation
- Front-end fully digital detection technology
- Accurate and stable measurement with ultra-low drift
- Built-in transmitter without preamplifier or meter head
- 2x 4–20mA isolated analog and RS-485 Modbus digital outputs
- Stainless-steel housing suitable for harsh environments
- Pollution-resistant and anti-interference design
- Unique electrode design greatly improves the long-term stability of the sensor in complex working environments and reduces the frequency of cleaning and maintenance
- ST-722 capable of measurement up to 10,000 µs/cm ideal for RO reject & concentrate
- Ultra-Low Detection 0.02 µs/cm (50 MΩ Resistivity) for ST-724/ST-725/ST-728

ST-722, ST-724, ST-725 and ST-728
Ultra-Low Conductivity Sensors

2 Specifications

Table 1. ST-722/ST-724/ST-725/ST-728 Specifications

Item	ST-724	ST-725	ST-728	ST-722
P/N	10009	53108	53117	53103
Conductivity Range $\mu\text{S}/\text{cm}$	0.00 - 1,000.0	0.00 - 200.0	0.00 - 10.00	0.0 – 10,000
Conductivity Precision	$\pm 0.2 \mu\text{S}/\text{cm}$ or $\pm 1\%$ (<500 μS) $\pm 2\%$ (>500 μS)	$\pm 0.1 \mu\text{S}/\text{cm}$ or 1% of value		$\pm 10 \mu\text{S}/\text{cm}$ or 2% of value
4-20mA Range for Temp	32 - 212 °F (0 - 100 °C)			
Temperature Precision	$\pm 1\%$ of the value			
Cell Constant (K)	0.3			
Response	T90 = 92 Sec.			
Sample Pressure	Up to 100 psi (0.7 MPa)			
Power Supply	22 – 26V DC, Power Consumption 2W			
Dimension (L x W x H)	Length 8.46 inch (215 mm), body diameter 1.32 Inch (33.6 mm)			
Installation	$\frac{3}{4}$ " NPT or Pyxis ST-001 or ST-007 Inline Tee Assemblies			
Body Material	304 stainless steel			
Weight	530 g (1.10 lbs)			
Operational Pressure	100 psi (6.9 Bar)			
Operating Temperature	40 - 120 °F (4 - 49 °C)			
Storage Temperature	20 - 140 °F (-7 - 60 °C)			
Outputs	8Pin - Isolated Dual 4 – 20 mA Analog Output & Isolated RS-485 Digital Output			
Wet Material	HASTELLOY			
Rating	IP67, Fully Dustproof & Waterproof			
Regulation	CE, UKCA, RoHS Marked			
Cable Length	5 ft (1.5 m) [§] - (Extension Cables Available)			

* With Pyxis's continuous improvement policy, these specifications are subject to change without notice.

3 Unpacking Instrument

Remove the instrument and find the standard accessories from the shipping container as listed below. Inspect each item for any damage that may have occurred during shipping. Verify that all accessory items are included. If any item is missing or damaged, please contact Pyxis Lab Customer Service at service@pyxis-lab.com.

3.1 Standard Accessories

- One ST-722 (P/N – 53103) or One ST-724 (P/N – 10009) or One **ST-725** (P/N – 53108) or **ST-728** (P/N – 53117) sensor
- One **MA-1.49CR Cable** (1.5 m/4.9 ft 8-Pin Male Adapter/Female Adapter)
- One **MA-1.5CR Cable** (1.5 m/4.9 ft 8-Pin Male Adapter/Flying Lead)
- User Manual is also available for download at <https://pyxis-lab.com/support/>

3.2 Optional Accessories

The following optional accessories can be purchased via your Regional Sales contact or Pyxis Customer Service at order@pyxis-lab.com.

Table 2. Optional Accessories

Optional Accessory	Part Number (P/N)
MA-CR <i>(Bluetooth / USB Adapter For uPyxis use with ST-724 / ST-725/ ST-728)</i>	MA-CR
MA-NEB <i>(Bluetooth-USB Adapter for Desktop use with uPyxis)</i>	MA-NEB
ST-001 <i>(CPVC Inline Tee Assembly Sold Separately)</i>	50704
ST-007 <i>(316L Stainless Steel Inline Tee Assembly Sold Separately)</i>	50700-A51
MA-50CR (50' Extension Cable w/8Pin Adapters)	50743
MA-100CR (100' Extension Cable w/8Pin Adapters)	50744
Pyxis ST-Series Sensor Cleaning Kit	SER-01
POWERPack — 1 <i>(Bluetooth Adapter with Power Supply for 1x Pyxis Sensor)</i>	MA-BLE-1

4 Installation

The dimensional drawings of the ST-722, ST-724, ST-725 and ST-728 are as follows.

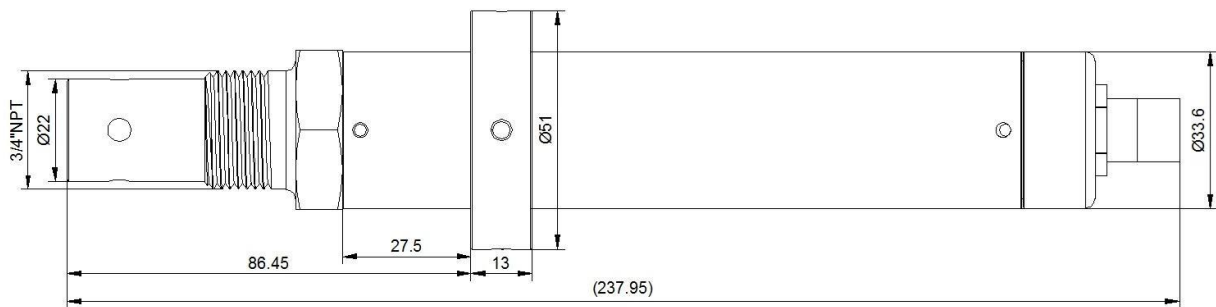

Figure 1. Dimension of the ST-722, ST-724, ST-725 and ST-728 (mm)

4.1 Piping

Proper Installation Methods:

- Water flowing from the bottom up in the pipe keeps the conductivity cell full of water and prevents air bubbles and air buildup while ensuring accurate measurement. As shown in Figure 2.
- The conductivity cell is located at the bottom of the water stream and is less likely to accumulate air. However, it is worth noting that this type of installation should prevent the conductivity cell from reaching in too short and forming a dead zone. As shown in 3.
- The conductivity cell is located on the side of the pipe, which avoids the accumulation of air to a greater extent and is less susceptible to contaminant deposits and ensures accurate measurements. As shown in 4.

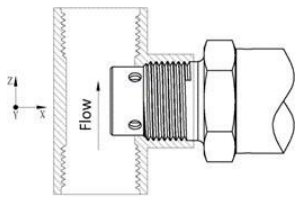

Figure 2. Installation Method

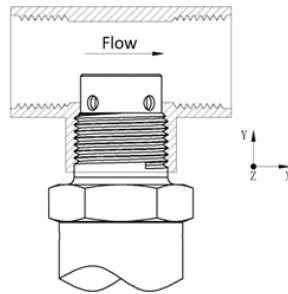

Figure 3. Installation Method

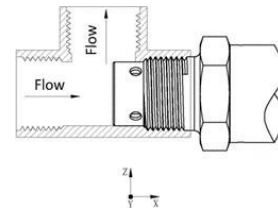

Figure 4. Installation Method

Improper Installation Methods:

The following 3 installation methods should be avoided. These installation methods can easily produce air bubbles and air accumulation leading to unstable measurement. As shown in Figure 5.

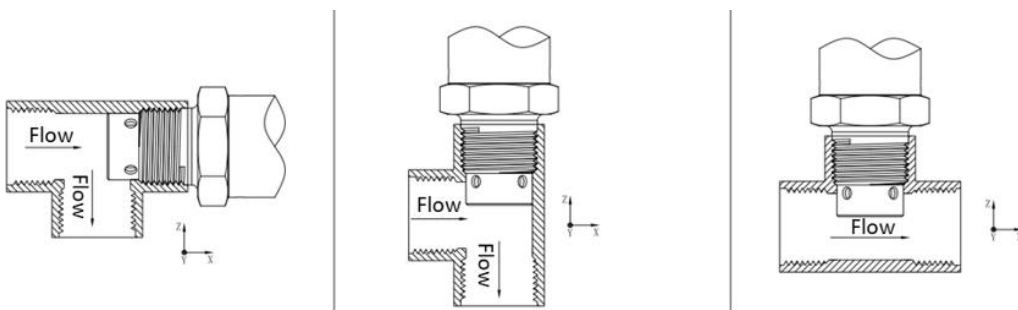

Figure 5. Installation methods to be avoided.

Installation Using Pyxis Tee Assemblies and Collar

The ST-722, ST-724, ST-725 and ST-728 offers a sensor collar which enables installation into a Pyxis inline tee assembly. Both the ST-001 (CPVC) and ST-007 (316L Stainless) inline Tee assemblies may be used for installation format. Pyxis inline tee assemblies are sold separately.

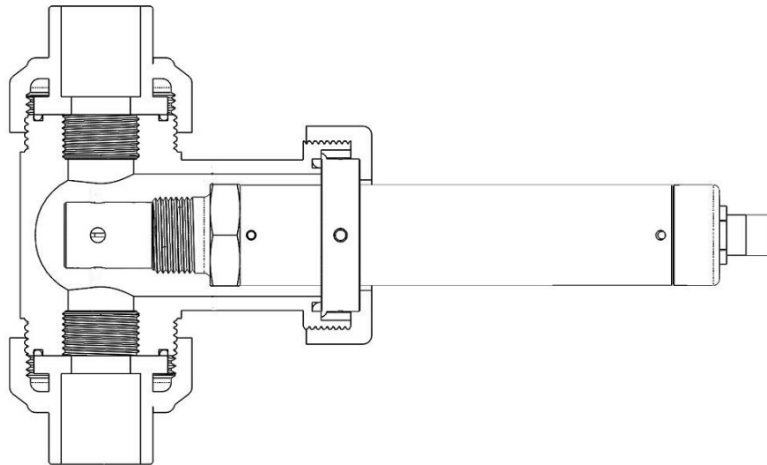

Figure 5A. Installation in ST-001 (CPVC) Inline Tee Assembly

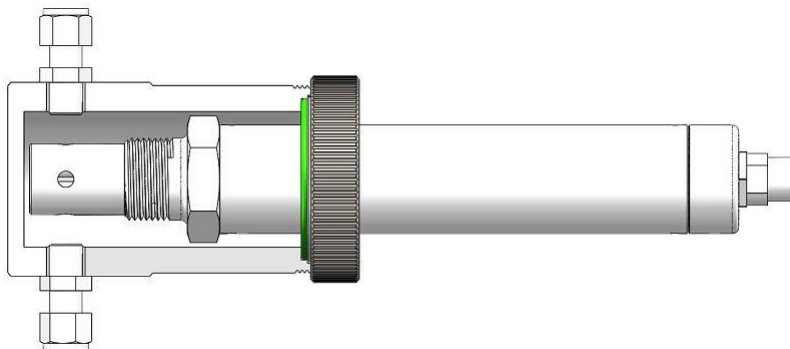

Figure 5B. Installation in ST-007 (316L Stainless) Inline Tee Assembly

4.2 Wiring

If the power ground terminal and the negative 4–20mA terminal in the controller are internally connected (non-isolated 4–20mA input), it is unnecessary to connect the 4–20mA negative wire (Gray) to the 4–20mA negative terminal in the controller. If a separate DC power supply other than that from the controller is used, make sure that the output from the power supply is rated for 22–26 VDC @ 65mA.

NOTE *The negative 24V power terminal (power ground) and the negative 4–20mA terminal on the ST-722/ST-724/ST-725/728 sensor are internally connected.*

Follow the wiring table below to connect the ST-722, ST-724, ST-725 and ST-728 sensor to a controller:

Table 3.

Wire Color	Designation
Red	24V +
Brown	24V Power ground
White	Conductivity, 4–20mA +
Pink	Temperature, 4–20mA +
Gray*	4–20mA -
Blue	RS-485 A
Yellow	RS-485 B
Green	RS-485 C
Black	Shield, earth ground

* Internally connected to the power ground

4.3 Connecting via Bluetooth

A Bluetooth adapter (P/N: MA-CR) can be used to connect the ST-722, ST-724, ST-725 and ST-728 sensor to a smart phone with the **uPyxis®** Mobile App or a computer with the **uPyxis®** Desktop App. The power should be sourced from a 24 VDC power terminal of a controller. If a controller is not available, the user may also use Pyxis PowerPACK-1 or PowerPACK-4 as an alternative to both an external power supply and a Bluetooth adapter. PowerPACK from Pyxis Lab offers external power, Input/Output signal, and Bluetooth connectivity.

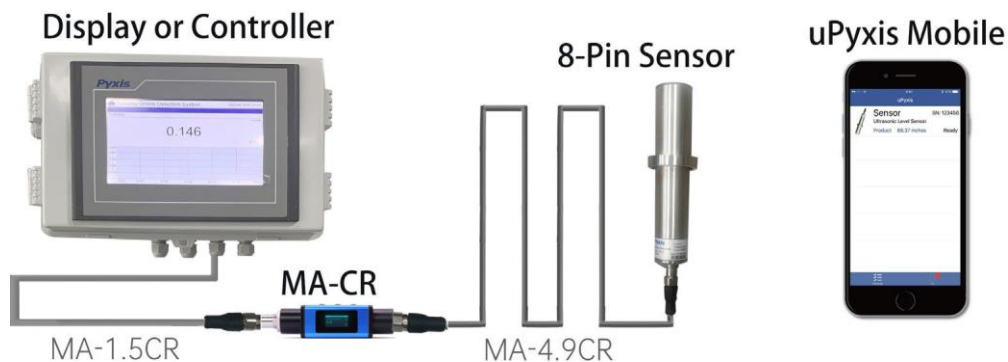

Figure 6. Bluetooth connection to ST-72X sensor series with MA-CR and uPyxis Mobile App.

5 Setup and Calibration with uPyxis® Mobile App

The ST-722, ST-724, ST-725 and ST-728 ultra-low conductivity sensors are rigorously calibrated before leaving the factory. As such, users do not need to calibrate the probe for a period of one year if the sensor is maintained clean. Users can however calibrate the probe according to their needs and as desired using the MA-CR Bluetooth adapter and uPyxis APP for mobile or desktop devices.

The ST-722, ST-724, ST-725 and ST-728 sensors require a slope calibration for conductivity. The conductivity can be calibrated with a standard containing 0.02 $\mu\text{S/cm}$ to 10,000 $\mu\text{S/cm}$ conductivity (depending on the sensor selected) or with the sample water itself. The conductivity concentration of the sample water can be measured using the Pyxis SP-600 Portable Water Multimeter (P/N – 50353). Before calibration, the sensor should be cleaned with deionized water.

NOTE Please take special care to avoid direct contact of the sensor electrode with the hand or fingers.

5.1 Download uPyxis® Mobile App

Download uPyxis® Mobile App from [Apple App Store](#) or [Google Play](#).



Figure 7. uPyxis® Mobile App installation

5.2 Connecting to uPyxis® Mobile App

Connect the ST-722/ST-724/ST-725/728 sensor to a mobile smart phone according to the following steps:

1. Open **uPyxis®** Mobile App.
2. On **uPyxis®** Mobile App, pull down to refresh the list of available Pyxis devices.
3. If the connection is successful, the ST-722, ST-724, ST-725 and ST-728 and its Serial Number (SN) will be displayed (Figure 8).
4. Press on the **ST-722/ST-724/ST-725/ST-728 sensor image**.

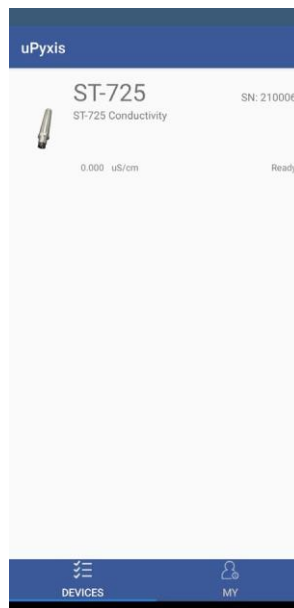

Figure 8.

5.3 Calibration Screen and Reading

When connected, the uPyxis® Mobile App will default to the **Calibration** screen. From the **Calibration** screen, you can perform calibrations by pressing on **Slope Calibration** and **4-20mA Span**. Follow the screen instructions for each calibration step.

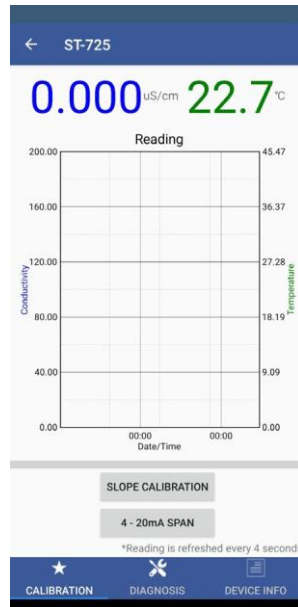

Figure 9.

The default 4-20mA configuration for all sensors are listed below.

Sensor Name	Conductivity		Temperature	
	4mA	20mA μ S/cm	4mA	20mA
ST-722	0 μ S/cm	10,000 μ S/cm	32°F / 0°C	212°F / 100°C
ST-724	0 μ S/cm	1,000 μ S/cm	32°F / 0°C	212°F / 100°C
ST-725	0 μ S/cm	200 μ S/cm	32°F / 0°C	212°F / 100°C
ST-728	0 μ S/cm	10 μ S/cm	32°F / 0°C	212°F / 100°C

5.4 Diagnosis Screen

From the **Diagnosis** screen, you can check the diagnosis condition. This feature may be used for technical support when communicating with service@pyxis-lab.com.

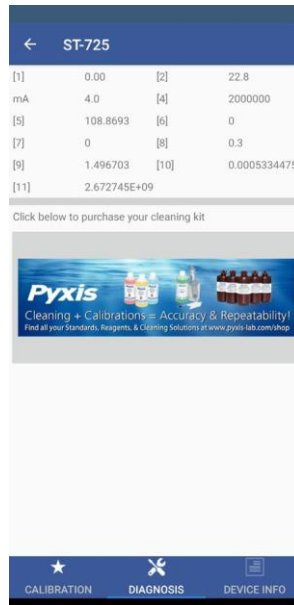

Figure 10.

5.5 Device Info Screen

From the **Device Info** screen you can name the Device or Product and set the **Modbus Address**

The screenshot shows a mobile application interface for configuring a device. At the top, there is a blue header with a back arrow and the device ID 'ST-725'. Below this, there are two sections for naming the device. The first section is labeled 'Device Name' and contains a text input field with the placeholder 'Set a nickname for the device'. The second section is labeled 'Product Name' and contains a text input field with the placeholder 'The name of the product that the device is measuring'. Below these sections is a grey button labeled 'APPLY SETTINGS'. Underneath the button is a 'Modbus' section with a 'Modbus Address' field containing the value '14' and a note that says 'Tap the Modbus address to change it'. At the bottom of the screen is a dark blue navigation bar with three icons and labels: a star for 'CALIBRATION', a wrench for 'DIAGNOSIS', and a document for 'DEVICE INFO'.

Figure 11.

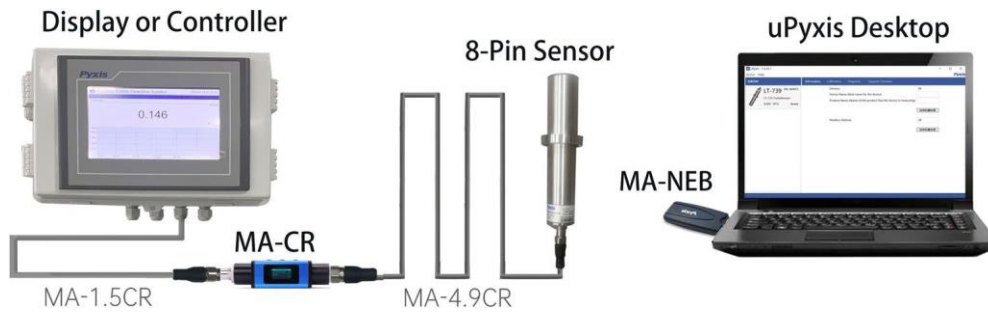

Figure 12. Bluetooth connection to ST-72X Sensor with MA-CR, MA-NEB and uPyxis Desktop.

6 Setup and Calibration with uPyxis® Desktop App

The ST-722, ST-724, ST-725 and ST-728 ultra-low conductivity sensors are rigorously calibrated before leaving the factory. As such, users do not need to calibrate the probe for a period of one year if the sensor is maintained clean. Users can however calibrate the probe according to their needs and as desired using the MA-CR Bluetooth adapter and uPyxis APP for mobile or desktop devices.

The ST-722, ST-724, ST-725 and ST-728 sensors require a slope calibration for conductivity. The conductivity can be calibrated with a standard containing 0.02 $\mu\text{S}/\text{cm}$ to 10,000 $\mu\text{S}/\text{cm}$ conductivity (depending on the sensor selected) or with the sample water itself. The conductivity concentration of the sample water can be measured using the Pyxis SP-600 Portable Water Multimeter (P/N – 50353). Before calibration, the sensor should be cleaned with deionized water.

NOTE Please take special care to avoid direct contact of the sensor electrode with the hand or fingers.

6.1 Install uPyxis® Desktop App

Download the latest version of uPyxis® Desktop software package from: <https://pyxis-lab.com/upyxis/> this setup package will download and install the Microsoft.Net Framework 4.5 (if not previously installed on the PC), the USB driver for the USB-Bluetooth adapter (MA-NEB), the USB-RS485 adapter (MA-485), and the main uPyxis® Desktop application. Double click the **uPyxis.Setup.exe** file to install.

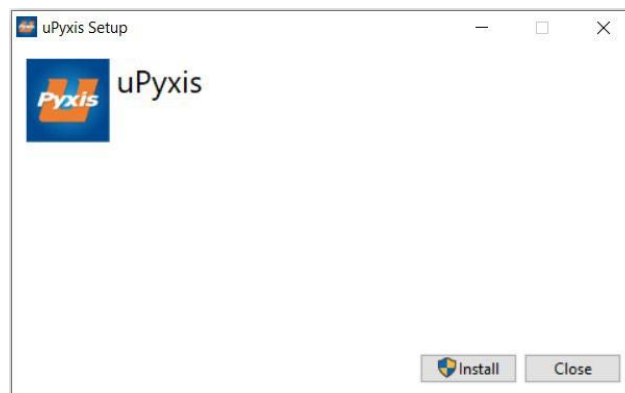

Figure 13. uPyxis® Desktop App installation

Click **Install** to start the installation process. Follow the screen instructions to complete the USB driver and uPyxis® installation.

6.2 Connecting to uPyxis® Desktop App

Connect the ST-722/ST-724/ST-725/ST-728 sensor to a Windows computer using a Bluetooth/USB adapter (P/N: MA-NEB) according to the following steps:

1. Plug the Bluetooth/USB adapter into a USB port in the computer.
2. Launch **uPyxis®** Desktop App.
3. On **uPyxis®** Desktop App, click Device→ **Connect via USB-Bluetooth** (Figure 13).
4. If the connection is successful, the ST-722/ST-724/ST-725/728 and its Serial Number (SN) will be displayed in the left pane of the **uPyxis®** window.

NOTE After the sensor and Bluetooth is powered up, it may take up to 10 seconds for the adapter to establish the wireless signal for communication.

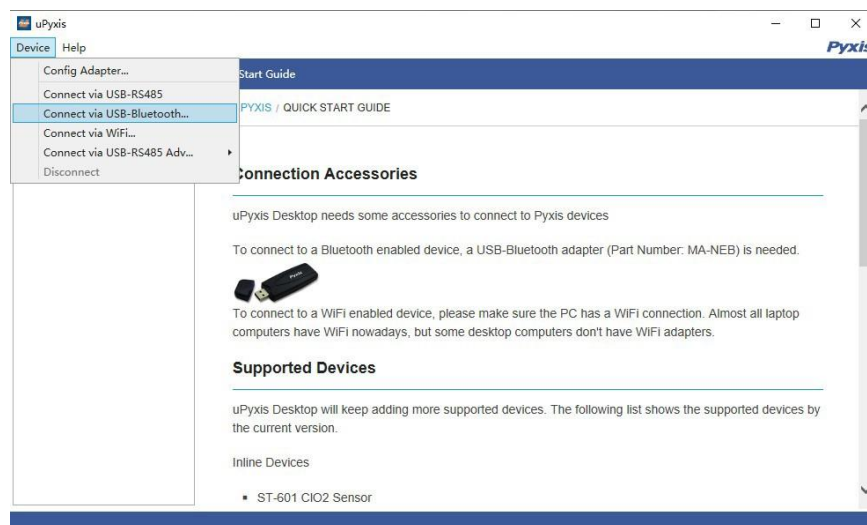

Figure 14.

6.3 Information Screen

Once connected to the device, a picture of the device will appear on the top-left corner of the window and the uPyxis® Desktop App will default to the **Information** screen. On the **Information** screen you can set the information description for **Device Name**, **Product Name**, and **Modbus Address**, then click **Apply Settings** to save.

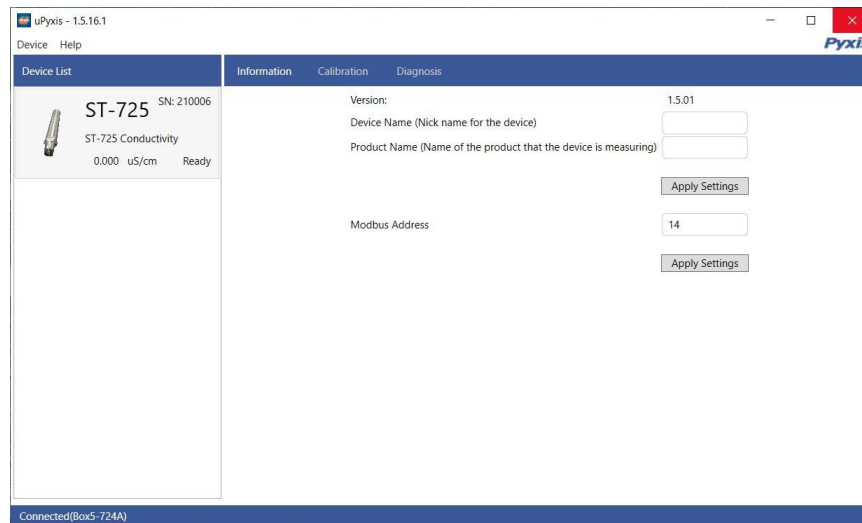

Figure 15.

6.4 Calibration Screen

To calibrate the device, click on **Calibration**. On the **Calibration** screen there are two calibration buttons, **Slope Calibration** and **4-20mA Span**. The screen also displays the reading of the device. The reading refresh rate is every 4 seconds. Follow the screen instructions for each calibration step.

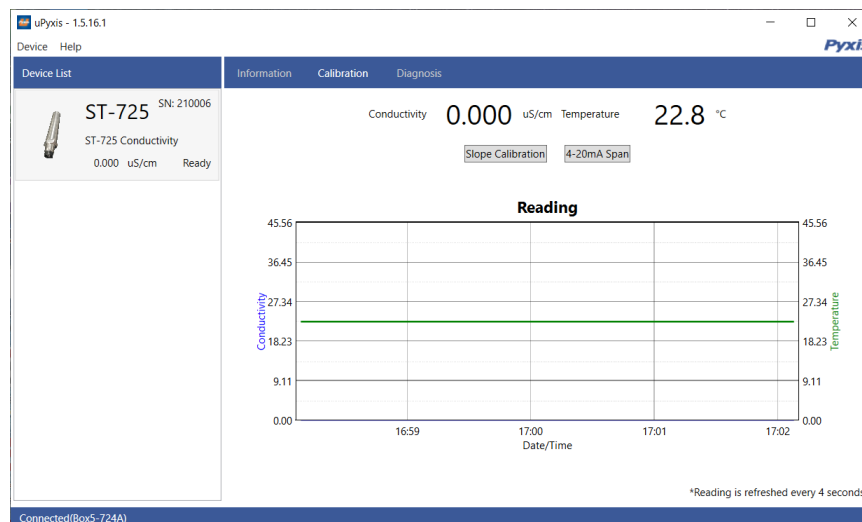

Figure 16.

6.5 Diagnosis Screen

After the device has been calibrated and installation has been completed, to check diagnosis, click on **Diagnosis**. When in the **Diagnosis** screen you can view the Diagnosis Condition of the device. This feature may be used for technical support when communicating with service@pyxis-lab.com.

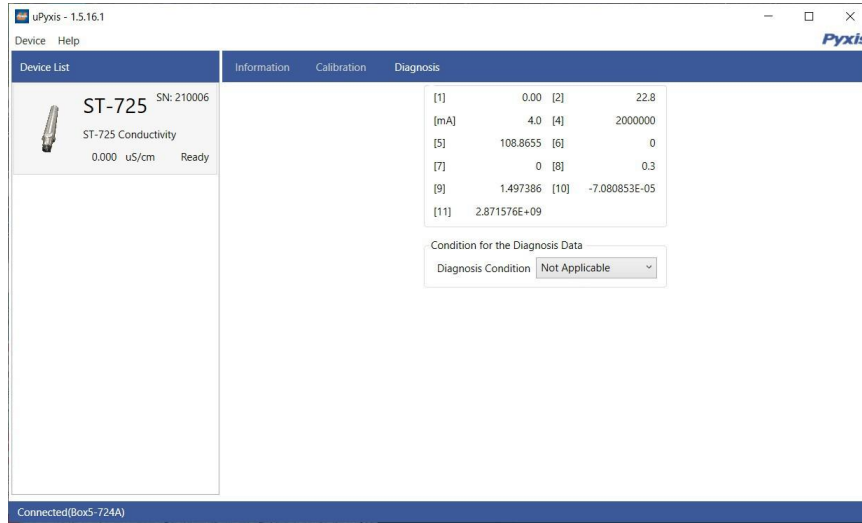

Figure 17.

7 Outputs

7.1 4–20mA Output Setup

Please refer to the table below for default 4-20mA configuration.

Sensor Name	Conductivity		Temperature	
	4mA	20mA	4mA	20mA
ST-722	0 μS/cm	10,000 μS/cm	32°F / 0°C	212°F / 100°C
ST-724	0 μS/cm	1,000 μS/cm	32°F / 0°C	212°F / 100°C
ST-725	0 μS/cm	200 μS/cm	32°F / 0°C	212°F / 100°C
ST-728	0 μS/cm	10 μS/cm	32°F / 0°C	212°F / 100°C

7.2 Adjusting the 4-20mA Span

Users may adjust the output scale using 4–20mA Span to change the conductivity value corresponding to the 20 mA output via uPyxis®. For the uPyxis® Mobile App, press **4-20mA Span** found on the **Calibration Screen and reading**, shown in Figure 18. For the uPyxis® Desktop App, click **4-2mA Span** found on the **Calibration Screen**, shown in Figure 19. ***NOTE* the 20mA can only be configured to a value BELOW the maximum upper level of detection of the sensor, not above.**

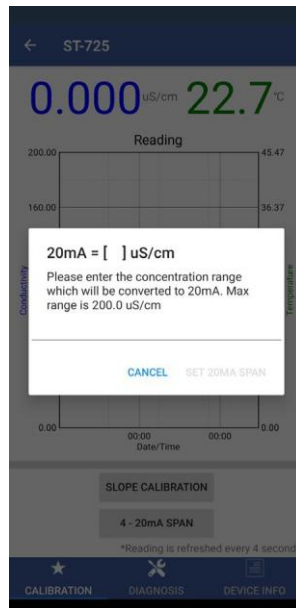

Figure 18.

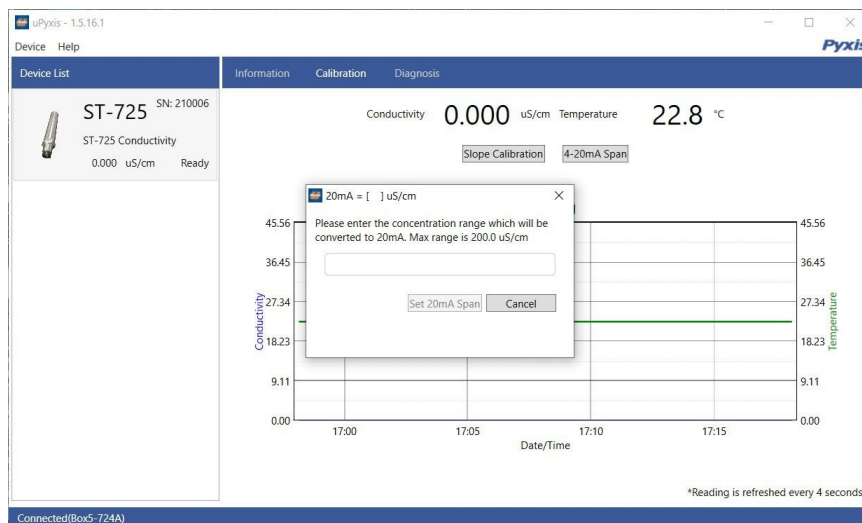

Figure 19.

7.3 Communication using Modbus RTU

The ST-722/ST-724/ST-725/ST-728 sensor are configured as a Modbus slave device. In addition to the $\mu\text{S}/\text{cm}$ conductivity value, many operational parameters, including warning and error messages, are available via a Modbus RTU connection. Contact Pyxis Lab Customer Service (service@pyxis-lab.com) for more information.

8 Sensor Maintenance and Precaution

8.1 Methods to Cleaning the ST-722/ST-724/ST-725/728 Sensors

The ST-722/ST-724/ST-725/728 sensor is designed to provide stable conductivity measurements in pure water, so in general, the sensor is less likely to become contaminated. If scaling occurs, particularly iron oxide deposits, they can be removed using a cleaning solution capable of removing iron, such as the Pyxis Lab **Inline Probe Cleaning Solution Kit** (P/N: SER-01) which can be purchased at our online E-Store <https://pyxis-lab.com/product/st-series-probe-cleaning-kit/>



Figure 20. Inline Probe Cleaning Solution Kit

To clean the ST-722/ST-724/ST-725/ST-728 sensor, soak the lower half of the sensor in 100 ml of in-line sensor cleaning solution for 10 minutes or longer (the cleaning solution should completely submerge the front electrode). After soaking, gently scrub the electrode surface with a cotton swab. The cleaned sensor should be thoroughly cleaned with DI water and calibrated before use.

9 Troubleshooting

If the ST-722/ST-724/ST-725/ST-728 sensor output signal is not stable and fluctuates significantly, make an additional ground connection — connect the black (shield, earth ground) wire to a conductor that contacts the sample water electrically such as a metal pipe adjacent to sensor tee.

10 Contact Us

Pyxis Lab, Inc

21242 Spell Circle

Tomball TX 77375

www.pyxis-lab.com

Phone: +1 (866) 203-8397

Email: service@pyxis-lab.com